

STATE OF LIBYA
MINISTRY OF TRANSPORT
CIVIL AVIATION AUTHORITY



دولة ليبيا
وزارة المواصلات
مصلحة الطيران المدني

<p>Contacts info@caa.gov.ly std@caa.gov.ly fsd@caa.gov.ly Tele / fax +218 21 3605318 /22+218 21 3605318</p>	<p>Advisory Circular (AC) LYCAA-AC-OPS.H 001</p>	<p>Issued on 16/01/2018 Revision: Initial</p>
--	---	---

Advisory Circular-LYCAA/AC-OPS.H 001

Standards for offshore helicopter landing areas

Approved by



161-18

Capt / Nasereddin Shaebelain
Director General

Published by Libyan Civil Aviation Authority (LYCAA)

1. PURPOSE

This For the purpose of providing the operators with a single document contains acceptable means of compliance , guidance material and information on Libyan off-shore installations to accountable Organisations (Responsible for the safety oversight of helideck operating companies), and to helideck Operators to meet the offshore operations requirements, the LYCAA has adopted the Guidance Material contained in the (**UK CAA CAP 437 (Standards for offshore helicopter landing areas)**) This Advisory Circular is issued to reflect this policy and to ensure unified approach for the development and implementation of the CAP 437.

The Libyan Civil Aviation Authority (LYCAA) Requirements for Air Operators, Operational Requirements AIR-OPS, Part SPA (Subpart K-HOFO), are reflected in CAP 437 Appendix material e.g. Appendix A is substantially based on GM2 SPA.HOFO.115 Use of offshore locations

2. Operational Regulations (Helicopters):

Provides regulation specifically for helicopter operations Helideck operators should make reference to this document as an appreciation of the helicopter Operators' responsibilities as holder of an air operator certificate (AOC). Such operators shall ensure that all pilots are familiar with the regulations and procedures pertinent to the performance of their duties.

3. Flight Safety Department (Operations section):

Flight Operations Managers shall assess the application of the operations for which the facility is designed, in relation to LYCARs-AIR OPS (H). This will include the direction of flight; the assessment of the obstacle environment on the basis of the intended use of a FATO; the acceptance of the Declared Distances and obstacle limitation surfaces in relation to the most critical helicopter type for which the helideck is intended.

One of the longer term intentions of this AC was to improve safety on helidecks.

4. REFERENCES:

4.1. The LYCARs Part SPA (Subpart K), Part NCC, and Part SPO.

4.2. ICAO ANNEX 6 Part III.

4.3. UK CAA CAP 437 (**Copy attached and downloadable from:**

<http://publicapps.caa.co.uk/modalapplication.aspx?appid=11&mode=detail&id=523>)

5. Applicability

This Advisory Circular is applicable to all Air Operators, and shall be effective from **15 February 2018**.

-----End-----

Standards for offshore helicopter landing areas

CAP 437

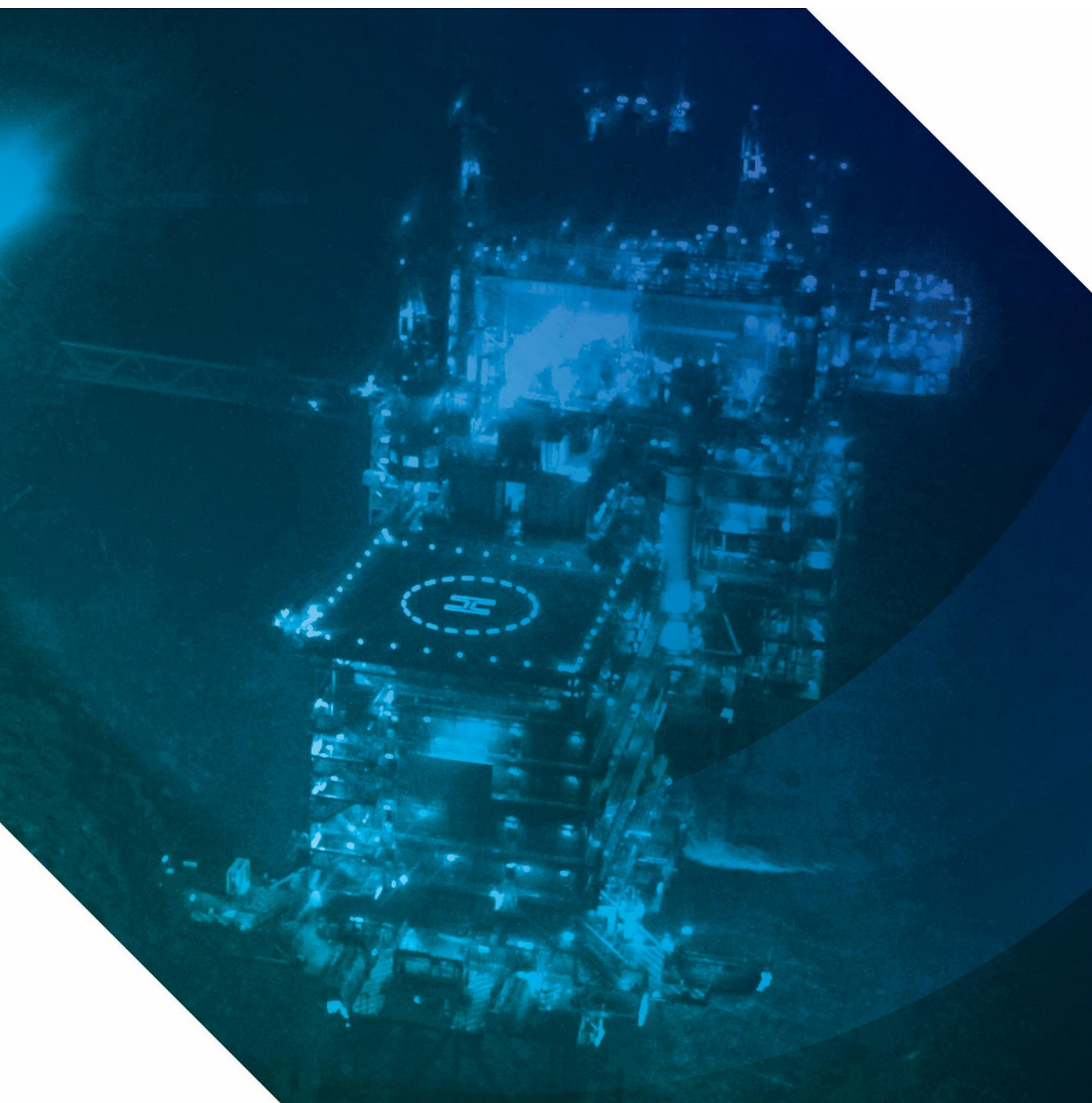

Published by the Civil Aviation Authority, 2016

Civil Aviation Authority,
Aviation House,
Gatwick Airport South,
West Sussex,
RH6 0YR.

You can copy and use this text but please ensure you always use the most up to date version and use it in context so as not to be misleading, and credit the CAA.

ISBN 9780 11792 914 2

First published 1981

Second edition December 1993

Third edition October 1998

Fourth edition September 2002

Fifth edition August 2005

Sixth edition December 2008

Amendment 01/2010 April 2010

Amendment 02/2010 August 2010

Edition 7 May 2012

Amendment 01/2013 February 2013

Edition 8 December 2016

Enquiries regarding the content of this publication should be addressed to: ISPTechnicalSupportTeam@caa.co.uk

Intelligence, Strategy & Policy, Safety & Airspace Regulation Group, Civil Aviation Authority, Aviation House, Gatwick Airport South, West Sussex, RH6 0YR

The latest version of this document is available in electronic format at www.caa.co.uk, where you may also register for e-mail notification of amendments.

Contents

Contents	1
Revision history.....	9
Foreword.....	13
Glossary of terms and abbreviations	20
Chapter 1	25
Introduction	25
History of development of criteria for offshore helicopter landing areas, 1964-1973	25
Department of Energy and the Health and Safety Executive guidance on the design and construction of offshore installations, 1973 onwards.....	25
Applicability of standards in other cases	30
Worldwide application	30
Chapter 2	32
Helicopter performance considerations	32
General considerations.....	32
Safety philosophy	32
Factors affecting performance capability	33
Chapter 3	34
Helicopter landing areas – Physical characteristics	34
General	34
Helideck design considerations – Environmental effects	35
Introduction	35
Helideck design guidance	37
Design criteria.....	37
Structural design.....	41
Loads.....	43
Size and obstacle protected surfaces.....	46

Temporary combined operations	52
Multiple platform configurations/location of standby vessels	54
Surface	55
Helicopter tie-down points.....	60
Perimeter safety net.....	61
Access points.....	62
Winching (hoist) operations.....	64
Normally Unattended Installations (NUIs)	64
Criteria for parking areas.....	65
Chapter 4	68
Visual aids	68
General	68
Helideck landing area markings.....	70
Lighting.....	79
Perimeter lighting	80
Floodlighting, lit TD/PM circle and lit heliport identification 'H' marking.....	81
Helideck status light system	83
UPS requirement	86
Obstacles – Marking and lighting.....	86
Chapter 5	89
Helideck rescue and fire fighting facilities.....	89
Introduction	89
Key design characteristics – Principal agent.....	89
Use and maintenance of foam equipment	94
Complementary media.....	95
Normally unattended installations	96
The management of extinguishing media stocks	98
Rescue equipment.....	98
Personnel levels	100

Personal Protective Equipment (PPE)	100
Training	101
Emergency procedures	101
Further advice	101
Chapter 6	102
Miscellaneous operational standards	102
Landing area height above water level	102
Wind direction (vessels)	102
Helideck movement	102
Helideck motion reporting	105
Meteorological information.....	106
Meteorological observations	106
Assessment of wind speed and direction	107
Reporting of meteorological information.....	107
Pre-flight weather reports.....	107
Radio messages	108
Collection and retention of meteorological information	108
Real-time web-based systems	109
Meteorological observer training	109
Calibration of meteorological equipment sensors.....	109
Location in respect to other landing areas in the vicinity	110
Control of crane movement in the vicinity of landing areas	111
General precautions	111
Installation/Vessel helideck operations manual and general requirements	112
Helicopter operations support equipment	112
Chapter 7	114
Helicopter fuelling facilities – Systems design and construction	114
General	114
Product identification	115

Fuelling system description.....	115
Design considerations	116
Static storage tanks	117
Sample reclaim tank	120
Delivery system	121
Transfer system	133
Transit tanks	134
Chapter 8	138
Helicopter fuelling facilities – Maintenance and fuelling procedures	138
Fuel quality sampling and sample retention	139
Fuel sample containers	139
Fuel sampling	140
Fuel sample retention	144
Decanting from sample reclaim tanks	145
Recommended maintenance schedules	146
Transit tanks	146
Static storage tanks	149
Delivery systems.....	151
Miscellaneous inspection frequency.....	163
System breakdown	164
Sample reclaim tanks	165
Transit tanks.....	166
Filling of transit tanks	166
Receipt of transit tanks offshore.....	167
Decanting from transit tanks to static storage.....	168
Set-up for fuelling direct from transit tanks	169
Set-up for fuelling from static storage tanks	170
Static storage tank draining.....	171
Long term storage of aviation fuel.....	173

Aircraft refuelling	173
Quality control documentation	176
Chapter 9	178
Helicopter landing areas on vessels.....	178
Vessels supporting offshore mineral workings and specific standards for landing areas on merchant vessels.....	178
Amidships helicopter landing areas – Purpose-built or non-purpose-built ship’s centreline.....	179
Size and obstacle environment	179
Helicopter landing area marking and lighting.....	182
Ship’s side non-purpose-built landing area	184
Ship’s side non-purpose-built landing area markings	186
Night operations	188
Poop deck operations.....	188
Chapter 10	189
Helicopter winching areas on vessels and on wind turbine platforms	189
Winching areas on vessels	189
Design and obstacle restriction	189
Visual aids	190
Obstructions.....	192
Hoisting above accommodation spaces	192
Helicopter winching areas on wind turbine platforms	192
Platform design.....	193
Obstacle restriction	196
Visual aids	196
Further operational conditions	200
Appendix A.....	201
Use of offshore locations.....	201
AMC1 SPA.HOFO.115	201
General.....	201

GM1 SPA.HOFO.115	207
Appendix B	209
Bibliography	209
References	209
Health and Safety Executive	209
International Civil Aviation Organization	210
Other publications	210
Civil Aviation Authority – CAPs, research papers and policy statements	211
Sources	213
Appendix C	215
Specification for helideck lighting scheme comprising perimeter lights, lit touchdown/positioning marking and lit heliport identification marking	215
Overall operational requirement	215
Definitions	217
The perimeter light requirement	218
The touchdown/positioning marking circle requirement	219
The heliport identification marking requirement	223
General characteristics	226
Requirements	226
Other considerations	227
Appendix D	229
Helideck fire fighting provisions for existing NUI assets on the UK continental shelf	229
Appendix D1	229
Introduction	229
Definitions	232
H1/H2 scheme details	232
Appendix D2	235
Letter to industry July 2011	235
Appendix E	258

Additional guidance relating to the provision of meteorological information from offshore installations	258
Introduction	258
Contents and standardisation of the weather reports issued by each offshore installation	258
Wind	258
Visibility.....	259
Lightning	259
Present weather.....	259
Cloud	261
Air temperature and dew point	261
QNH and QFE (atmospheric pressure)	261
Significant wave height	261
Pitch, roll, helideck inclination and significant heave rate	262
Remarks	262
Missing or unavailable information	262
Example offshore report	262
Definition of an offshore meteorological observer	265
Applicability of meteorological equipment to helideck categories	265
Design, siting and back-up requirements for meteorological equipment installed in offshore installations.....	266
Wind speed and direction.....	266
Temperature	268
Pressure	269
Visibility.....	271
Present weather sensor	273
Cloud	274
Calibration, maintenance and servicing periods	276
Appendix F	277

Procedure for authorising offshore helicopter landing areas – letter to offshore helicopter operators, October 2011	277
Appendix G.....	279
Guidance for helideck floodlighting systems.....	279
Introduction	279
General considerations for helideck floodlighting.....	279
Improved floodlighting system	281
Appendix H.....	283
Risk assessment for helicopter operations to helidecks in the UKCS which are sub-1D....	283
Appendix I	291
CAA protocol for operations against operating status lights or black decks	291
Appendix J	296
Specification for a helicopter hoist status light.....	296
Application.....	296
Operational requirements	296
Location	296
Performance	297
Day/Night operation	297
Characteristics.....	298
Appendix K.....	301
Helideck friction survey protocol.....	301
Introduction	301
Friction measuring equipment	301
Survey procedure	302
General.....	302
Preparation	302
Survey	302
Presentation of results.....	303

Revision history

Edition 1**September 1981**

The first edition of CAP 437 was published to give guidance on the criteria applied by the CAA in assessing the standard of helicopter offshore landing areas for worldwide use by helicopters registered in the UK. The criteria in the CAP relating to fixed and mobile installations in the area of the UK Continental Shelf were based on the helicopter landing area standards of the Department of Energy. Additional criteria were given relating to vessels used in the support of offshore mineral exploitation and tankers, cargo vessels and passenger vessels which were not subject to the Department of Energy certification. These criteria were evolved following consultation with the Department of Trade (Marine Division) and the Inter-governmental Maritime Consultative Organisation. In addition to explaining the reasons behind the chosen criteria, the first edition of CAP 437 described their application to particular classes of landing area.

Edition 2**December 1993**

The guidance in CAP 437 was revised in the light of International Civil Aviation Organization (ICAO) recommendations and Health and Safety Executive (HSE)/CAA experience gained from offshore helideck inspections.

Edition 3**October 1998**

Amendments were made to incorporate the results of valuable experience gained by CAA staff during three and a half years of offshore helideck inspecting with the HSE and from cooperation with the British Helicopter Advisory Board (BHAB). Analysis of the results of the inspection regime, completed in April 1995, resulted in changes to the way in which helidecks were authorised for use by helicopter operators. Other changes reflected knowledge gained from accidents, incidents, occurrences and research projects. The section concerning the airflow environment, and the impact on this environment from exhaust and venting systems, was revised. Also the paragraph numbering was changed for easier reference.

Edition 4**September 2002**

The CAP was amended to incorporate new house-style.

Edition 5**August 2005**

The CAP was extensively revised to incorporate valuable experience gained from CAA funded research projects conducted with the support of the UK offshore industry into improved helideck lighting, helideck environmental effects and operations to moving helidecks. The sections concerning helideck lighting were considerably revised to ensure that UK good practice adequately reflected the changes made in 2004 to the ICAO Standards and Recommended Practices (SARPs) for TLOF lighting. The fifth edition also pulled together revised requirements harmonised amongst North Sea States as a result of initiatives taken by the Group of Aerodrome Safety Regulators (GASR) Helideck Working Group.

Edition 6**December 2008**

The sixth edition is revised to incorporate further results of valuable experience gained from CAA funded research projects conducted with the support of the UK offshore industry into improved helideck lighting and the conclusion of projects, jointly funded with the Health and Safety Executive (HSE), relating to offshore helideck environmental issues. In respect of helideck lighting, a detailed specification for stage 2 lighting systems (addressing illumination of the heliport identification 'H' marking and the Touchdown/Positioning Marking Circle) is provided in an Appendix; and a new reference to the final specification for helideck status lights systems is provided in Chapter 4. In regard to now-completed helideck environmental projects, Chapter 3 provides formal notification of the new turbulence criterion and the removal of the long-standing vertical flow criterion.

The sixth edition has also been amended to include new ICAO SARPs relating to offshore helidecks and shipboard heliports, which generally become applicable from November 2009. This edition has also been revised to include material which is part of the fourth edition of the International Chamber of Shipping (ICS) Guide to Helicopter/Ship Operations, published in December 2008. For the first time, provisions are included for the design of winching area arrangements located on wind turbine platforms.

Edition 6 amendment 01/2010**April 2010**

This amendment was issued to provide operators with Additional Guidance Relating

to the Provision of Meteorological Information from Offshore Installations. Editorial amendments convenient to be included at this time have also been incorporated.

Edition 6 amendment 01/2010**August 2010**

This amendment was issued to correct an error in Chapter 10, paragraph 2 that referred to a requirement for a medium intensity (rather than a low intensity) steady red obstruction light. The opportunity has been taken to update part of Chapter 4 relating to helideck lighting and part of Chapter 5 relating to the location of foam-making equipment. Editorial amendments convenient to be included at this time have also been incorporated.

Edition 7**May 2012**

The seventh edition is revised to incorporate the full and final specification for the Helideck Lighting Scheme comprising Perimeter Lights, Lit Touchdown/Positioning Marking Circle and Lit Heliport Identification 'H' Marking.

The seventh edition has also been updated to reflect ICAO SARPs for Annex 14 Volume II due to become applicable for States from November 2013. Provisions for the design of winching area arrangements located on wind turbines, first introduced at the sixth edition, has been reviewed and updated to reflect current best practice with the benefit of lessons learned through various industry forums attended since 2008.

Edition 7 amendment 01/2013**February 2013**

This amendment was issued to clarify aspects of the final specification and installation arrangements for the Lit Touchdown/Positioning Marking Circle and Lit Heliport Identification Marking. Further amendments convenient to be included at this time have also been incorporated.

Edition 8**December 2016**

The eighth edition presents several new topics not previously addressed in CAP 437 including a risk assessment for helicopter operations to helidecks in the UKCS which are sub-1D and criteria for parking areas. In addition there is a comprehensive update on the section related to helideck surface including new friction requirements for flat helidecks with micro-texture finishes and for profiled helidecks. An update on best practice for temporary combined operations, multiple platform configurations

and helideck movement are also included. This amendment is issued to present the final specification and the installation arrangements for the Lit Touchdown/ Positioning Marking Circle and Lit Heliport Identification Marking. Finally the European Aviation Safety Agency (EASA) Requirements for Air Operators, Operational Requirements Part-OPS, Annex VI Part SPA (AMC1 SPA.HOFO.115 Use of offshore locations) are reflected in Appendix material.

Foreword

1. This publication, re-named Standards for Offshore Helicopter Landing Areas at seventh edition, has become an accepted world-wide source of reference. The amendments made to the eighth edition introduce several new topics not previously addressed by CAP 437 including a risk assessment for helicopter operations to helidecks in the UKCS which are sub-1D and criteria for parking areas. In addition there is a comprehensive update on the section related to helideck surfaces including new friction requirements for flat helidecks with micro-texture finishes and for profiled helidecks. An update on best practice for temporary combined operations, multiple platform configurations and operations to moving helidecks are also included. The European Aviation Safety Agency (EASA) Requirements for Air Operators, Operational Requirements Part-OPS, Annex VI Part SPA, which were adopted into EU legislation during summer 2016, are reflected in CAP 437 Appendix material i.e. Appendix A is substantially based on AMC1 SPA.HOFO.115 Use of offshore locations. The eighth edition amendment presents the final specification and installation arrangements for the Lit Touchdown/Positioning Marking Circle and Lit Heliport Identification 'H' Marking. As a consequence of the introduction-to-service of new lighting systems, the CAA, with the full support of the offshore industry, is committed to assist implementation on all existing and new-build installations operating on the UK Continental Shelf (UKCS) by no later than 31st March 2018 if night operations are to continue to be permitted after this date. The CAA believes that the new lighting scheme represents a significant safety enhancement over traditional floodlighting and is working actively with all sectors of the industry to encourage prompt deployment of the new lighting scheme. The TD/PM Circle and Heliport Identification ('H') Marking lighting forms an acceptable alternative to floodlights in International Civil Aviation Organization (ICAO) Annex 14 Volume II and provision of an equivalent circle and H scheme that meets national requirements will effectively be

mandated in Europe, by mid-2018, through the implementation of the European Aviation Safety Agency (EASA) Requirements for Air Operators, Operational Requirements Part-OPS, Annex VI Part SPA, AMC1 SPA.HOFO.115 Use of offshore locations.

2. At international level the UK CAA continues to participate in the ICAO Heliport Design Working Group (HDWG) tasked with the substantial revision of Annex 14 Volume II including a review of the International Standards and Recommended Practices relating to offshore helidecks and shipboard heliports, and supporting guidance material in the Heliport Design and Services Manual (doc. 9261). The latest tranche of amendments were approved by the ICAO Air Navigation Commission (ANC) in 2015, adopted by the Council in March 2016, became effective in July and with applicability to States from November 2016. The amendments, albeit fairly minor, reflect the size of TD/PM Circle and Heliport Identification ('H') painted markings, which may be a smaller size on new helidecks and shipboard heliports which have a D-value below 16.0m. A new ICAO recommendation related to the drive to reduce the height of essential non-frangible objects around a helideck and shipboard heliport, is supported by this 8th Edition of CAP 437, with a recommendation for implementation on new builds by no later than 10 November 2018. Current work programmes of the ICAO HDWG include a comprehensive review of Chapter 6, Rescue and Fire-Fighting Services, and the supporting guidance in the Heliport Design & Services Manual. This substantial piece of work is due to complete in late 2017/ early 2018 and it is anticipated that developments in best practice will be addressed in chapter 5 of a forthcoming update to CAP 437 8th Edition.
3. Also at international level, the UK CAA participated in a technical group that consisted of marine and aviation experts tasked with reviewing and updating the International Chamber of Shipping's (ICS) Guide to Helicopter/Ship Operations. A fourth edition of the Guide was published in December 2008 and current best practice from the ICS Guide is reflected in Chapters 9 and 10 of the eighth edition of CAP 437. The UK CAA is

grateful to the ICS for providing a number of the figures for these chapters.

4. In February 2014, following a series of fatal accidents and incidents in the North Sea, CAA commissioned and published a safety review of offshore public transport helicopter operations in support of the exploitation of oil and gas; reported in CAP 1145. In regard to helidecks it was noted that the CAA's drive to certificate helidecks had received the support of the helicopter operators who viewed a tighter control of the helideck and its environment as a positive step to improving safety. The report added that "certification directly by the CAA or through an appropriately qualified entity would provide the framework for raising standards on helidecks." As a consequence an action (A13) was raised for CAA to assume responsibility for the certification of UK helidecks and to consult with industry on how to achieve this. The outcome from the subsequent consultation conducted via CAP 1295 "Consultation: The CAA's intention to assume responsibility for the certification of UK helidecks", was reported in September 2016 in CAP 1386 "Safety review of offshore public transport helicopter operations in support of the exploitation of oil and gas. Progress report: 2016". Summarising the outcome from the CAP 1295 consultation in May 2015, CAP 1386 noted that, although the CAA-chaired Offshore Helicopter Safety Action Group (OHSAG) was supportive of a certification scheme, it could not be implemented without appropriate legal authority which it was estimated would take several years to establish. As a consequence, in the shorter term CAA plans to enhance oversight of helidecks using existing CAA resources and working towards the final desired solution in collaboration with the Helideck Certification Agency (HCA).
5. Since the mid-1990's the offshore helicopter operators, in seeking to discharge the duty placed on them by the UK Air Navigation Order (ANO) have used the services of the HCA to inspect and certificate helidecks operated on the UKCS, to satisfy the helicopter operators that they are 'fit for purpose'. Previous editions of CAP 47 have noted that the procedure described for authorising the use of helidecks on fixed and floating

installations operating on the UKCS is co-ordinated by the HCA in a process which involves OGUK; the British Rig Owners' Association (BROA); and the International Association of Drilling Contractors (IADC) and members' individual owner/operator safety management systems. RenewablesUK can now be added to the list as HCA also authorise helidecks which are used to service the growing offshore renewable energy sector.

6. In addition to administering the certification process on behalf of the helicopter operators, HCA presently assumes the role of chairing the Helideck Steering Committee (HSC) which includes senior operational flying staff from all the offshore helicopter operators. In future, determining the governance structure of the HSC, and how (specifically by whom) the Helideck Limitations List (HLL) is controlled and amended, will form part of the detailed review needed to develop an effective CAA-led scheme for the certification of helidecks. Currently the HCA Helideck Steering Committee functions to ensure that standardisation is achieved between the offshore helicopter operators in the development and application of operational policies and limitations and that non-compliances, where identified, are treated in a consistent manner by each operator. The HCA publishes these in the Helideck Limitations List (HLL) which contains details of known helidecks including any operator-agreed limitations applied to specific helidecks in order to compensate for any failings or deficiencies in meeting CAP 437 criteria such that the safety of flights is not compromised.
7. Accepting that the process described above is an industry-agreed system, the legal responsibility for the suitability of offshore helicopter landing areas, ahead of the introduction of a legally binding certification scheme, rests ultimately with the helicopter operators. The CAA accepts the process described above as being an acceptable way in which the assessment of the CAP 437 criteria can be made, but is seeking to develop the model into a CAA-led certification scheme. The CAA, in discharging its regulatory responsibility, will audit the application of the process on which the helicopter operator relies. As part of the flight

operations function for the oversight of the AOC holder, the CAA intends to forge closer ties with the HCA to review and audit their procedures and processes, to assess how they assist the present legal responsibilities and requirements of the offshore helicopter operators, and how these arrangements might be used to inform a future CAA-led scheme. At the present time helidecks on the UKCS continue to be regarded as 'unlicensed landing areas' and offshore helicopter operators are required to satisfy themselves that each helideck to which they operate is fit for purpose.

8. CAP 437 presents the criteria required by the CAA in assessing the standards of offshore helicopter landing areas for world-wide use by helicopters registered in the UK. These landing areas may be located on:
 - fixed offshore installations;
 - mobile offshore installations;
 - vessels supporting offshore mineral exploitation;
 - offshore wind farms; or
 - other vessels, e.g. tankers, cargo vessels, passenger vessels.
9. If an offshore helideck does not meet the criteria in CAP 437, or if a change to the helideck environment is proposed, the case should be referred to the HCA in the first instance to enable them to collate information on behalf of the helicopter operators so that the process for authorising the use of the helideck can be completed in a timely fashion. Early consultation with the HCA is essential if maximum helicopter operational flexibility is to be realised and incorporated into the installation design philosophy. It is important that changes are not restricted to consideration of the physical characteristics and obstacle protected surfaces of the helideck. Of equal, and sometimes even greater, importance are changes to the installation or vessel, and to adjacent installation or vessel structures which may affect the local atmospheric environment over the helideck (and adjacent helidecks) or approach and take-off paths. In the case of 'new-builds' or major modifications to existing Installations that may have an effect on helicopter operations, the

CAA has published guidance on helideck design considerations in CAA Paper 2008/03, which is available to assist with the interpretation and the application of criteria stated in CAP 437.

10. The criteria in this publication relating to fixed and mobile installations in the area of the UKCS, whether they are operating for Oil and Gas or renewable energy sectors, provide standards which are accepted by the HSE and referred to in HSE offshore legislation. The criteria address minimum standards required in order to achieve a clearance which will attract no helicopter performance (payload) limitations. CAP 437 is an amplification of internationally agreed standards contained in ICAO Annex 14 to the Convention on International Civil Aviation, Volume II, 'Heliports'. Additionally it provides advice on 'best practice' obtained from many aviation sources. 'Best practice', naturally, should be moving forward continuously and it should be borne in mind that CAP 437 reflects 'current' best practice at the time of publication. There may be alternative equivalent means of meeting the criteria presented in CAP 437 and these will be considered on their merits.
11. Additional criteria are given relating to vessels used in support of offshore mineral exploitation or renewable energy, which are not necessarily subject to HSE offshore regulation and also for other vessels such as tanker, cargo and passenger vessels.
12. In this publication the term 'helideck' refers to all helicopter landing areas on fixed or floating offshore facilities used for the exploration or exploitation of oil and gas. For helicopter landing areas on vessels the term 'shipboard heliport' may be used in preference to 'helideck'.
13. Whenever the term 'CAA' is used in this publication, it means the UK Civil Aviation Authority unless otherwise indicated.
14. As standards for best practice, this document applies the term "should" when referring to either an ICAO Standard or a Recommended Practice. The term "may" is used when a variation or alternative approach could be acceptable to the CAA. The UK HSE accepts that conformance with CAP

437 will demonstrate compliance with applicable offshore regulations. CAP 437 is under continuous review resulting from technological developments and experience; comments are always welcome on its application in practice. The CAA should be contacted on matters relating to interpretation and applicability of these standards and Aviation Law.

Glossary of terms and abbreviations

AAIB	Air Accidents Investigation Branch
AMSL	Above Mean Sea Level
ANC	Air Navigation Commission
ANO	The Air Navigation Order
AOC	Air Operator's Certificate
CAFS	Compressed Air Foam System
CFD	Computational Fluid Dynamics
Class societies	Organisations that establish and apply technical standards to the design and construction of marine facilities including ships.
D-circle	A circle, usually hypothetical unless the helideck itself is circular, the diameter of which is the D-value of the largest helicopter the helideck is intended to serve.
D-value	The largest overall dimension of the helicopter when rotors are turning. This dimension will normally be measured from the most forward position of the main rotor tip path plane to the most rearward position of the tail rotor tip path plane (or the most rearward extension of the fuselage in the case of Fenestron or Notar tails).
DIFFS	Deck Integrated Fire Fighting System(s)
DSV	Diving Support Vessel
EASA	European Aviation Safety Agency
Falling 5:1 gradient	A surface extending downwards on a gradient of 5:1 measured from the edge of the safety netting located around the landing area below the elevation of the helideck to water level for an arc of not less than 180° that passes through the centre of the landing area and outwards to a distance that will allow for safe clearance from obstacles below the helideck in the event of an engine failure for the type of helicopter the helideck is intended to serve. For

	helicopters operated in Performance Class 1 or 2 the horizontal extent of this distance will be compatible with the one-engine inoperative capability of the helicopter type to be used.
FMS	Fixed Monitor System
FOD	Foreign Object Debris/Damage
FPSO	Floating Production Storage and Offloading units
FSU	Floating Storage Unit
HCA	Helideck Certification Agency. The HCA is the certifying agency acting on behalf of the UK offshore helicopter operators that audits and inspects all helidecks and shipboard heliports on offshore installations and vessels operating in UK waters to the standards laid down in CAP 437.
HDWG	Heliport Design Working Group (of ICAO Aerodromes panel)
Helideck	A helicopter landing area located on a fixed or floating offshore facility.
HHOP	Helicopter Hoist Operations Passengers
HLAC	The Helicopter Landing Area Certificate issued by the HCA, and required by UK offshore helicopters operators, to authorise the use of a helideck or shipboard heliport.
HLL	Helideck Limitations List. Published and distributed by the HCA in UKCS or other National Authority accepted bodies in other European States.
HLO	Helicopter Landing Officer
HMS	Helideck Motion System
HSC	Health and Safety Commission
HSE	Health and Safety Executive
IATA	International Air Transport Association
ICAO	International Civil Aviation Organization
ICP	Independent and competent person as defined in the Offshore Installations (Safety Case) Regulations 2005 who is selected to perform functions under the verification scheme.

ICS	International Chamber of Shipping
IMO	International Maritime Organization
ISO	International Organization for Standardization
JIG	Joint Inspection Group
Landing area	A generic term referring to the load-bearing area primarily intended for the landing and take-off of aircraft. The area, sometimes referred to as the Final Approach and Take-Off area (FATO), is bounded by the perimeter line and perimeter lighting.
LED	Light Emitting Diode
LFL	Lower Flammable Limit
LOS	Limited Obstacle Sector(s). The 150° sector within which obstacles may be permitted, provided the height of the obstacles is limited.
MEK	Methyl Ethyl Ketone
MSI	Motion Severity Index
MTOM	Maximum Certificated Take-Off Mass
NAA	National Aviation Authority
NAI	Normally Attended Installation
NDB	Non-Directional Beacon
NM	Nautical Mile(s)
NUI	Normally Unattended Installation
OFS	Obstacle Free Sector. The 210° sector, extending outwards to a distance that will allow for an unobstructed departure path appropriate to the helicopter the helideck is intended to serve, within which no obstacles above helideck level are permitted. For helicopters operated in Performance Class 1 or 2 the horizontal extent of this distance will be compatible with the one-engine inoperative capability of the helicopter type to be used.
OGUK	Oil and Gas UK (formerly known as the United Kingdom Offshore Operators Association (UKOOA)).

OIAC	Offshore Industry Advisory Committee
OIAC-HLG	Offshore Industry Advisory Committee – Helicopter Liaison Group
OIS	Offshore Information Sheet
PAI	Permanently Attended Installation (same as NAI)
PCF	Post-Crash Fire
Perimeter D marking	The marking located in the perimeter line in whole numbers; i.e. the D-value (see above) rounded up or down to the nearest whole number.
PPE	Personal Protective Equipment
RD	Rotor Diameter
RFF	Rescue and Fire Fighting
RFFS	Rescue and Fire-Fighting Services
RMS	Ring-Main System (as an alternative to DIFFS or FMS on an existing installation)
Run-off area	An extension to the Landing Area designed to accommodate a parked helicopter; sometimes referred to as the Parking Area.
SASF	Southern Aviation Safety Forum
Shipboard heliport	A heliport located on a vessel which may be purpose-built or non-purpose-built.
SHR	Significant Heave Rate
TD/PM circle	<p>Touchdown/Positioning Marking Circle. Described as the Aiming Circle in earlier editions of CAP 437, the TD/PM Circle is the aiming point for a normal touchdown (landing) so located that when the pilot's seat is over the marking, the whole of the undercarriage will be within the landing area and all parts of the helicopter will be clear of any obstacles by a safe margin.</p> <p>NOTE: It should be noted that only correct positioning over the TD/PM Circle will ensure proper clearance with respect to physical obstacles and provision of ground effect and provision of adequate passenger access/egress.</p>

UKCS	UK Continental Shelf (Geographical area)
UPS	Uninterruptable Power Supply
Verification scheme	A suitable written scheme as defined in the Offshore Installations (Safety Case) Regulations 2005 for ensuring the suitability and proper maintenance of safety-Critical Elements (SCEs).
VMC	Visual Meteorological Conditions
WMO	World Meteorological Organization
WSI	Wind Severity Index
WTG	Wind Turbine Generator

Chapter 1

Introduction

History of development of criteria for offshore helicopter landing areas, 1964-1973

- 1.1 In the early 1960s it became apparent that there would be a continuing requirement for helicopter operations to take place on fixed and mobile offshore installations. Various ideas were put forward by oil companies and helicopter operators as to the appropriate landing area standards for such operations. In 1964, draft criteria were published which used helicopter rotor diameter as a determinant of landing area size and associated obstacle-free area. In the light of experience and after further discussions, the criteria were amended and re-published in 1968. These criteria were then, and still are, based upon helicopter overall length (from the most forward position of main rotor tip to the most rearward position of tail rotor tip plane path, or rearmost extension of the fuselage in the case of fenestron or Notar tails). This length is commonly referred to as 'D' for any particular helicopter as the determinant of landing area size, associated characteristics, and obstacle-protected surfaces.

Department of Energy and the Health and Safety Executive guidance on the design and construction of offshore installations, 1973 onwards

- 1.2 In the early 1970s, the Department of Energy began the process of collating guidance standards for the design and construction of 'installations' – both fixed and mobile. This led to the promulgation of the Offshore Installations (Construction and Survey Regulations) 1974, which were accompanied by an amplifying document entitled 'Offshore Installations: Guidance on the design and construction of offshore installations' (the 4th Edition Guidance). This guidance included criteria for

helicopter landing areas which had been slightly amended from those issued in 1968. During 1976 and 1977, the landing area criteria were developed even further during a full-scale revision of this document, following consultations between the CAA, the British Helicopter Advisory Board and others. This material was eventually published in November 1977 and amended further in 1979. This latter amendment introduced the marking of the landing area to show the datum from which the obstacle-free area originated, the boundary of the area, and the maximum overall length of helicopter for which operations to the particular landing area were suitable. The first edition of CAP 437 was published in 1981, amended in 1983 and revised in December 1993 (second edition) and October 1998 (third edition). Following a further amendment in January 2001, a fourth edition of CAP 437, incorporating the new house style, was placed on the Publications section of the CAA website at www.caa.co.uk in September 2002. This was superseded by the fifth edition of CAP 437 in August 2005 and a sixth edition in December 2008. Following two interim amendments, a seventh edition was published in May 2012 and updated in February 2013. The major changes incorporated into this latest eighth edition are summarised in the revision history on page 11.

- 1.3 In April 1991 the Health and Safety Commission (HSC) and the Health and Safety Executive (HSE) took over from the Department of Energy the responsibility for offshore safety regulation. The Offshore Safety Act 1992, implementing the Cullen recommendations following the Piper Alpha disaster, transferred power to the HSE on a statutory footing. The HSE also took over sponsorship of the 4th Edition and Section 55 'Helicopter landing areas' referring to all installations.
- 1.4 Since April 1991, the HSE has introduced five sets of modern goal-setting regulations which contain provisions relating to helicopter movements and helideck safety on offshore installations. These update and replace the old prescriptive legislation. The provisions are as follows:

	Regulations	Covers
1	<p>The Offshore Installations (Safety Case) Regulations 2005 (SCR) (SI 2005/3117)</p> <p>These regulations remain applicable until the installation has transitioned its safety case to SCR 2015 as required by Regulation 39 and Schedule 14</p>	<p>Regulation 2(1) defines a major accident and this includes the collision of a helicopter with an installation. Regulation 2(1) defines safety-critical elements (SCEs) and Regulation 2(5) refers to a verification scheme for ensuring by means described in Regulation 2(6) that the SCEs will be suitable and remain in good repair and condition. Helidecks and their associated systems are deemed to be SCEs. Regulation 6 requires the submission of a design notification containing the particulars specified in Schedule 1. Regulation 12(1) requires that a safety case should demonstrate: the adequacy of the safety management system to ensure compliance with relevant statutory provisions; the adequacy of arrangements for audit; that all hazards with the potential to cause a major accident have been identified and evaluated; and that measures have been taken to ensure that the relevant statutory provisions will be complied with.</p>
2	<p>The Offshore Installations (Offshore Safety Directive)(Safety Case etc) Regulations 2015 (SCR 2015)</p>	<p>Regulation 2 defines a major accident and this includes an event involving a fire, explosion... causing, or with a significant potential to cause death or serious personal injury to persons on the installation or engaged in an activity on or in connection with it. It also is defined as an event involving major damage to the structure of the installation or plant affixed to it. Although the specific SCR 2005 reference to helicopter collision has been removed, both of these SCR 2015 definitions are taken to include helicopter collision. Regulation 2 defines safety and environment-critical elements (SECEs) and Regulations 9 and 10 refer to a verification scheme for ensuring that the SECEs will be suitable and remain in good repair and condition. Helidecks and their associated systems are deemed to be SECEs. Regulations 15 and 19 require the submission of a design notification containing the particulars specified in Schedule 5. Regulation 16(1) requires that a safety case should demonstrate: the adequacy of the safety management system to ensure compliance with</p>

		relevant statutory provisions; the adequacy of arrangements for audit; that all major accident risks have been identified and evaluated; and that suitable measures will be taken to control those risks and to ensure that the relevant statutory provisions will be complied with.
3	The Offshore Installations (Prevention of Fire and Explosion, and Emergency Response) Regulations 1995 (PFEER) (SI 1995/743)	<p>Regulation 6(1)(c) requires a sufficient number of personnel trained to deal with helicopter emergencies to be available during helicopter movements. Regulation 7 requires the operator/owner of a fixed/mobile installation to ensure that equipment necessary for use in the event of an accident involving a helicopter is kept available near the helicopter landing area. Equipment provided under Regulation 7 must comply with the suitability and condition requirements of Regulation 19(1) of PFEER.</p> <p>Regulations 9, 12 and 13 make general requirements for the prevention of fire and explosion, the control of fire and explosion which would take in helicopter accidents. Regulation 17 of PFEER requires arrangements to be made for the rescue of people near the installation from helicopter ditchings.</p>
4	The Offshore Installations and Pipeline Works (Management and Administration) Regulations 1995 (MAR) (SI 1995/738)	<p>Regulation 8 requires people to co-operate with the Helicopter Landing Officer to enable him to perform his function referred to in Regulation 13. Regulation 11 requires comprehensible instructions to be put in writing and brought to the attention of everybody to whom they relate. Circumstances where written instructions might be needed include helideck operations (particularly if involving part-time helideck crew). Regulation 12(b) requires arrangements which are appropriate for health and safety purposes to be in place for effective communication between an installation, the shore, aircraft and other installations. Arrangements must also be in place for effective communication where a helicopter is to land on or take off from an installation aboard which there will be no person immediately before landing or after the take-off, and between the helicopter and a suitable offshore installation with persons on board or, where there is no suitable installation, suitable premises ashore. Regulation 13 requires the operator/owner of a fixed/mobile installation to</p>

		<p>ensure that a competent person is appointed to be in control of helideck operations on the installation (i.e. the Helicopter Landing Officer (HLO)), is present on the installation and is in control throughout such operations, and procedures are established and plant provided as will secure so far as is reasonably practicable that helideck operations including landing/take-off are without risks to health and safety. Regulation 14 requires the duty holder to make arrangements for the collection and keeping of meteorological and oceanographic information and information relating to the movement of the offshore installation. This is because environmental conditions may affect helicopter operations and the ability to implement emergency plans. Regulation 19 requires the operator/owner of an offshore installation to ensure that the installation displayed its name in such a manner as to make the installation readily identifiable by sea or air; and displays no name, letters or figures likely to be confused with the name or other designation of another offshore installation.</p>
5	The Offshore Installations and Wells (Design and Construction, etc.) Regulations 1996 (DCR) (SI 1996/913)	<p>Regulation 11 – Helicopter Landing Area requires the operator/owner of a fixed/mobile installation to ensure that every landing area forming part of an installation is large enough, and has sufficient clear approach/departure paths, to enable any helicopter intended to use the landing area safely to land and take off in any wind and weather conditions permitting helicopter operations, and is of a design and construction adequate for its purpose.</p>
<p>The HSE has published guidance documents on SCR, SCR 2015, MAR and DCR and, in the case of PFEER, combined guidance and an Approved Code of Practice.</p>		

- 1.5 In February 2005 UKOOA (now OGUK) published “Guidelines for the Management of Offshore Helideck Operations” (Issue 5) preceded in 2004 by an HSE publication “Offshore Helideck Design Guidelines” which was sponsored by the HSE and the CAA, and endorsed by the Offshore Industry Advisory Committee – Helicopter Liaison Group (OIAC-HLG). The UKOOA ‘Guidelines’ have now been superseded by the Oil and Gas

UK “Guidelines for the Management of Aviation Operations” (Issue 6, April 2011) which are in the process of being updated. The “Offshore Helideck Design Guidelines” have been withdrawn by the HSE and the OIAC has been replaced by OMAHAC (Offshore Major Accident Hazard Advisory Committee) but with no dedicated Helicopter Liason Group attached.

Applicability of standards in other cases

- 1.6 For vessels engaged in supporting mineral exploitation (such as crane or derrick barges, pipe-laying vessels, diving support vessels, seismic research vessels, etc.), which are not classed as ‘offshore installations’ and so are not subject to a verification scheme, the CAA recommends the application of the Chapter 9 standards for helicopter landing areas as contained in this CAP. Compliance with this recommendation will enable helicopter operators to fulfil their own legal obligations and responsibilities.
- 1.7 On other merchant vessels where it is impracticable for these standards to be achieved, for example where the landing area has to be located amidships or is non-purpose-built on a ship’s side, further criteria to be used are included in Chapter 9 of this publication. Criteria for helicopter winching areas on ships and on renewable energy wind turbines are presented in Chapter 10. For heli-hoist operations, whether to shipboard winching areas or at wind turbines, specific operational guidance should be obtained from the helicopter operator or, where a query has to do with the design of the winching area, from the agency responsible for certification of the winching area.

Worldwide application

- 1.8 It should be noted that references are made to United Kingdom legislative and advisory bodies. However, this document is written so that it may provide minimum standards applicable for the safe operation of helicopters to offshore helidecks throughout the world.
- 1.9 CAP 437 is therefore particularly relevant to UK (G) registered helicopters operating within and outside the UKCS areas; whether or not they have

access to the UK authorisation process. In cases where the UK authorisation process is not applicable or available, helicopter operators should have in place a system for assessing and authorising the operational use of each helideck. Within Europe, through the European Aviation Safety Agency (EASA) Requirements for Air Operators, Operational Requirements Part-OPS, Annex VI Part SPA, authorisation of each helicopter landing area is a specific requirement laid down in Part HOFO (Helicopter Offshore Operations) with guidance on the criteria for use of offshore locations given in an 'acceptable means of compliance' (AMC) (AMC1 SPA.HOFO.115 'Use of offshore locations' which is reproduced in CAP 437, Appendix A). Throughout the range of operations covered by Part-SPA.HOFO, agreement has been made to share all helideck information between helicopter operators by the fastest possible means. An example of a typical template is shown in Figure 1 of GM1 SPA.HOFO.115.

- 1.10 Other helicopter operators, who operate outside the areas covered by EASA Requirements for Air Operators and who are using this document, are recommended to establish a system for assessing and authorising each helideck for operational use. It is a fact that many installations and vessels do not fully comply with the criteria contained in the following chapters. A system for the assessment of the level of compliance, with processes and procedures for the management of rectification actions (where practicable) plus a system for imposing compensating operational limitations (where rectification actions are impractical), is often the only fail-safe way of ensuring that the level of safety to flights is not compromised.

Chapter 2

Helicopter performance considerations

General considerations

- 2.1 The criteria for helicopter landing areas on offshore installations and vessels result from the need to ensure that UK registered helicopters are afforded sufficient space to be able to operate safely at all times in the varying conditions experienced offshore.
- 2.2 The helicopter's performance requirements and handling techniques are contained in the Rotorcraft Flight Manual and/or the operator's Operations Manual.
- 2.3 Helicopter companies operating for public transport are required to hold an AOC which is neither granted nor allowed to remain in force unless they provide procedures for helicopter crews which safely combine the space and performance requirements mentioned above.

Safety philosophy

- 2.4 Aircraft performance data is scheduled in the Flight Manual and/or the Operations Manual which enables flight crew to accommodate the varying ambient conditions and operate in such a way that the helicopter has sufficient space and sufficient engine performance to approach, land on and take off from helidecks in safety.
- 2.5 Additionally, Operations Manuals recognise the remote possibility of a single engine failure in flight and state the flying procedures and performance criteria which are designed to minimise the exposure time of the aircraft and its occupants during the short critical periods during the initial stage of take-off, or final stage of landing.

Factors affecting performance capability

2.6 On any given day helicopter performance is a function of many factors including the actual all-up mass; ambient temperature; pressure altitude; effective wind speed component; and operating technique. Other factors, concerning the physical and airflow characteristics of the helideck and associated or adjacent structures, will also combine to affect the length of the exposure period referred to in paragraph 2.5. These factors are taken into account in the determination of specific and general limitations which may be imposed in order to ensure adequate performance and to ensure that the exposure period is kept to a minimum. In many circumstances the period will be zero. It should be noted that, following a rare power unit failure, it may be necessary for the helicopter to descend below deck level to gain sufficient speed to safely fly away, or in extremely rare circumstances to land on the water. In certain circumstances, where exposure periods would otherwise be unacceptably long, it will probably be necessary to reduce helicopter mass (and therefore payload) or even to suspend flying operations.

Chapter 3

Helicopter landing areas – Physical characteristics

General

- 3.1 This chapter provides criteria on the physical characteristics of helicopter landing areas (helidecks) on offshore installations and some vessels. Where a scheme of verification is required it should state for each helicopter landing area the maximum size (overall length) of the helicopter authorised to use the landing area expressed in terms of D-value and the maximum allowable take-off mass (MTOM) of the helicopter for which that area is being authorised with regard to its structural limitations, expressed as a 't' value. Where criteria cannot be met in full for a particular type of helicopter it may be necessary to promulgate operational restrictions in order to compensate for deviations from these criteria. The helicopter operators are notified of any restrictions through the Helideck Limitations List (HLL).
- 3.2 The criteria which follow are based on helicopter overall length and mass. This data is summarised in Table 1 below.

Table 1: D-value, 't' value and other helicopter type criteria

Type	D-value (m)	Perimeter 'D' marking	Rotor diameter (m)	Max weight (kg)	't' value	Landing net size
Bolkow Bo 105D	12.00	12	9.90	2400	2.4	Not recommended
EC 135 T2+	12.20	12	10.20	2910	2.9	Not recommended
Bolkow 117	13.00	13	11.00	3200	3.2	Not recommended
Agusta A109	13.05	13	11.00	2600	2.6	Small

Dauphin AS365 N2	13.68	14	11.93	4250	4.3	Small
Dauphin AS365 N3	13.73	14	11.94	4300	4.3	Small
EC 155B1	14.30	14	12.60	4850	4.9	Medium
Sikorsky S76	16.00	16	13.40	5307	5.3	Medium
Agusta/Westland AW 139	16.63	17	13.80	6800	6.8	Medium
Agusta/Westland AW 189	17.60	18	14.60	8600	8.6t	Medium
Airbus H175	18.06	18	14.80	7500	7.5	Medium
Super Puma AS332L	18.70	19	15.60	8599	8.6t	Medium
Bell 214ST	18.95	19	15.85	7938	7.9t	Medium
Super Puma AS332L2	19.50	20	16.20	9300	9.3t	Medium
EC 225 (H225)	19.50	20	16.20	11000	11.0t	Medium
Sikorsky S92A	20.88	21	17.17	12565	12.6t	Large
Sikorsky S61N	22.20	22	18.90	9298	9.3t	Large
AW101	22.80	23	18.90	14600	14.6t	Large

NOTE: Where skid-fitted helicopters and/or a deck integrated fire fighting system (DIFFS) are in use landing nets should not be fitted.

Helideck design considerations – Environmental effects

Introduction

3.3 The safety of helicopter flight operations can be seriously degraded by environmental effects that may be present around installations or vessels and their helidecks. The term “environmental effects” is used here to represent the effects of the installation or vessel and/or its systems and/or processes on the surrounding environment, which result in a degraded local environment in which the helicopter is expected to operate. These

environmental effects are typified by structure-induced turbulence, turbulence and thermal effects caused by gas turbine exhausts, thermal effects of flares and diesel exhaust emissions, and unburnt hydrocarbon gas emissions from cold flaring or, more particularly, emergency blow-down systems. It is almost inevitable that helidecks installed on the cramped topsides of offshore installations will suffer to some degree from one or more of these environmental effects, and controls in the form of operational restrictions may be necessary in some cases. Such restrictions can be minimised by careful attention to the design and layout of the installation topsides and, in particular, the location of the helideck.

3.4 Advice on the design and placement of offshore helidecks is provided in this document, and includes certain environmental criteria (see paragraph 3.8). These criteria have been set to define safe operating boundaries for helicopters in the presence of known environmental hazards. Where these criteria cannot be met, a limitation is placed in the HLL. These entries are usually specific to particular combinations of wind speed and direction, and either restrict helicopter mass (payload), or prevent flying altogether in certain conditions.

3.5 The HLL system is operated for the benefit of the offshore helicopter operators and should ensure that landings on offshore helidecks are properly controlled when adverse environmental effects are present. On poorly designed helidecks, severe operational restrictions may result, leading to significant commercial penalties for an installation operator or vessel owner. Well designed and ‘helicopter friendly’ platform topsides and helidecks should result in efficient operations and cost savings for the installation operator.

NOTE: It is important that the helicopter operators through the agency responsible for the certification of the helideck are always consulted at the earliest stage of design to enable them to provide advice and information so that the process for authorising the use of the helideck can be completed in a timely fashion and in a manner which ensures that maximum helicopter operational flexibility is realised. Information from helideck flow assessment studies (see paragraphs 3.9 and

3.10) should be made available to the helicopter operators as early as possible to enable them to identify any potential adverse environmental effects that may impinge on helicopter flight operations and which, if not addressed at the design stage, could lead to operational limitations being imposed to ensure that safety is not compromised.

Helideck design guidance

- 3.6 A review of offshore helideck environmental issues (see CAA Paper 99004) concluded that many of the decisions leading to poor helideck operability had been made in the very early stages of design, and recommended that it would be easier for designers to avoid these pitfalls if comprehensive helideck design guidance was made available to run in parallel with CAP 437. As part of the subsequent research programme, material covering environmental effects on offshore helideck operations was commissioned by the HSE and the CAA. This material is now presented in CAA Paper 2008/03: “Helideck Design Considerations – Environmental Effects” and is available on the Publications section of the CAA website at www.caa.co.uk/publications. It is strongly recommended that platform designers and offshore duty holders consult CAA Paper 2008/03 at the earliest possible stage of the design process.
- 3.7 The objective of CAA Paper 2008/03 is to help platform designers to create offshore installation topside designs and helideck locations that are safe and ‘friendly’ to helicopter operations by minimising exposure to environmental effects. It is hoped that, if used from ‘day one’ of the offshore installation design process when facilities are first being laid out, this manual will prevent or minimise many helideck environmental problems at little or no extra cost to the design or construction of the installation. See also HSE Offshore Information sheet (OIS) No. 5/2011, issued June 2011.

Design criteria

- 3.8 The design criteria given in the following paragraphs represent the current best information available and should be applied to new installations, to

significant modifications to existing installations, and to combined operations (where a mobile platform or vessel is operating in close proximity to another installation). In the case of multiple platform configurations, the design criteria should be applied to the arrangement as a whole.

NOTE: When considering the volume of airspace to which the following criteria apply, installation designers should consider the airspace up to a height above helideck level which takes into consideration the requirement to accommodate helicopter landing and take-off decision points or committal points. This is deemed to be up to a height above the helideck corresponding to 30 ft plus wheels-to-rotor height plus one rotor diameter.

3.9 All new-build offshore helidecks, modifications to existing topside arrangements which could potentially have an effect on the environmental conditions around an existing helideck, or helidecks where operational experience has highlighted potential airflow problems should be subject to appropriate wind tunnel testing or Computational Fluid Dynamics (CFD) studies to establish the wind environment in which helicopters will be expected to operate. As a general rule, a limit on the standard deviation of the vertical airflow velocity of 1.75 m/s should not be exceeded. The helicopter operator should be informed at the earliest opportunity of any wind conditions for which this criterion is not met. Operational restrictions may be necessary.

NOTE 1: Following completion of the validation exercise, the provisional limit on the standard deviation of the vertical airflow velocity of 2.4 m/s specified in CAP 437 fifth edition was lowered to a threshold advisory limit of 1.75 m/s. This change was made to allow for flight in reduced cueing conditions, for the less able or experienced pilot, and to better align the associated measure of pilot workload with operational experience. However, it was known at the time that the lower criterion is close to onshore background turbulence levels, and that it would be unusual for a helideck not to exceed the lower threshold limit for at least some wind speeds and directions. In consideration of this the lower threshold limit of 1.75 m/s is intended to draw attention to conditions that might result in operating difficulties and to alert pilots to exercise caution, unless, or until, operating

experience has confirmed the airflow characteristics to be acceptable. Therefore the lower limit functions as the baseline which may be refined in light of in-service experience. Conversely if the airflow significantly exceeds the upper criterion of 2.4 m/s it may be advisable to consider modifications to the helideck to improve airflow (such as by increasing the air-gap), if operating restrictions are to be avoided. It is recommended that use is made of the helicopter operators' existing operations monitoring programmes to include the routine monitoring of pilot workload and that this be used to continuously inform and enhance the quality of the HLL entries for each platform (see CAA Paper 2008/02 – Validation of the Helicopter Turbulence Criterion for Operations to Offshore Platforms).

NOTE 2: Following the establishment of the new turbulence criterion for helicopters operating to offshore installations, the need for retention of the long-standing CAP 437 criterion related to a vertical wind component of 0.9 m/s has been reviewed. As it has not been possible to link the criterion to any helicopter performance (i.e. torque related) or handling (pilot work related) hazard, it is considered that the vertical mean wind speed criterion can be removed from CAP 437. The basis for the removal from CAP 437 is described in detail in CAA Paper 2008/02 Study II – A Review of 0.9 m/s Vertical Wind Component Criterion for Helicopters Operating to Offshore Installations.

3.10 Unless there are no significant heat sources on the installation or vessel, offshore duty holders should commission a survey of ambient temperature rise based on a Gaussian dispersion model and supported by wind tunnel tests or CFD studies for new-build helidecks, for significant modifications to existing topside arrangements, or for helidecks where operational experience has highlighted potential thermal problems. When the results of such modelling and/or testing indicate that there may be a rise of air temperature of more than 2°C (averaged over a three-second time interval), the helicopter operator should be consulted at the earliest opportunity so that appropriate operational restrictions may be applied.

3.11 Previous editions of CAP 437 have suggested that 'some form of exhaust plume indication should be provided for use during helicopter operations, for example, by the production of coloured smoke'. Research has been conducted into the visualisation of gas turbine exhaust plumes and

guidance on how this can be achieved in practice has been established. This work is now reported in CAA Paper 2007/02 which recommends that consideration should be given to installing a gas turbine exhaust plume visualisation system on platforms having a significant gas turbine exhaust plume problem in order to highlight the hazards to pilots and thereby minimising its effects by making it easier to avoid encountering the plume. It is further recommended that use is made of the helicopter operators' existing operations monitoring programmes to establish and continuously monitor the temperature environments around all offshore platforms. This action is aimed at identifying any 'problem' platforms, supporting and improving the contents of the HLL, identifying any new problems caused by changes to platform topsides or resulting from combined operations, and identifying any issues related to flight crew training or procedures.

- 3.12 The maximum permissible concentration of hydrocarbon gas within the helicopter operating area is 10% Lower Flammable Limit (LFL). Concentrations above 10% LFL have the potential to cause helicopter engines to surge and/or flame out with the consequent risk to the helicopter and its passengers. It should also be appreciated that, in forming a potential source of ignition for flammable gas, the helicopter can pose a risk to the installation itself. It is considered unlikely that routine 'cold flaring' will present any significant risk, but the operation of emergency blow-down systems should be assumed to result in excessive gas concentrations. Installation operators should have in place a management system which ensures that all helicopters in the vicinity of any such releases are immediately advised to stay clear.

NOTE: The installation of 'Status Lights' systems (see Chapter 4, paragraph 4.25) is not considered to be a solution to all potential flight safety issues arising from hydrocarbon gas emissions; these lights are only a visual warning that the helideck is in an unsafe condition for helicopter operations.

- 3.13 For 'permanent' multiple platform configurations, usually consisting of two or more bridge-linked fixed platforms in close proximity, where there is a physical separation of the helideck from the production and process

operation, the environmental effects of hazards emanating from the 'remote' production platform should be considered on helideck operations. This is particularly appropriate for the case of hot or cold gas exhausts where there will always be a wind direction that carries any exhaust plumes from a neighbouring platform (bridge-linked module) in the direction of the helideck.

- 3.14 For 'temporary' combined operations, where one mobile installation or vessel (e.g. a flotel) is operated in close proximity to a fixed installation, the environmental effects of hazards emanating from one installation (or vessel) on the other installation (or vessel) should be fully considered. This 'assessment' should consider the effect of the turbulent wake from one platform impinging on the helideck of the other, and of any hot or cold gas exhausts from one installation or vessel influencing the approach to the other helideck. On occasions there may be more than two installations and/or vessels in a 'temporary combined' arrangement. Where this is the case, the effect of turbulent wake and hot gas exhausts from each installation or vessel on all helideck operations within the combined arrangement should be considered.

NOTE: Paragraphs 3.13 and 3.14 are primarily concerned with the issue of environmental effects on the helideck design. In respect of permanent multi-platform configurations and 'temporary' combined operations there are a number of other considerations that may need to be addressed. These include, but may not be limited to, the effect of temporary combined operations on helideck obstacle protection criteria. Additional considerations are described in more detail in Chapter 3 paragraphs 3.31 to 3.33 (Temporary Combined Operations) and in paragraphs 3.34 to 3.36 (Multiple Platform Configurations).

Structural design

- 3.15 The take-off and landing area should be designed for the heaviest and largest helicopter anticipated to use the facility (see Table 1). Helideck structures should be designed in accordance with relevant International Organization for Standardization (ISO) codes for offshore structures and for floating installations. The maximum size and mass of helicopters for

which the helideck has been designed should be stated in the Installation Operations Manual and Verification and/or Classification document. For structural design requirements for helicopter landing areas located on vessels (i.e. non-installations), reference may be made to appropriate Class Society rules.

3.16 Optimal operational flexibility may be gained from considering the potential life and usage of the facility along with likely future developments in helicopter design and technology.

3.17 Consideration should also be given in the design to other types of loading such as personnel, other traffic, snow and ice, freight, refuelling equipment, rotor downwash etc. as stated in the relevant ISO codes or Class Society rules. It may be assumed that single main rotor helicopters will land on the wheel or wheels of two landing gear (or both skids if fitted). The resulting loads should be distributed between two main undercarriages. Where advantageous a tyre contact area may be assumed in accordance with the manufacturer's specification. Working stress design or ultimate limit state (ULS) methods may be used for the design of the helideck structure, including girders, trusses, pillars, columns, plating and stiffeners. A serviceability limit check should also be performed to confirm that the maximum deflection of the helideck under maximum load is within code limits. This check is intended to reduce the likelihood of the helideck structure being so damaged during an emergency incident as to prevent other helicopters from landing.

NOTE: Requirements for the structural design of helidecks are comprehensively set out in ISO 19901-3 Petroleum and natural gas industries – Specific requirements for offshore structures, Part 3: Topsides structure (first published in December 2010).

3.18 Consideration should be given to the possibility of accommodating an unserviceable helicopter in a designated parking or run-off area (where provided) adjacent to the helideck to allow a relief helicopter to land. If this contingency is designed into the construction/operating philosophy of the

installation, the helicopter operator should be advised of any weight restrictions imposed on the relief helicopter by structural integrity considerations. Where a parking or run-off area is provided it is assumed that the structural considerations will at least meet the loads criteria applicable for helicopters at rest (see paragraph 3.21). Parking areas are addressed in more detail in paragraphs 3.59 to 3.62.

- 3.19 Alternative loading criteria equivalent to those recommended here and in paragraphs 3.20 and 3.21 may be used where aircraft-specific loads have been derived by the aircraft manufacturer from a suitable engineering assessment taking account of the full range of potential landing conditions, including failure of a single engine at a critical point, and the behaviour of the aircraft undercarriage and the response of the helideck structure. The aircraft manufacturer should provide information to interested parties, including the owner or operator of the installation and the helicopter operators to justify use of alternative criteria. The aircraft manufacturer may wish to seek the opinion of the CAA on the basis of the criteria to be used. In consideration of alternative criteria, the CAA is content to assume that a single engine failure represents the worst case in terms of rate of descent on to the helideck amongst likely survivable emergencies.

Loads

Helicopters landing

- 3.20 The helideck should be designed to withstand all the forces likely to act when a helicopter lands. The loads and load combinations to be considered should include:
- 1) **Dynamic load due to impact landing.** This should cover both a heavy normal landing and an emergency landing. For the former, an impact load of 1.5 x MTOM of the design helicopter should be used, distributed as described in paragraph 3.17. This should be treated as an imposed load, applied together with the combined effect of 1) to

7) in any position on the landing area so as to produce the most severe load on each structural element. For an emergency landing, an impact load of 2.5 x MTOM should be applied in any position on the landing area together with the combined effects of 2) to 7) inclusive. Normally, the emergency landing case will govern the design of the structure.

- 2) **Sympathetic response of landing platform.** After considering the design of the helideck structure's supporting beams and columns and the characteristics of the designated helicopter, the dynamic load (see 1) above) should be increased by a suitable structural response factor depending upon the natural frequency of the helideck structure. It is recommended that a structural response factor of 1.3 should be used unless further information derived from both the helideck manufacturer and the helicopter manufacturer will allow a lower factor to be calculated. Information required to do this will include the natural periods of vibration of the helideck and the dynamic characteristics of the design helicopter and its landing gear.
- 3) **Overall superimposed load on the landing platform.** To allow for any appendages that may be present on the deck surface (e.g. helideck net, "H" and circle lighting etc.) in addition to wheel loads, an allowance of 0.5 kiloNewtons per square metre (kN/m²) should be added over the whole area of the helideck.
- 4) **Lateral load on landing platform supports.** The landing platform and its supports should be designed to resist concentrated horizontal imposed loads equivalent to 0.5 x MTOM of the helicopter, distributed between the undercarriages in proportion to the applied vertical loading in the direction which will produce the most severe loading on the element being considered.
- 5) **Dead load of structural members.** This is the normal gravity load on the element being considered.
- 6) **Wind loading.** Wind loading should be allowed for in the design of the platform. The helideck normal restricting wind conditions (i.e. 60 knots equivalent to 31 m/s) should be applied in the direction which,

together with the imposed lateral loading, will produce the most severe loading condition on each structural element.

- 7) **Inertial actions due to platform motions for floating installations.** The effects of accelerations and dynamic amplification arising from the predicted motions of a floating platform in a storm condition with a 10-year return period should be considered.
- 8) **Punching shear check (applicable to wooden or concrete structures).** A check should be made for the punching shear from a wheel of the landing gear with a contact area of $65 \times 10^3 \text{ mm}^2$ acting in any probable location. Particular attention to detailing should be taken at the junction of the supports and the platform deck.

Helicopters at rest

3.21 The helideck should be designed to withstand all the applied forces that could result from a helicopter at rest; the following loads should be taken into account:

- 1) **Imposed load from helicopter at rest.** All areas of the helideck accessible to a helicopter, including any separate parking or run-off area, should be designed to resist an imposed load equal to the MTOM of the design helicopter. This load should be distributed between all the landing gear. It should be applied in any position on the helideck so as to produce the most severe loading on each element considered.
- 2) **Overall superimposed load.** To allow for personnel, freight, refuelling equipment and other traffic, snow and ice, rotor downwash etc., an allowance of 2.0 kiloNewtons per square metre (kN/m²) should be added to the whole area of the helideck.
- 3) **Dead load and wind load.** The values for these loads are the same as given in paragraph 3.20 5) and 6) and should be considered to act simultaneously in combination with paragraph 3.21 1) and 2). Consideration should also be given to the additional wind loading from any parked or secured helicopter.

- 4) **Acceleration forces and other dynamic amplification forces.** The effect of these forces, arising from the predicted motions of mobile installations and vessels, in the appropriate environmental conditions corresponding to a 10-year return period, should be considered.

Size and obstacle protected surfaces

NOTE: The location of a specific helideck is often a compromise given the competing requirements for space. Helidecks should be at or above the highest point of the main structure. This is a desirable feature but it should be appreciated that if this entails a landing area much in excess of 60 m above sea level, the regularity of helicopter operations may be adversely affected in low cloud base conditions.

3.22 For any particular type of single main rotor helicopter, the helideck should be sufficiently large to contain a circle of diameter D equal to the largest dimension of the helicopter when the rotors are turning. This D-circle should be totally unobstructed (see Table 1 for D values). Due to the actual shape of most offshore helidecks the D-circle will be 'hypothetical' but the helideck shape should be capable of accommodating such a circle within its physical boundaries.

3.23 From any point on the periphery of the above mentioned D-circle an obstacle-free approach and take-off sector should be provided which totally encompasses the landing area (and D-circle) and which extends over a sector of at least 210°. Within this sector obstacle accountability should be considered out to a distance from the periphery of the landing area that will allow for an unobstructed departure path appropriate to the helicopter the helideck is intended to serve. For helicopters operated in Performance Class 1 or 2 the horizontal extent of this distance from the helideck will be based upon the one-engine inoperative capability of the helicopter type to be used. In consideration of the above, only the following items essential for safe helideck operations may exceed the height of the landing area, but should not do so by more than 25 centimetres. For new build helidecks completed on or after 10 November 2018 and for refurbishments, the height of essential items around the

helideck should not exceed 15 cm for any helideck where the D-value is greater than 16.01 m. For helidecks, where the D-value is 16.00 m or less the height of essential items around the helideck should not exceed 5 cm. Essential items include:

- the guttering (associated with the requirements in paragraph 3.44);
- the lighting required by Chapter 4;
- the foam monitors (where provided); and
- those handrails and other items (e.g. EXIT sign) associated with the landing area which are incapable of complete retraction or lowering for helicopter operations.

3.24 Objects whose function requires that they be located on the surface of the helideck such as landing nets, tie-down points, and “circle” and “H” lighting systems (see Appendix C) should not exceed a height of 25 mm. Such objects should only be present above the surface of the touchdown area provided they do not cause a hazard to helicopter operations.

3.25 The bisector of the 210° Obstacle Free Sector (OFS) should normally pass through the centre of the D-circle. The sector may be ‘swung’ by up to 15° as illustrated in Figure 1. Acceptance of the ‘swung’ criteria will normally only be applicable to existing installations.

NOTE: If the 210° OFS is swung, then it would be normal practice to swing the 180° falling 5:1 gradient by a corresponding amount to indicate, and align with, the swung OFS.

3.26 The diagram at Figure 1 shows the extent of the two segments of the 150° Limited Obstacle Sector (LOS) and how these are measured from the centre of the (hypothetical) D-circle and from the perimeter of the landing area. This diagram assumes, since most helidecks are designed to the minimum requirement of accommodating a 1 D-circle, that the D-circle perimeter and landing area perimeter are coincidental. No objects above 25 cm (or 5 cm where the D-value of the helideck is 16.00 m or less) are permitted in the first (hatched area in Figure 1) segment of the LOS. The first segment extends out to 0.62D from the centre of the D-circle, or

0.12D from the landing area perimeter marking. The second segment of the LOS, in which no obstacles are permitted to penetrate, is a rising 1:2 slope originating at a height of 0.05D above the helideck surface and extending out to 0.83D from the centre of the D-circle (i.e. a further 0.21D from the edge of the first segment of the LOS).

NOTE: The exact point of origin of the LOS is assumed to be at the periphery of the D-circle.

3.27 Some helidecks are able to accommodate a landing area which covers a larger area than the declared D-value; a simple example being a rectangular deck with the minor dimension able to contain the D-circle. In such cases it is important to ensure that the origin of the LOS (and OFS) is at the perimeter of the landing area as marked by the perimeter line. Any landing area perimeter should guarantee the obstacle protection afforded by both segments of the LOS. The respective measurements of 0.12D from the landing area perimeter line plus a further 0.21D are to be applied. On these larger decks there is thus some flexibility in deciding the position of the perimeter line and landing area in order to meet the LOS requirements and when considering the position and height of fixed obstacles. Separating the origin of the LOS from the perimeter of the D-circle in Figure 1 and moving it to the right of the page will demonstrate how this might apply on a rectangular-shaped landing area.

Figure 1: Obstacle limitation (single main rotor and side by side main rotor helicopters) showing position of touchdown/positioning marking circle

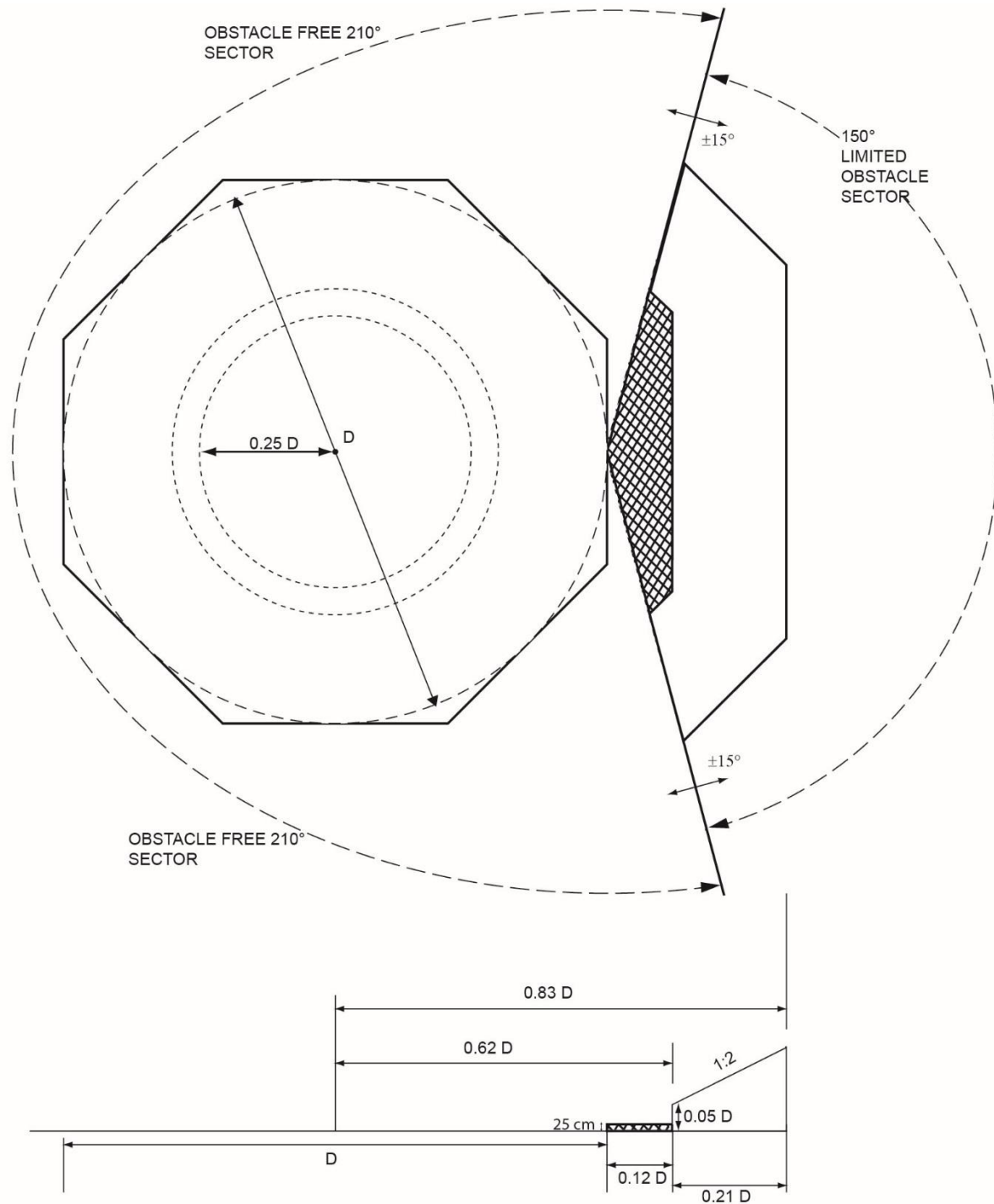

NOTE: Where the D-value is 16.00 m or less, objects in the first segment of the LOS are restricted to 5 cm.

3.28 The extent of the LOS segments will, in all cases, be lines parallel to the landing area perimeter line and follow the boundaries of the landing area

perimeter (see Figure 1). Only in cases where the perimeter of the landing area is circular will the extent of the LOS be in the form of arcs to the D-circle. However, taking the example of an octagonal landing area as drawn at Figure 1, it would be possible to replace the angled corners of the two LOS segments with arcs of $0.12D$ and $0.33D$ centred on the two adjacent corners of the landing area, thus cutting off the angled corners of the LOS segments. If these arcs are applied they should not extend beyond the two corners of each LOS segment so that minimum clearances of $0.12D$ and $0.33D$ from the corners of the landing area are maintained. Similar geometric construction may be made to a square or rectangular landing area but care should be taken to ensure that the LOS protected surfaces minima can be satisfied from all points on the inboard perimeter of the landing area.

- 3.29 For new build helideck designs the minimum landing area size should accommodate a circle encompassed by the outer edge of perimeter marking of at least $1D$ (see paragraph 3.26). However, from time-to-time new helicopter types may be introduced to the UKCS which were not in operational use when an existing helideck was designed. In this case there is a mechanism to review operations by larger (and usually heavier) helicopters than were specified in the original design for the helideck, when subject to a thorough risk assessment. The framework for a risk assessment process for helicopter operations to helidecks on the UKCS, which are sub- $1D$, is reproduced at Appendix H and may be used by a helicopter operator to present a case for sub- $1D$ operations to the CAA.
- 3.30 Whilst application of the criteria in paragraph 3.23 will ensure that no unacceptable obstructions exist above the helicopter landing area level over the whole 210° sector, it is necessary to consider the possibility of helicopter loss of height due to a power unit failure during the latter stages of the approach or early stages of take-off. Accordingly, a clear zone should be provided below landing area level on all fixed and mobile installations between the helideck and the sea. The falling 5:1 gradient should be at least 180° with an origin at the centre of the D-circle and

ideally it should cover the whole of the 210° OFS. It should extend outwards for a distance that will allow for safe clearance from obstacles below the helideck in the event of an engine failure for the type of helicopter the helideck is intended to serve. (See also Glossary of Terms and Abbreviations.) For helicopters operated in Performance Class 1 or 2 the horizontal extent of this distance from the helideck will be based upon the one-engine inoperative capability of the helicopter type to be used (see Figure 2). All objects that are underneath anticipated final approach and take-off paths should be assessed.

NOTE 1: For practical purposes the falling obstacle limitation surface can be assumed to be defined from points on the outboard edge of the helideck perimeter safety netting supports (not less than 1.5 metres from deck edge). Minor infringements of the surface by foam monitor platforms or access/escape routes may be accepted only if they are essential to the safe operation of the helideck but may also attract helicopter operational limitations.

NOTE 2: Research completed in 1999 (see Appendix B references) demonstrated that, following a single engine failure in a twin engine helicopter after take-off decision point, and assuming avoidance of the deck edge, the resulting trajectory will carry the helicopter clear of any obstruction in the range 2:1 to 3:1. It is therefore only necessary for operators to account for performance in relation to specified 5:1 falling gradient when infringements occur to a falling 3:1 rather than a 5:1 slope.

Figure 2: Obstacle free areas - Below landing area level (for all types of helicopters)

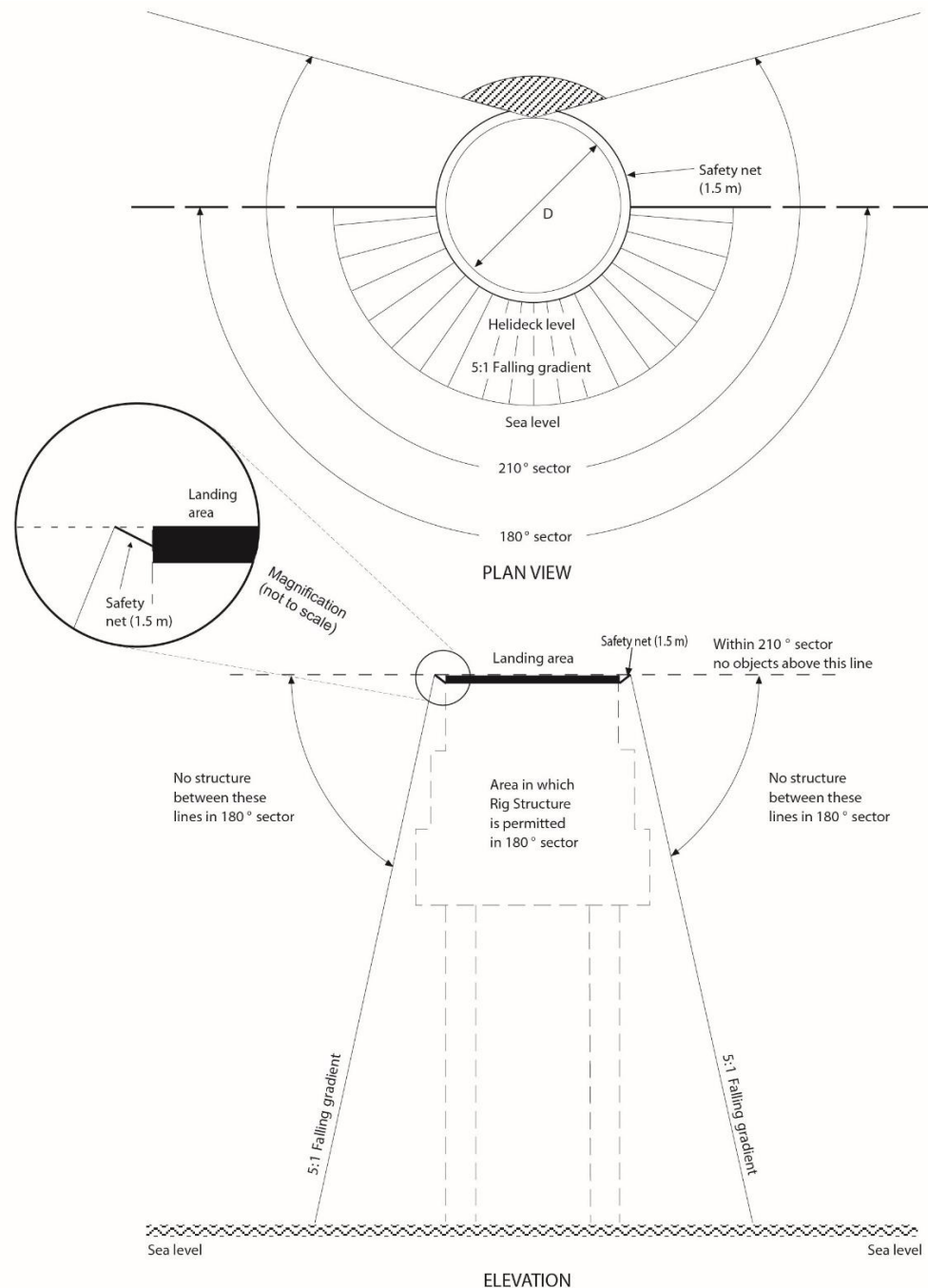

Temporary combined operations

3.31 Temporary Combined Operations are essentially arrangements where two or more offshore installations, whether fixed or floating, are in close proximity 'alongside' or 'pulled away' from one another. They may be in place for a matter of hours, days, months or for up to several years. On

occasions, combined operations may include vessels working alongside one or more fixed and/or floating installations. The close proximity of installations and/or vessels one to another is likely to entail that one or more of the landing areas becomes operationally restricted due to obstacle protected surfaces being compromised and/or due to adverse environmental effects.

3.32 So, for example, the installation pictured in the centre of Figure 3 has obstacle protected sectors and surfaces (the extended OFSs as well as the falling gradient) that are severely compromised by the proximity of the other two installations. In these circumstances a landing prohibited marker (a yellow cross on a red background) is placed on the drilling facility (centre) to prevent operations to the helideck. Where temporary combined operations are planned, a helicopter operator assessment should be completed to review the physical, as well as the environmental, impact of the arrangements and to assess whether any flight restrictions or limitations, including prohibitions, should be disseminated to air crews. All helicopter landing areas which are determined to be 'unavailable' should display the relevant landing prohibited marker by day while, by day and night, the perimeter lights should be displayed but all other helideck lighting systems (circle/H lighting and/or helideck floodlights) should be extinguished.

3.33 Combined operations usually involve both installations and/or vessels being in close proximity 'alongside' one another (as pictured), where the effect of one facility on the obstacle protected surfaces of another is immediately obvious. However, during the life of a combined arrangement there may also be periods when mobile installations and/or vessels are 'pulled-away' to a stand-off position, which could entail them being some distance apart. It is necessary for helicopter operators to re-appraise the situation for combined operations now in the 'stand-off' configuration as with one or more installations or vessels 'pulled-away' there may then be opportunity to relax or remove limitations otherwise imposed for the 'alongside' configuration.

Figure 3: A temporary combined operation showing relative position of each helideck 21⁰ sector



Multiple platform configurations/location of standby vessels

- 3.34 Where two or more fixed structures are permanently bridge-linked the overall design should ensure that the sectors and surfaces provided for the helicopter landing area(s) are not compromised by other modules which may form part of the multiple platform configurations. It is also important to assess the environmental effect of each module on the flying environment around the helideck.

- 3.35 Where there is an intention to add new modules to an existing platform arrangement it is important to make an assessment on the potential impact that additional modules may have on helideck operations. This will include an assessment of the sectors and surfaces for the helideck which should not be compromised due to the location of a new module, or modification to an existing module. This will include a detailed analysis of the environmental impact on the flying environment around the helideck (e.g. using CFD).
- 3.36 Where there is a requirement to position, at sea surface level, offshore support vessels (e.g. a Standby Vessel or tanker) essential to the operation of a fixed or floating offshore installation located within the proximity of the fixed or floating installation's obstacle free sector (OFS), but below helideck level, care should be taken to ensure offshore support vessels are not positioned to compromise the safety of helicopter operations during take-off, departure and approach to landing.

Surface

- NOTE:** Where a helideck is constructed in the form of a grating, e.g. where a passive fire retarding system is selected (see Chapter 5), the design of the helideck should ensure that ground effect is not reduced.
- 3.37 The landing area should present a non-slip surface for helicopter operations. The installation operator should ensure that the helideck is kept free from oil, grease, ice, snow, excessive surface water or any other contaminant (particularly guano) that could degrade the surface friction. Assurance should be provided to the helicopter operator that procedures are in place for elimination and removal of contaminants prior to helicopter movements.
- 3.38 The minimum average surface friction values that should be achieved are detailed in Table 2. The average surface friction values should be confirmed using a test method acceptable to the CAA – see paragraphs 3.39, 3.40 and 3.41.

Table 2: Friction requirements

Section of helideck	Fixed helideck	Moving helideck
Inside TD/PM circle	0.6	0.65
TD/PM circle and H painted markings	0.6	0.65
Outside TD/PM circle	0.5	0.5

3.39 For flat helidecks with a micro-texture finish (e.g. non-slip paint or grit-blasted finish), the helideck friction test method should normally comprise the following:

- a survey of the entire helideck surface in two orthogonal directions to a resolution of not less than 1 m²;
- use of a tester employing the braked wheel technique and a tyre made of the same material as helicopter tyres;
- testing in the wet condition using a tester that is capable of controlling the wetness of the deck during testing, and
- use of a tester which provides electronic data collection, storage and processing.

An example test protocol based on the use of the Findlay Irvine MicroGT is presented in Appendix K.

NOTE 1: No two adjacent 1 m squares should achieve less than the average surface friction value specified in paragraph 3.38 above.

NOTE 2: Where TD/PM circle and 'H' lighting is installed, testing of the TD/PM circle and 'H' painted markings is not required.

3.40 The helideck should be re-tested annually or when the condition of the deck suggests more frequent testing is appropriate, e.g. build-up of guano or other contaminant(s).

3.41 For profiled helideck surfaces, typically constructed from extruded aluminium planks, a specimen should be submitted to a suitably qualified and independent test facility for testing at full scale. The testing should normally comprise the following:

- use of a representative helicopter wheel and tyre with a tyre contact area of at least 200 cm²;
- testing at a vertical load to produce a tyre contact pressure of at least 0.95 N/mm² and ideally 1 N/mm², and also within the normal range of loads and tyre pressures for the aircraft wheel being used for the testing;
- testing in the wet condition;
- testing in all four permutations of wheel and surface profiling directions, i.e. wheel in rolling (R) and non-rolling (N) directions, along, i.e. longitudinal (L), and across, i.e. transverse (T), the ridges of the profiling to give the four test conditions of RL, RT, NL and NT;
- at least three test runs to be performed for each test condition;
- the result for each test run should be the average surface friction value for the run, excluding the initial peak due to static friction;
- the result for each test condition should be the average of the (at least three) test runs for that condition;
- the overall result for the helideck specimen should be the lowest of the results for the four conditions.

NOTE 1: Each test run may be performed using a 'fresh', undamaged section of the test tyre.

NOTE 2: For the area outside the TD/PM Circle, an inadequate surface friction value (i.e. < 0.5) may be rectified by grit blasting or by applying a suitable non-slip paint coating. For the area inside the TD/PM Circle (< 0.6 for fixed helidecks, < 0.65 for moving helidecks), removal of the profiling prior to grit blasting or painting is recommended or, alternatively, the fitment of a helideck net – see paragraph 3.42 below.

NOTE 3: The testing described in this paragraph represents a once-off type approval and no further in-service monitoring or testing is required unless the helideck has to be provided with a micro-texture finish in order to meet the minimum surface friction values required. In that case, the in-service monitoring/testing protocol specified in paragraph 3.39 should be applied with the friction tester to be used being calibrated using the full scale test results. The calibration should comprise multiplying the friction tester readings using the following scaling factor:

$$\text{Scaling factor} = \frac{\text{sum of RL + RT test condition full scale results}}{\text{sum of L + T average friction tester results}}$$

NOTE 4: Providing a lasting non-slip paint finish to the tops of ribs can be challenging. Grit blasted micro-texture finishes are likely to be more effective and more durable than non-slip paint finishes on profiled helideck surfaces.

3.42 For the area that encompasses the TD/PM Circle only, a helideck net may be used to mitigate for insufficient surface friction provided that the average surface friction value is at least 0.5. The net should be installed and tensioned in accordance with the manufacturer's instructions and should have the following properties:

- the mesh size should be such as to present an area of between 400 and 900 cm²;
- the net should be secured at intervals approximately 1.5 metres between the lashing points around the landing area perimeter;
- the breaking strain of the rope/webbing from which the net is constructed and the load capacity of the net anchoring points should be at least 10 kN;
- the size of the net should such as to ensure coverage of the TD/PM Circle area but should not cover the helideck identification marking (name) or 't' value markings.

NOTE 1: Helideck nets are incompatible with helicopters fitted with skid undercarriages and should not be used where the operation of such aircraft is to take place.

NOTE 2: It should be borne in mind when selecting a helideck net that the height of the netting (i.e. the thickness of the installed net including knots) should be in accordance with the requirements specified in paragraph 3.23.

NOTE 3: The helideck net may be any shape but should cover the whole of the TD/PM circle, but not be so large as to obscure other essential markings e.g. helideck name marking, maximum allowable mass marking. The net should be constructed from durable materials not prone to flaking due to prolonged exposure to the weather (e.g. UV light), or to the elements (e.g. salt water).

NOTE 4: If a helideck net is to be fitted, measures should be taken to ensure that:

- the performance of TD/PM Circle and 'H' lighting is not impaired. This will be especially evident at low angles (i.e. less than 6 degrees) of elevation;
- the net does not impair the operation of automatic fire-fighting system 'pop-up' nozzles, where fitted, or otherwise compromise the fire fighting facilities.

3.43 In addition to paragraph 3.42 above, it will normally be necessary to install helideck nets on Normally Unattended Installations (NUIs) where it is impractical to guarantee that the helideck will remain clear of contaminants such that there is no risk of helideck markings and visual cues being compromised or friction properties reduced. It is recommended that the design of new installations should incorporate the provision of helideck net fittings regardless of the type of friction surface to be provided.

3.44 Every landing area should be equipped with adequate surface drainage arrangements and a free-flowing collection system that will quickly and safely direct any rainwater and/or fuel spillage and/or fire fighting media away from the helideck surface to a safe place. Helidecks on fixed installations should be cambered (or laid to a fall) to approximately 1:100. Any distortion of the helideck surface on an installation due to, for example, loads from a helicopter at rest should not modify the landing area drainage system to the extent of allowing spilled fuel to remain on the deck. A system of guttering on a new-build or a slightly raised kerb should be provided around the perimeter to prevent spilled fuel from falling on to other parts of the installation and to conduct the spillage to an appropriate drainage system. The capacity of the drainage system should be sufficient to contain the maximum likely spillage of fuel on the helideck. The calculation of the amount of spillage to be contained should be based on an analysis of helicopter type, fuel capacity, typical fuel loads and uplifts. The design of the drainage system should preclude blockage by debris which is best achieved by use of a mesh type filtration system able

to strain out smaller items of debris. The helideck area should be properly sealed so that spillage will only route into the drainage system.

Helicopter tie-down points

3.45 Sufficient flush fitting (when not in use) tie-down points should be provided for securing the maximum sized helicopter for which the helideck is designed. They should be so located and be of such strength and construction to secure the helicopter when subjected to weather conditions pertinent to the installation design considerations. They should also take into account, where significant, the inertial forces resulting from the movement of floating units.

Figure 4: Example of suitable tie-down configuration

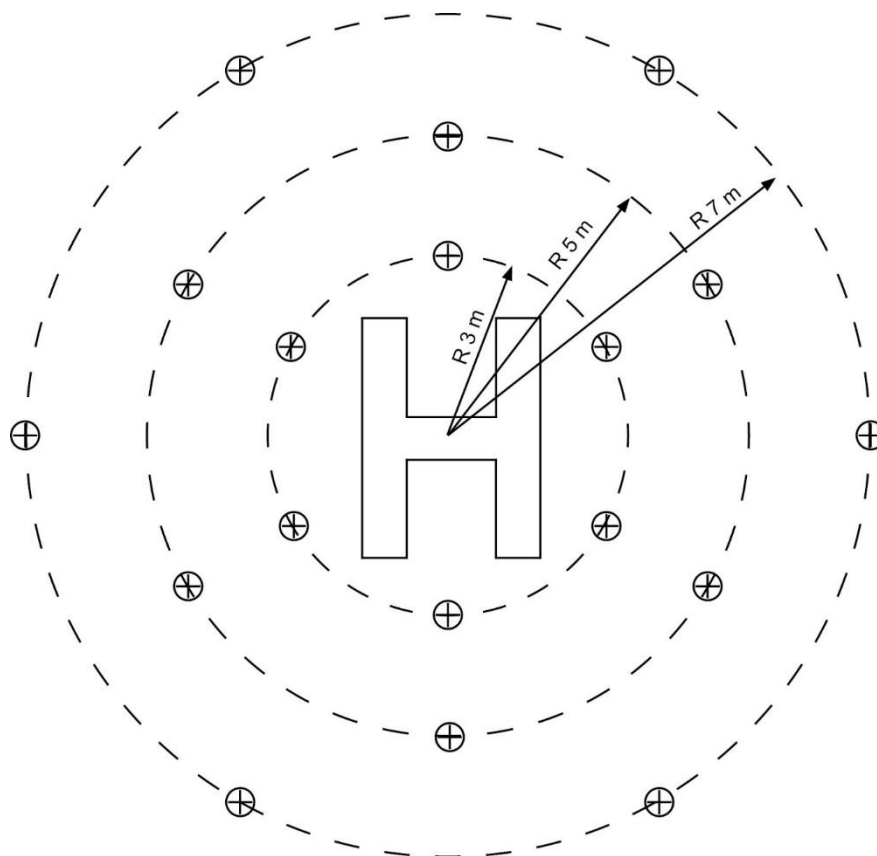

NOTE 1: The tie-down configuration should be based on the centre of the TD/PM Circle.

NOTE 2: Additional tie-downs will be required in a parking area.

NOTE 3: The outer circle is not required for D-values of less than 22.2 m.

- 3.46 Tie-down strops held on the installation or vessel should be compatible with the bar diameter of the helideck tie-down points. Tie-down points and strops should be of such strength and construction so as to secure the helicopter when subjected to weather conditions pertinent to the installation design considerations. The maximum bar diameter of the tie-down point should be 22 mm in order to match the strop hook dimension of typical tie-down strops. Advice on recommended safe working load requirements for strop/ring arrangements for specific helicopter types can be obtained from the helicopter operator.
- 3.47 An example of a suitable tie-down configuration is shown at Figure 4. The agency responsible for the certification of the helideck should be able to provide guidance on the configuration of the tie-down points for specific helicopter types.

Perimeter safety net

- 3.48 Safety nets for personnel protection should be installed around the landing area except where adequate structural protection against a fall exists. The netting used should be of a flexible nature, with the inboard edge fastened just below the edge of the helicopter landing deck. The net itself should extend at least 1.5 metres, but no more than 2.0 metres, in the horizontal plane and be arranged so that the outboard edge does not exceed the level of the landing area and angled so that it has an upward and outward slope of approximately 10°.
- 3.49 A safety net designed to meet these criteria should 'contain' personnel falling into it and not act as a trampoline. Where lateral or longitudinal centre bars are provided to strengthen the net structure they should be arranged and constructed to avoid causing serious injury to persons falling on to them. The ideal design should produce a 'hammock' effect which should securely contain a body falling, rolling or jumping into it, without serious injury. When considering the securing of the net to the structure and the materials used, care should be taken that each segment

will be fit for purpose. Various wire meshes have been shown to be suitable if properly installed.

NOTE 1: It is not within the scope or purpose of CAP 437 to provide detailed advice for the design, fabrication and testing of helideck perimeter nets. Given the responsibility rests with the duty holder to ensure the net is fit for purpose, and is subjected to a satisfactory inspection and testing regime, specific issues are addressed in the Oil and Gas UK 'Aviation Operations Management Standards and Guidelines'.

NOTE 2: Perimeter nets may incorporate a hinge arrangement to facilitate the removal of sacrificial panels for testing.

NOTE 3: Perimeter nets that extend up to 2.0 m in the horizontal plane, measured from the edge of the landing area, will not normally attract operational limitations.

Access points

3.50 For reasons of safety it is necessary to ensure that embarking and disembarking passengers are not required to pass around the helicopter tail rotor, or around the nose of helicopters having a low profile main rotor, when a 'rotors-running turn-round' is conducted (in accordance with normal offshore operating procedures). Many helicopters have passenger access on one side only and helicopter landing orientation in relation to landing area access points is therefore very important.

3.51 There should be a minimum of two access/egress routes to the helideck. The arrangements should be optimised to ensure that, in the event of an accident or incident on the helideck, personnel will be able to escape upwind of the landing area. Adequacy of the emergency escape arrangements from the helideck should be included in any evacuation, escape and rescue analysis for the installation, and may require a third escape route to be provided.

3.52 The need to preserve, in so far as possible, an unobstructed falling 5:1 gradient (see paragraph 3.30 and Figure 2) and the provision of up to three helideck access/escape routes, with associated platforms, may

present a conflict of requirements. A compromise may therefore be required between the size of the platform commensurate with its effectiveness and the need to retain the protection of an unobstructed falling 5:1 gradient. In practice, the 5:1 gradient is taken from the outboard edge of the helideck perimeter safety net supports. Emergency access points which extend outboard from the perimeter safety net constitute a compromise in relation to an unobstructed falling 5:1 gradient which may lead, in some instances, to the imposition of helicopter operating limitations. It is therefore important to construct access point platforms in such a manner as to infringe the falling 5:1 gradient by the smallest possible amount but preferably not at all. Suitable positioning of two major access points clear of the requirements of the protection of the falling 5:1 gradient should be possible. However, the third access referred to at paragraph 10.2 will probably lie within the falling 5:1 sector and where this is the case it should be constructed within the dimensions of the helideck perimeter safety net supports (i.e. contained within a horizontal distance of 1.5 - 2.0 m measured from the edge of the landing area).

- 3.53 Where foam monitors are co-located with access points care should be taken to ensure that no monitor is so close to an access point as to cause injury to escaping personnel by operation of the monitor in an emergency situation.
- 3.54 Where handrails associated with helideck access/escape points exceed the height limitations given at paragraph 3.23 they should be retractable, collapsible or removable. When retracted, collapsed or removed the rails should not impede access/egress or lead to gaps which could result in a potential fall from height. Handrails which are retractable, collapsible and removable should be painted in a contrasting colour scheme. Procedures should be in place to retract, collapse or remove them prior to helicopter arrival. Once the helicopter has landed, and the crew have indicated that passenger movement may commence (see Note below), the handrails may be raised and locked in position. The handrails should be retracted, collapsed or removed again prior to the helicopter taking off.

NOTE: The helicopter crew will switch off the anti-collision lights to indicate that the movement of passengers and/or freight may take place (under the control of the HLO). Installation/vessel safety notices placed on approach to the helideck access should advise personnel not to approach the helicopter when the anti-collision lights are on.

Winching (hoist) operations

3.55 Except for operations to Wind Turbine Generators (WTGs) – see Chapter 10, paragraph 10.14 – for any other installation or vessel, attended or unattended, fixed or mobile for which helicopters are a normal mode of transport for personnel, a helicopter landing area should be provided. Winching should not be adopted as a normal method of transfer except to WTGs. However, in cases where heli-hoist operations are required, they should be conducted in accordance with procedures agreed between the helicopter operator and the CAA and contained within the helicopter operator's Operations Manual. Requirements for winching operations should be discussed with the specific helicopter operator well in advance. Winching area design arrangements are described in more detail in Chapter 10.

Normally Unattended Installations (NUIs)

- 3.56 The CAA has in the past provided guidance for helicopter operators on the routeing of helicopters intending to land on NUIs. CAA Flight Operations (Helicopters) is able to provide guidance and advice to helicopter operators in consideration of specific safety cases and risk analyses intended to address routeing philosophy.
- 3.57 Guano and associated bird debris is a major problem for NUIs. Associated problems concern the health hazard on board; degradation of visual aids (markings and lighting) and friction surfaces; and the potential for Foreign Object Debris/Damage (FOD). Helicopter operators should continuously monitor the condition of NUI helidecks and advise the owner/operator before marking and lighting degradation becomes a safety concern. Experience has shown that, unless adequate cleaning operations are

undertaken or effective preventative measures are in place, essential visual aids will quickly become obliterated. NUIs should be monitored continuously for signs of degradation of visual cues and flights should not be undertaken to helidecks where essential visual cues for landing are insufficient.

- 3.58 Guano is an extremely effective destroyer of friction surfaces whenever it is allowed to remain. Because of the difficulty of ensuring that a friction surface is kept clear of contaminants (see paragraph 3.37), permanent removal of the landing net on NUIs is not normally a viable option unless effective preventative measures are in place.

Criteria for parking areas

- 3.59 The ability to park a helicopter on an offshore installation or vessel and still be able to use the landing area for other helicopter operations provides greater operational flexibility. A parking area, where provided, should be located within the 150 degree limited obstacle sector (LOS) and equipped with markings to provide effective visual cues to assist flight crews positioning helicopters on the parking area.
- 3.60 It is therefore necessary for a parking area to be clearly distinguishable from the landing area. By day this is achieved by ensuring a good contrast between the surface markings of the landing area and the surface markings of the parking area. For a standard dark green helideck, a parking area painted in a light grey colour utilising a high friction coating, will provide suitable contrast.
- 3.61 The dimensions of the parking area should be able to accommodate a circle with a minimum diameter of $1 \times D$ for the design helicopter. A minimum clearance between the edge of the parking area and the edge of the landing area of $1/3$ ($0.33D$) based on the design helicopter should be provided. The $0.33D$ clearance area represents the parking transition area (PTA) — and should be kept free of obstacles when a helicopter is located in the parking area. Figure 5 defines the basic scheme for a $1D$ landing area with associated $1D$ parking area. The thickness of the parking area

positioning marking circle should be 1m while the yellow lead-in line from the PTA to the parking area should be at-least 0.5m. “PARKING AREA” should be painted inside the yellow circle using characters no less than 1.5m in height.

Figure 5: General arrangement - 1D helicopter landing area with associated 1D parking area separated by a parking transition areas (PTA)

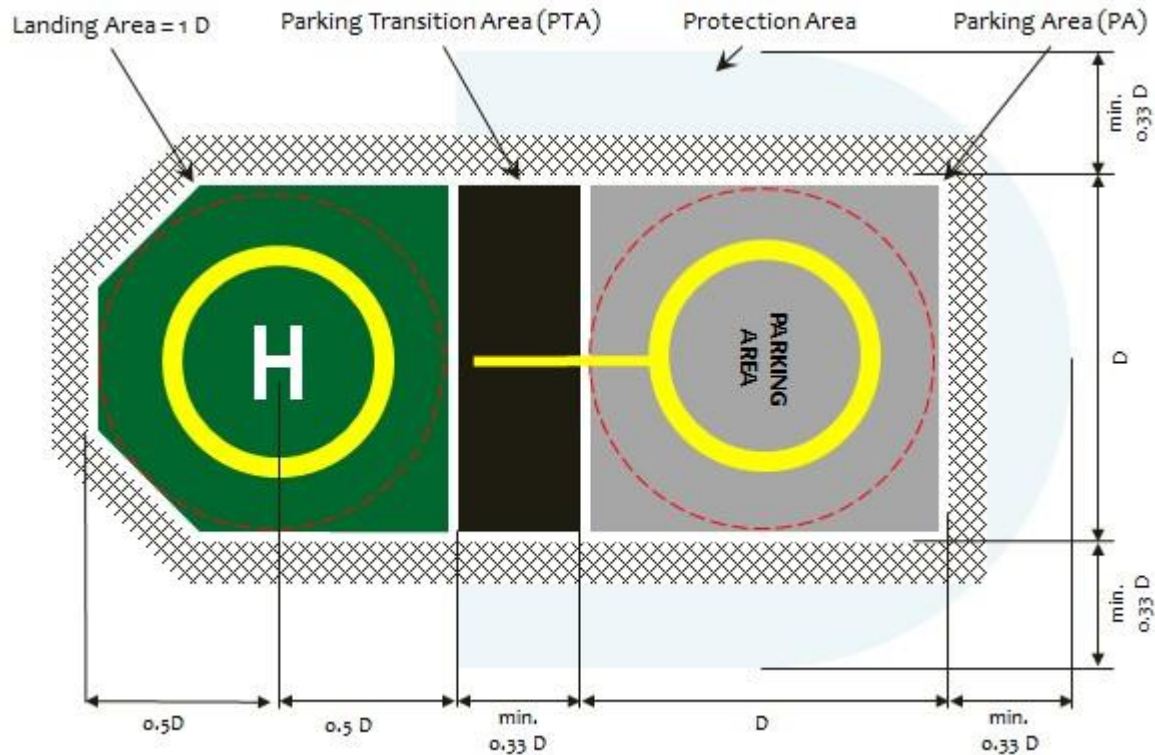

- 3.62 To provide illumination for the parking area at night, and to ensure a pilot is able to differentiate between the parking area and the landing area, it is recommended that blue parking area perimeter lights are provided; the colour green should be avoided for the parking area and the associated PTA. As the perimeter lights around the parking area do not need to be viewed at range, unlike the landing area perimeter lights, the parking area perimeter lights may be a low intensity light — no less than 5 candelas at any angle of elevation (and subject to a maximum of 60 cds at any angle). A typical parking area lighting scheme is illustrated at Figure 6.

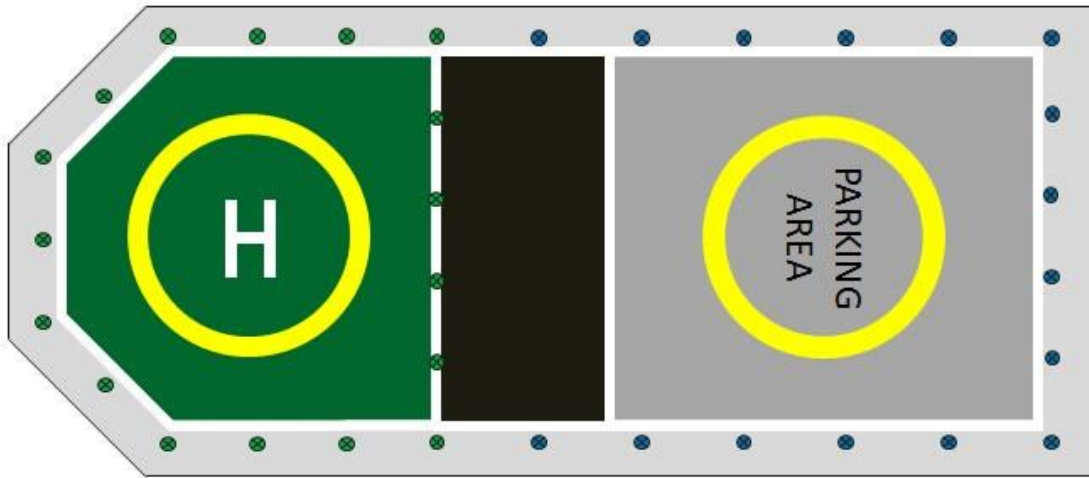
Figure 6: Illustration of landing and parking area deck lighting scheme

NOTE: Consistent with the arrangements for the landing area, provisions should be put in place for parking/parking transition areas to ensure adequate surface drainage arrangements and a skid-resistant surface for helicopters and persons operating on them. When tying down helicopters in the parking area it is prudent to ensure sufficient tie-down points are located about the touchdown/positioning marking circle. A safety device, whether netting or shelving, should be located around the perimeter of the parking area and the parking transition area. Parking areas may be provided with one or more access points to allow personnel to move to and from the parking area without having to pass through the parking transition area to the landing area. Consideration will need to be given to fire fighting arrangements for the parking area and PTA. The structural design requirements applied to a parking area and PTA should not be less than the loads for helicopters at rest (see paragraph 3.21).

Chapter 4

Visual aids

General

- 4.1 The name of the installation should be clearly displayed in such positions on the installation so that it can be readily identified from the air and sea from all normal angles and directions of approach. For identification from the air the helideck name and the side identification panels are used. It is not necessary, nor is it a legal requirement, to complicate recognition processes by inclusion of 'block numbers', company logos, or other designators. In fact, complication of identifiers can be confusing and will unnecessarily, and undesirably, extend the mental process of recognition at the critical time when the pilots' concentration is being fully exercised by the demands of the landing manoeuvre. The names on both identification markings should be identical, simple and unique and facilitate unambiguous communication via radio. The approved radio callsign of the installation should be the same name as painted on the helideck and displayed on the side panel identifier. Where the inclusion of 'block numbers' on side identification panels is deemed to be essential (i.e. for purposes other than recognition), the name of the installation should also be included; e.g. 'NAME. BLOCK NO.' The installation identification panels should be highly visible in all light conditions and from all directions of approach. They should be suitably illuminated at night and in conditions of poor visibility. In order to minimise the possibility of 'wrong rig landings' use of new technology is encouraged so that identification can be confirmed in the early stages of the approach by day and night. Modern technology is capable of meeting this requirement in most ambient lighting conditions. Use of high-intensity Light Emitting Diode (LED) cluster or fibre-optic systems in other applications have been shown to be effective even in severely reduced visibility. Additionally, it is recognised that alternative technologies have been developed consisting

of highly visible reflective side signage that has been successfully installed on some installations with the co-operation of the helicopter operator. (HSE Operations Notice 39, re-issued in June 2008, provides 'Guidance on Identification of Offshore Installations'.)

- 4.2 Helideck markings (specifically the installation identification marking) and side identification panels are used by pilots to obtain a final pre-landing confirmation that the correct helideck is being approached. It is therefore **VITAL** that the helideck markings and side identification panels are maintained in the best possible condition, regularly re-painted and kept free of all visibility-reducing contaminants. Helideck owners/operators should ensure that specific inspection and re-painting maintenance procedures and schedules for helideck markings and side identification panels take account of the importance of their purpose. Side identification panels should be kept free of any obscuring paraphernalia (draped hoses etc.) and be as high as possible on the structure.
- 4.3 The installation identification (see paragraphs 4.1 and 4.2) should be marked in white characters on the helideck surface between the origin of the OFS and the TD/PM Circle in symbols not less than 1.2 metres where a helideck is below 16.0m. For all helidecks 16.0m and greater, whether new builds or at the next scheduled repaint, the character height should be increased to 1.5m in white which contrasts with the helideck surface. The name should not be obscured by the deck net (where fitted). For an unpainted aluminium surface the installation identification (in white characters) should be displayed against a black background.
- 4.4 Helideck perimeter line marking and lighting serves to identify the limits of the Landing Area (see Glossary) for day and night operations respectively.
- 4.5 A wind direction indicator (windsock) should be provided and located so as to indicate the free stream wind conditions at the installation/vessel location. It is often inappropriate to locate the primary windsock as close to the helideck as possible where it may compromise obstacle protected

surfaces, create its own dominant obstacle or be subjected to the effects of turbulence from structures resulting in an unclear wind indication. The windsock should be illuminated for night operations. Some installations may benefit from a second windsock to indicate a specific difference between the local wind over the helideck and the free stream wind.

- 4.6 For character marking dimensions, where character bar width is not specified, use 15% of character height with 10% of character height between characters (extreme right-hand edge of one character to extreme left-hand edge of next character) and approximately 50% of character height between words. Wherever practical it is recommended that Clearview Hwy 5-W font is used.

Helideck landing area markings

- 4.7 The colour of the helideck should be dark green. The perimeter of the landing area should be clearly marked with a white painted line 30 cm wide (see Figure 1). Nonslip materials should be used.

Figure 1: Markings (single main rotor helicopters)

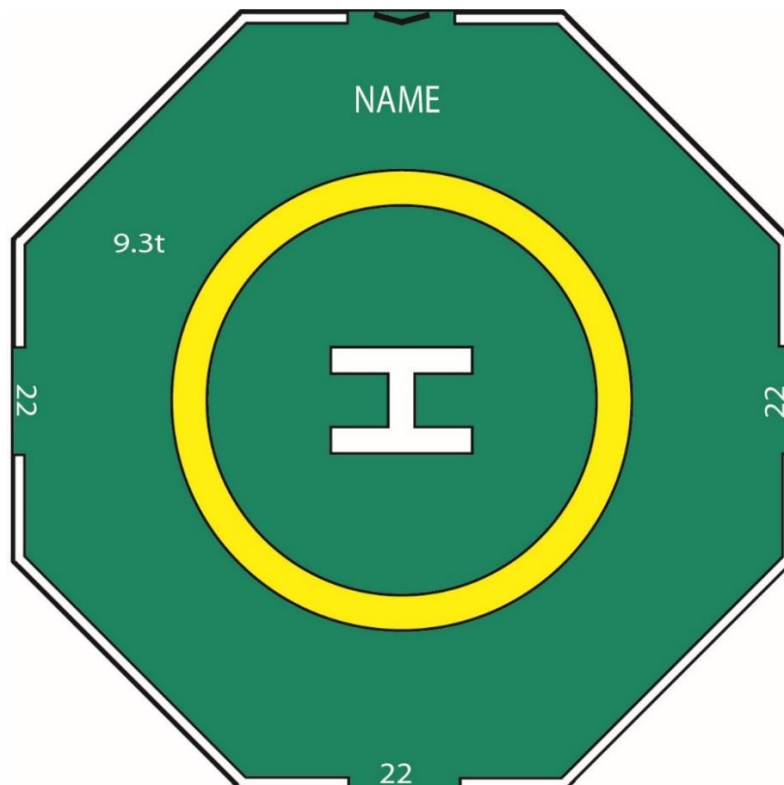

- 4.8 Aluminium helidecks are in use throughout the offshore industry. Some of these are a natural light grey colour and may present painting difficulties. The natural light grey colour of aluminium may be acceptable in specific helideck applications where these are agreed with the agency responsible for the certification of the helideck. This should be discussed in the early design phase. In such cases the conspicuity of the helideck markings may need to be enhanced by, for example, overlaying white markings on a painted black background. Additionally, conspicuity of the yellow TD/PM Circle may be enhanced by outlining the deck marking with a thin black line (typically 10 cm).
- 4.9 The origin of the 210° OFS for approach and take-off as specified in Chapter 3 should be marked on the helideck by a black chevron, each leg being 79 cm long and 10 cm wide forming the angle in the manner shown in Figure 2. On minimum sized helidecks where there is no room to place the chevron where indicated, the chevron marking, but not the point of origin, may be displaced towards the D-circle centre. Where the OFS is swung in accordance with the provision of Chapter 3 paragraph 3.25 this should be reflected in the alignment of the chevron. The purpose of the chevron is to provide visual guidance to the HLO so that he can ensure that the 210° OFS is clear of obstructions before giving a helicopter clearance to land. The black chevron may be painted on top of the (continuous) white perimeter line to achieve maximum clarity for the helideck crew.

Figure 2: Helideck D-value and obstacle-free marking

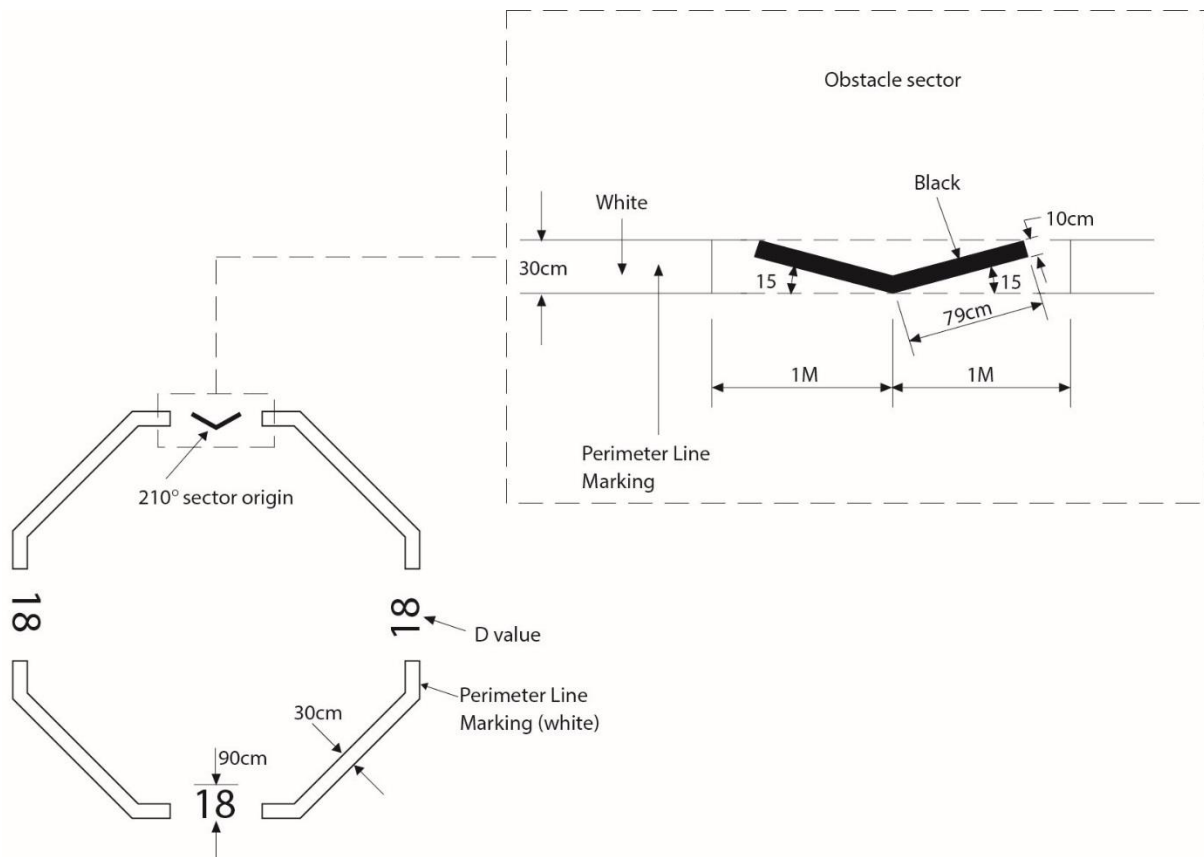

- 4.10 The actual D-value of the helideck (see Chapter 3, paragraph 3.22) should be painted on the helideck adjacent to, and where practical inboard of, the chevron in alphanumeric symbols 10 cm high. Where, for an existing installation, a helideck has been accepted which does not meet the normal minimum OFS requirements of 210°, the black chevron should represent the angle which has been accepted and this value should be marked inboard of the chevron in a similar manner to the certificated D-value. It is expected that new-builds will always comply in full with the requirement to provide a minimum 210° OFS.
- 4.11 The helideck D-value should also be marked around the perimeter of the helideck in white characters no less than 90 cm high, in the manner shown in Figures 1 and 2. The D-value should be expressed to the nearest whole number with 0.5 rounded down, e.g. 18.5 marked as 18 (see Chapter 3, Table 1). For an unpainted aluminium surface helideck D-

value(s) (in white characters) should be displayed against a black background.

NOTE: Helidecks designed specifically for AS332L2 and EC 225 helicopters, each having a D-value of 19.5 m, should be rounded up to 20 in order to differentiate between helidecks designed specifically for L1 models. For helidecks where the actual D-value is less than 15.00 m, the height of the numbers may be reduced from 90 cm to no less than 60 cm.

4.12 A maximum allowable mass marking should be marked on the helideck in a position which is readable from the preferred final approach direction, i.e. towards the OFS origin. The marking should consist of a two- or three-digit number expressed to one decimal place rounded to the nearest 100 kg and followed by the letter 't' to indicate the allowable helicopter mass in tonnes (1000 kg). The height of the figures should be 90 cm with a line width of approximately 12 cm and should be white i.e. be in a colour which contrasts with the helideck surface. For an unpainted aluminium surface a maximum allowable mass marking (in white characters) should be displayed against a black background. Where possible the mass marking should be well separated from the installation identification marking (see paragraph 4.3) in order to avoid possible confusion on recognition. Refer also to Figure 1 and Chapter 3, Table 1.

4.13 A Touchdown/Positioning Marking (TD/PM) should be provided (see Figures 1 and 3). The marking should be a yellow circle with an inner diameter of 0.5 of the certificated D-value of the helideck and a line width of 1 metre (for new build helidecks below 16m the line width may be reduced to 0.5m). The centre of the marking should be concentric with the centre of the D-circle.

Figure 3: Touchdown/Positioning marking circle (TD/PM circle to be painted yellow)

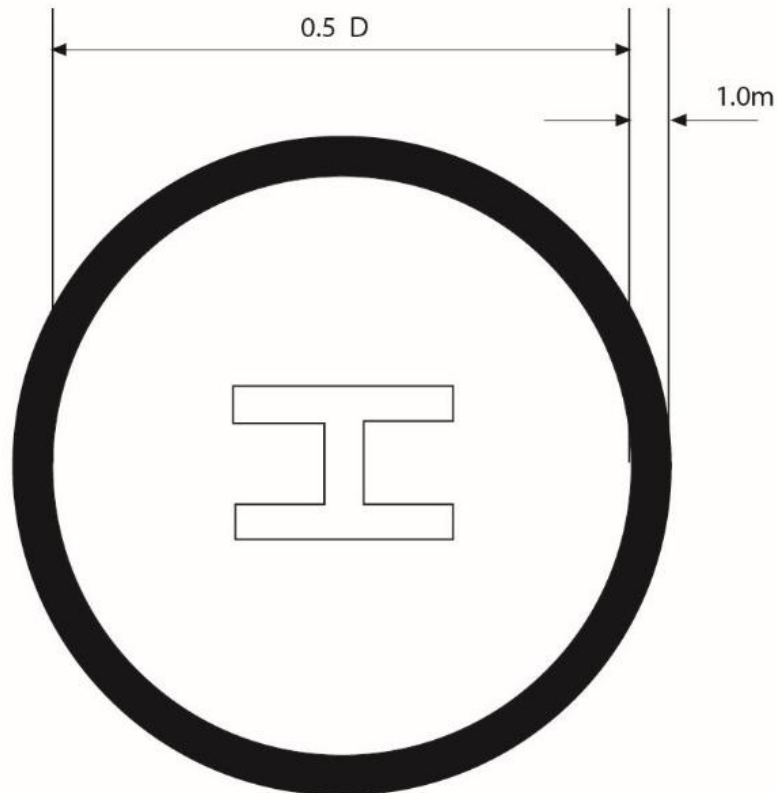

NOTE: On a helideck the centre of the TD/PM Circle will normally be located at the centre of the landing area, except that the marking may be offset away from the origin of the OFS by no more than $0.1D$ where an aeronautical study indicates such offsetting to be beneficial, provided that the offset marking does not adversely affect the safety of flight operations or ground handling issues.

4.14 A white heliport identification marking 'H' marking should be marked co-located with the TD/PM with the cross bar of the 'H' lying along the bisector of the OFS. Its dimensions are as shown in Figure 4. For new build helidecks having a D-value below 16.0m, the dimensions of the 'H' marking may be reduced to 3m x 2m x 0.5m.

Figure 4: Dimensions of heliport identification marking 'H' ('H' to be painted white)

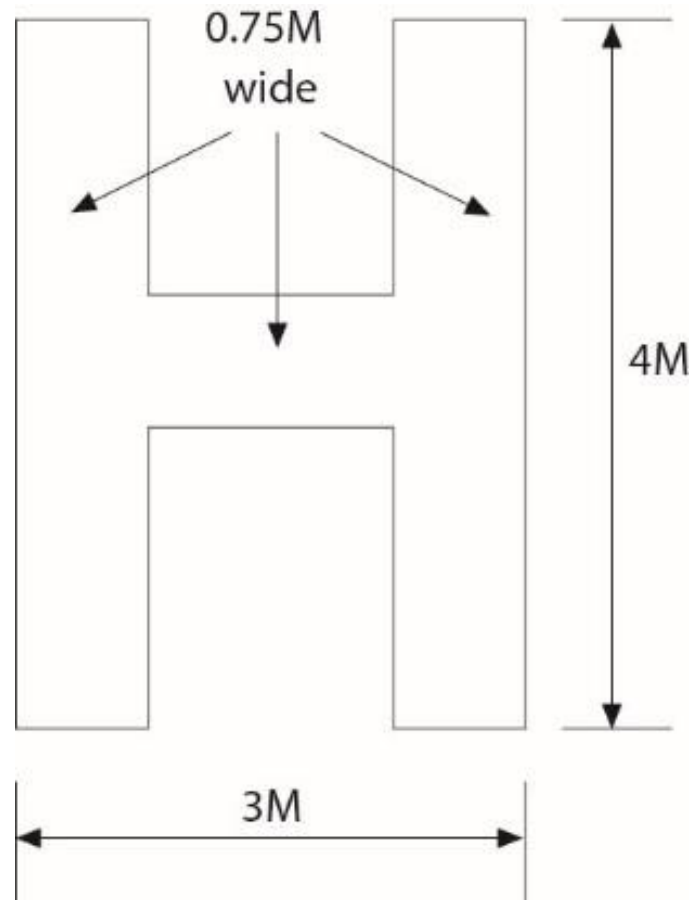

- 4.15 Where the OFS has been swung in accordance with Chapter 3 paragraph 3.25 the positioning of the TD/PM and 'H' should comply with the normal unswung criteria. However, the 'H' should be orientated so that the bar is parallel to the bisector of the swung sector.
- 4.16 Prohibited landing heading sectors should be marked where it is necessary to protect the tail of the helicopter from landing or manoeuvring in close proximity to limiting obstructions which, for example, infringe the 150° LOS protected surfaces. When required, prohibited sectors are to be shown by red hatching of the TD/PM, with white and red hatching extending from the red hatching out to the edge of the landing area as shown in Figures 5 and 6.
- NOTE:** When positioning over the TD/PM helicopters should be manoeuvred so as to keep the aircraft nose clear of the hatched prohibited sector(s) at all times.

Figure 5: Specification for the layout of prohibited landing heading segments on helidecks

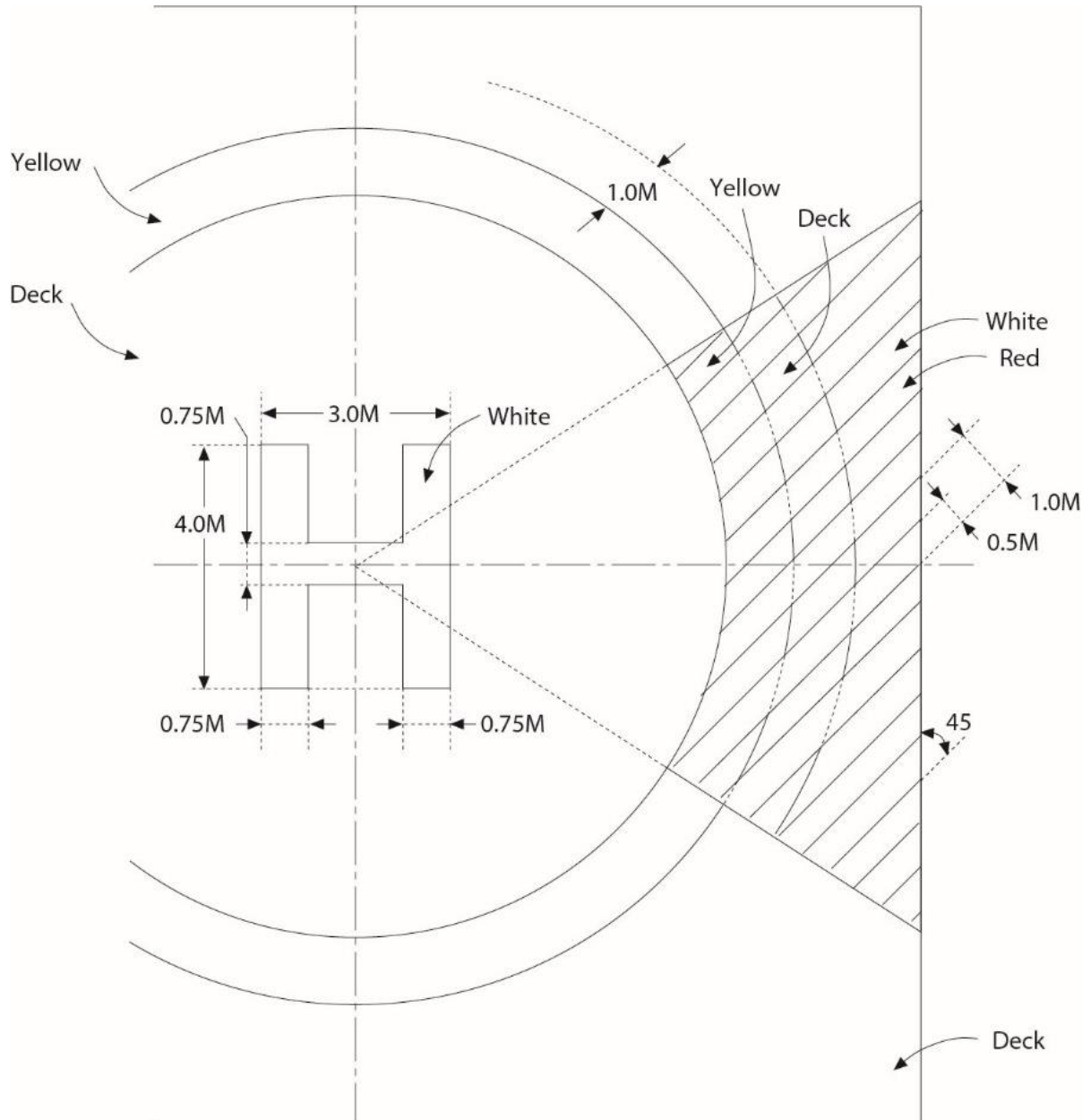

Figure 6: Example of prohibited landing heading marking



NOTE: The position of the 'H' and the orientation of the prohibited landing heading segment will depend on the obstacle.

4.17 For certain operational or technical reasons an installation may have to prohibit helicopter operations. In such circumstances, where the helideck cannot be used, the 'closed' state of the helideck should be indicated by use of the signal shown in Figure 7. This signal is the standard 'landing prohibited' signal given in the Rules of the Air and Air Traffic Control Regulations, except that it has been altered in size to just cover the letter 'H' inside the TD/PM.

Figure 7: Landing on installation/vessel prohibited

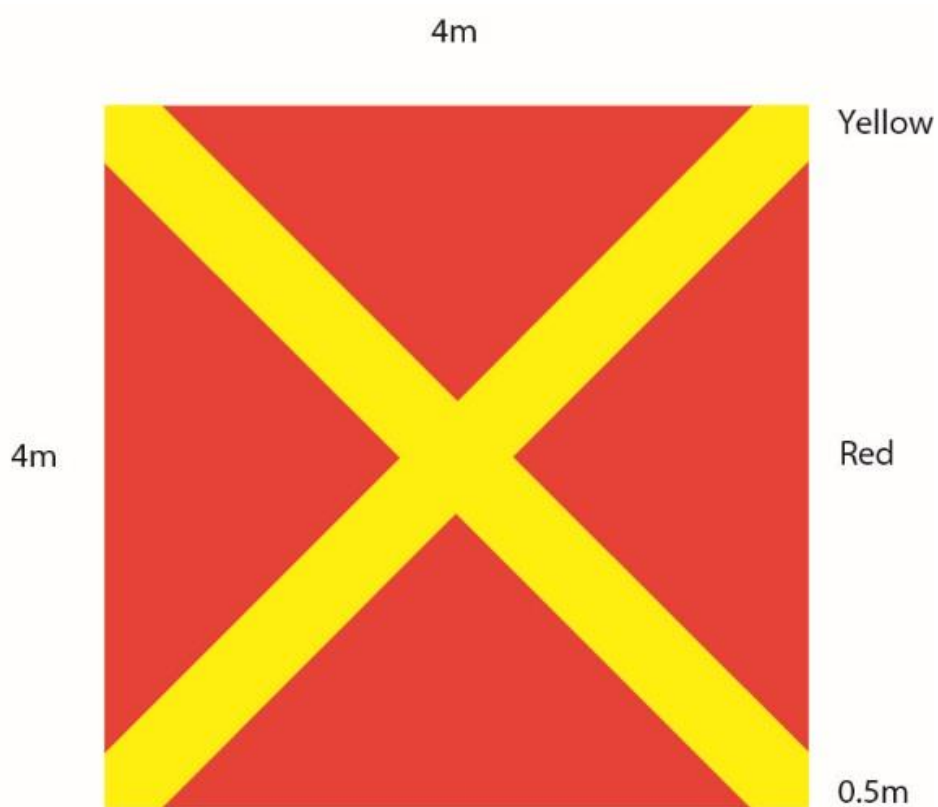

NOTE: Signal covers 'H' inside TD/PM.

4.18 Colours should conform with the following BS 381C (1996) standard or the equivalent BS 4800 colour. White should conform to the RAL charts.

- RED
BS 381C: 537 / RAL 3001 (Signal Red)
BS 4800: 04.E.53 / RAL 2002 (Poppy)
- YELLOW
BS 381C: 309 / RAL1018 (Canary Yellow)
BS 4800: 10.E.53 / RAL1023 (Sunflower Yellow)
- DARK GREEN
BS 381C: 267 / RAL 6020 (Deep Chrome Green)
BS 4800: 14.C.39 (Holly Green)
- WHITE
RAL 9010 (Pure White)
RAL 9003 (Signal White)

Lighting

NOTE 1: The paragraphs below should be read in conjunction with Appendix C which contains the specification for the full helideck lighting scheme comprising perimeter lights, lit TD/PM Circle and lit heliport identification "H" marking. The specification for each element is fully described in Appendix C with the overall operational requirement detailed in paragraph 1 of the Appendix. The helideck lighting scheme is a requirement for the conduct of night operations and is intended to provide effective visual cues for a pilot throughout the approach and landing manoeuvre at night. Starting with the initial acquisition of the helideck, the lighting needs to enable a pilot to easily locate the position of the helideck on the installation at long range on an often well lit offshore structure. The lighting should then guide the helicopter to a point above the landing area and then provide visual cues to assist with the touchdown. At night, when a helideck is not in use, and to mitigate the possibility of a 'wrong rig landing' on an unsafe helideck, the Lit Touchdown/ Positioning Marking and Lit Heliport Identification Marking and/or helideck floodlighting should be extinguished. However, green perimeter lights should remain 'on' so that the outline of the helideck can be distinguished from the air.

NOTE 2: The specification has an in-built assumption that the performance of the helideck lighting system will not be diminished by any other lighting due to the relative intensity, configuration or colour of other lighting sources on the installation or vessel. Where other non-aeronautical ground lights have the potential to cause confusion or to diminish or prevent the clear interpretation of helideck lighting systems, it will be necessary for an installation or vessel operator to extinguish, screen or otherwise modify these lights to ensure that the effectiveness of the helideck lighting system is not compromised. This will include, but may not be limited to, an assessment of the effect of general installation lighting on the performance of the helideck lighting scheme. The CAA recommends that installation and vessel operators give serious consideration to shielding high intensity light sources (e.g. by fitting screens or louvers) from helicopters approaching and landing, and maintaining a good colour contrast between the helideck lighting and surrounding installation lighting. Particular attention should be paid to the areas of the installation adjacent to the helideck.

NOTE 3: The specification contained in Appendix C includes a facility to increase the intensity of some elements of the helideck lighting to compensate for installations or vessels with high levels of background lighting. The setting of the intensity of the helideck lighting should be carried out in conjunction with the helicopter operator as a once-off exercise following installation of the lighting, and subsequently if required following changes to the lighting environment at the installation or vessel. The intensity of the helideck lighting should not be routinely changed, and in any event should not be altered without the involvement and agreement of the helicopter operator.

Perimeter lighting

- 4.19 The periphery of the landing area should be delineated by omnidirectional green perimeter lights visible from on or above the landing area; however, the pattern formed by the lights should not be visible to the pilot from below the elevation of the landing area. Perimeter lights should be mounted above the level of the helideck but should not exceed the height limitations specified in Appendix C, paragraph C.16. The lights should be equally spaced at intervals of not more than three metres around the perimeter of the landing area, coincident to or adjacent with the white line delineating the perimeter (see paragraph 4.7 above). In the case of square or rectangular decks there should be a minimum of four lights along each side including a light at each corner of the landing area. Recessed helideck perimeter lights may be used at the inboard (150° LOS origin) edge of the landing area where an operational need exists to move large items of equipment to and from the landing area, e.g. where a run-off area is provided there may be a need to move the helicopter itself to and from the landing area onto the adjacent run-off (parking) area. Care should be taken to select recessed helideck perimeter lights that will meet the iso-candela requirements stated in Appendix C, Table 2.
- 4.20 Where the declared D-value of the helideck is less than the physical helideck area, the perimeter lights should be coincidental with the white perimeter marking and black chevron and delineate the limit of the useable landing area so that, in unusual circumstances where a helicopter

touches down inboard of the TD/PM Circle, it can land safely by reference to the perimeter lights on the 150° LOS 'inboard' side of the helideck without risk of the main rotor striking obstructions in this sector. By applying the LOS clearances (given in Chapter 3, paragraphs 3.26 to 3.27) from the perimeter marking and coincident lighting, adequate main rotor to obstruction separation should be achieved for the worst-case helicopter intended to operate to the helideck.

Floodlighting, lit TD/PM circle and lit heliport identification 'H' marking

4.21 In order to aid the visual task of final approach and hover and landing it is important that adequate visual cues be provided. For use at night, this has previously been achieved using floodlighting; however, these systems can adversely affect the visual cueing environment by reducing the conspicuity of helideck perimeter lights during the approach, and by causing glare and loss of pilots' night vision during the hover and landing. Furthermore, floodlighting systems often fail to provide adequate illumination of the centre of the landing area leading to the so-called 'black-hole effect'.

4.22 A new lighting scheme comprising a lit TD/PM Circle and a lit heliport identification 'H' marking has therefore been developed and is effectively mandated for operations taking place at night on the UKCS from 1st April 2018. This scheme, described in detail in Appendix C, has been clearly demonstrated to provide the visual cues required by the pilot earlier on in the approach, and much more effectively than floodlighting and without the disadvantages associated with floodlights such as glare. The CAA has therefore replaced the traditional floodlighting systems with the new offshore helideck lighting scheme meeting the specification given in Appendix C.

NOTE 1: As a result of the G-REDU accident in February 2009, the Air Accidents Investigation Branch (AAIB) has published Air Accident Report 1/2011 which addresses a number of safety recommendations including Safety Recommendation 2011-053 recommending the amendment of CAP 437 to

encourage operators of vessels and offshore installations equipped with helidecks to adopt the new lighting standard presented as a final specification in Appendix C.

NOTE 2: The new lighting scheme has been developed to be compatible with helicopters having wheeled undercarriages, this being the prevailing configuration on the UKCS during the development of the specification and at the time of publication. Although the design specifications detailed in Appendix C will ensure the segments and subsections containing lighting elements are compliant with the ICAO maximum obstacle height of 25 mm and likely to be able to withstand the point loading presented by (typically) lighter skidded aircraft, compatibility should be considered before operating skidded helicopters to helidecks fitted with the new lighting. Due to the potential for raised fittings to induce dynamic rollover of helicopters equipped with skids, it is important that, where the new lighting scheme is installed on helidecks used by skid-fitted helicopters, the height of the system (including any mounting arrangements) should be kept as low as possible.

4.23 Although no longer recommended for the provision of primary visual cueing, the CAA has no objection to floodlighting systems conforming to the guidance contained in Appendix G being retained for the purpose of providing a source of illumination for on-deck operations such as refuelling and passenger handling and, where required, for lighting the installation name on the helideck surface or as a back-up to the new lighting (see Note 2 below). Unless otherwise instructed by the aircrew the floodlights should be switched off during the acquisition, approach to hover, landing and take-off phases. In addition, particular care should be taken to maintain correct alignment to ensure that floodlights do not cause dazzle or glare to pilots while either in-flight or landed on the helideck. All floodlights should be capable of being switched on and off at the pilot's request. The floodlighting controls should be accessible to, and controlled by, the HLO or Radio Operator.

4.24 For helidecks located on normally unattended installations (NUIs), it is essential to ensure that the main structure of the platform (or 'legs') are adequately illuminated to improve depth perception and to mitigate the

visual illusion that the landing area appears to be 'floating in space'. This is best achieved by providing, in consultation with the helicopter operator(s), floodlighting of the main structure beneath the helideck. Care should be taken to ensure that any potential source of glare from structure lighting is eliminated by directing it away from the approach path of the helicopter, and/or by providing louvres as appropriate.

NOTE: Prior to 1st April 2018 floodlighting may be retained as a temporary source of alternative helideck lighting, e.g. in the event of guano rendering the new circle-H lighting ineffective on some NUIs. It is the CAA's view that the guano problem should be addressed, but it may nevertheless be desirable to retain Appendix G compliant floodlighting as a temporary back-up on some installations.

Helideck status light system

4.25 A visual warning system should be installed if a condition can exist on an installation which may be hazardous for the helicopter or its occupants. The system (Status Lights) should be a flashing red light (or lights), visible to the pilot from any direction of approach and on any landing heading. The aeronautical meaning of a flashing red light is either “do not land, aerodrome not available for landing” or “move clear of landing area”. The system should be automatically initiated at the appropriate hazard level (e.g. gas release) as well as being capable of manual activation by the HLO. It should be visible at a range in excess of the distance at which the helicopter may be endangered or may be commencing a visual approach. CAA Paper 2008/01 provides a specification for a status light system which is summarised below:

- Where required, the helideck status signalling system should be installed either on or adjacent to the helideck. Additional lights may be installed in other locations on the platform where this is necessary to meet the requirement that the signal be visible from all approach directions, i.e. 360° in azimuth.

- The effective intensity should be a minimum of 700 cd between 2° and 10° above the horizontal and at least 176 cd at all other angles of elevation.
- The system should be provided with a facility to enable the output of the lights (if and when activated) to be dimmed to an intensity not exceeding 60 cd while the helicopter is landed on the helideck.
- The signal should be visible from all possible approach directions and while the helicopter is landed on the helideck, regardless of heading, with a vertical beam spread as shown in the second bullet point above.
- The colour of the status light(s) should be red, as defined in ICAO Annex 14 Volume 1 Appendix 1, Colours for aeronautical ground lights.
- The light system as seen by the pilot at any point during the approach should flash at a rate of 120 flashes per minute. Where two or more lights are needed to meet this requirement, they should be synchronised to ensure an equal time gap (to within 10%) between flashes. While landed on the helideck, a flash rate of 60 flashes per minute is acceptable. The maximum duty cycle should be no greater than 50%.
- The light system should be integrated with platform safety systems such that it is activated automatically in the event of a process upset.
- Facilities should be provided for the HLO to manually switch on the system and/or override automatic activation of the system.
- The light system should have a response time to the full intensity specified not exceeding three seconds at all times.
- Facilities should be provided for resetting the system which, in the case of NUIs, do not require a helicopter to land on the helideck.
- The system should be designed so that no single failure will prevent the system operating effectively. In the event that more than one light unit is used to meet the flash rate requirement, a reduced flash frequency of at least 60 flashes per minute is considered acceptable in the failed condition for a limited period.

- The system and its constituent components should comply with all regulations relevant to the installation.
- Where the system and its constituent components are mounted in the 210° OFS or in the first segment of the LOS, the height of the installed system should not exceed 25 cm above deck level (or exceed 5 cm for any helideck where the D-value is 16.00 m or less).
- Where supplementary 'repeater' lights are employed for the purposes of achieving the 'on deck' 360° coverage in azimuth, these should have a minimum intensity of 16 cd and a maximum intensity of 60 cd for all angles of azimuth and elevation

- 4.26 All components of the status light system should be tested by an independent test house to ensure verification with the specification in CAA Paper 2008/01. The photometrical and colour measurements performed in the optical department of the test house should be accredited according to the version of EN ISO/IEC 17025 current at the time of the testing.
- 4.27 Manufacturers are reminded that the minimum intensity specification stated above is considered acceptable to meet the **current** operational requirements, which specify a minimum meteorological visibility of 1400 m (0.75 NM). Development of offshore approach aids which permit lower minima (e.g. differential GPS) will require a higher intensity. Revised intensities are specified for the lowest anticipated meteorological visibility of 900 m (0.5 NM) in CAA Paper 2008/01, Appendix A.
- 4.28 Where helideck status light systems installed on normally unattended installations (NUIs) malfunction, whether the outcome is light(s) permanently flashing or disabled/depowered, in these cases, to allow them to be manually reset at the platform, a duty-holder may present a case-specific risk assessment to the helicopter operator, who if satisfied with the duty-holder's risk assessment, may raise a dispensation request to CAA Flight Operations (Helicopters) that, where accepted, would permit flights against operating status lights or black platforms to occur. A CAA

Protocol for operations against operating status lights or black decks is attached at Appendix I.

UPS requirement

- 4.29 Installation/vessel emergency power supply design should include the entire landing area lighting system (see Appendix C). Any failures or outages should be reported immediately to the helicopter operator. The lighting should be fed from an Uninterruptable Power Supply (UPS) system.

Obstacles – Marking and lighting

- 4.30 Fixed obstacles which present a hazard to helicopters should be readily visible from the air. If a paint scheme is necessary to enhance identification by day, alternate black and white, black and yellow, or red and white bands are recommended, not less than 0.5 metres nor more than six metres wide. The use of 'Day-Glo' orange may also be acceptable. The colour should be chosen to contrast with the background to the maximum extent. Paint colours should conform to the references at paragraph 4.18.
- 4.31 Obstacles to be marked in these contrasting colours include any lattice tower structures and crane booms, in addition to obstacles which are close to the helideck or the LOS boundary. Similarly, parts of the leg or legs of jack-up units adjacent to the landing area which extend, or can extend, above it should also be marked in the same manner. Lattice towers should be painted in their entirety.
- 4.32 Omnidirectional low intensity steady red obstruction lights conforming to the specifications for low intensity obstacle (Group A) lights described in [CAP 168 Licensing of Aerodromes](#), Chapter 4 and Table 6A.1, having a minimum intensity of 10 candelas for angles of elevation between 0 degrees and 30 degrees should be fitted at suitable locations to provide the helicopter pilot with visual information on the proximity and height of

objects which are higher than the landing area and which are close to it or to the LOS boundary. This should apply, in particular, to all crane booms on the installation or vessel. Objects which are more than 15 metres higher than the landing area should be fitted with intermediate low intensity steady red obstruction lights of the same intensity spaced at 10-metre intervals down to the level of the landing area (except where such lights would be obscured by other objects). It is often preferable for some structures such as flare booms and towers to be illuminated by floodlights as an alternative to fitting intermediate steady red lights, provided that the lights are arranged such that they will illuminate the whole of the structure and not dazzle the helicopter pilot. Such arrangements should be discussed with the helicopter operator. Offshore duty holders may, where appropriate, consider alternative equivalent technologies to highlight dominant obstacles in the vicinity of the helideck.

- 4.33 An omni-directional low intensity steady red obstruction light should be fitted to the highest point of the installation. The light should conform to the specifications for a low intensity obstacle (Group B) light described in [CAP 168 Licensing of Aerodromes](#), Chapter 4 and Table 6A.1, having a minimum intensity of 50 candelas for angles of elevation between 0 and 15 degrees, and a minimum intensity of 200 candelas between 5 and 8 degrees. Where it is not practicable to fit a light to the highest point of the installation (e.g. on top of flare towers) the light should be fitted as near to the extremity as possible.
- 4.34 In the particular case of jack-up units, it is recommended that when the tops of the legs are the highest points on the installation, they should be fitted with omni-directional low intensity steady red lights of the same intensity and characteristics as described in paragraph 4.33. In addition the leg or legs adjacent to the helideck should be fitted with intermediate low intensity steady red lights of the same intensity and characteristics as described in paragraph 4.32 at 10-metre intervals down to the level of the landing area. As an alternative the legs may be floodlit providing the helicopter pilot is not dazzled.

- 4.35 Any ancillary structure within one kilometre of the landing area, and which is 10m or more above helideck height, should be similarly fitted with red lights.
- 4.36 Red lights should be arranged so that the locations of the objects which they delineate are visible from all directions of approach above the landing area.
- 4.37 Installation/vessel emergency power supply design should include all forms of obstruction lighting. Any failures or outages should be reported immediately to the helicopter operator. The lighting should be fed from a UPS system.

Chapter 5

Helideck rescue and fire fighting facilities

Introduction

- 5.1 This Chapter sets out the requirements regarding provision of equipment, extinguishing media, personnel, training, and emergency procedures for offshore helidecks on installations and vessels.

Key design characteristics – Principal agent

- 5.2 A key aspect in the successful design for providing an efficient, integrated helideck rescue and fire fighting facility is a complete understanding of the circumstances in which it may be expected to operate. A helicopter accident, which results in a fuel spillage with wreckage and/or fire and smoke, has the capability to render some of the equipment inventory unusable or preclude the use of some passenger escape routes.
- 5.3 Delivery of fire fighting media to the landing area at the appropriate application rate should be achieved in the quickest possible time. The CAA strongly recommends that a delay of less than 15 seconds, measured from the time the system is activated to actual production at the required application rate, should be the objective. The operational objective should ensure that the system is able to bring under control a helideck fire associated with a crashed helicopter within 30 seconds measured from the time the system is producing foam at the required application rate for the range of weather conditions prevalent for the UKCS.
- NOTE:** A fire is deemed to be ‘under control’ at the point when it becomes possible for the occupants of the helicopter to be effectively rescued by trained fire-fighters.
- 5.4 Foam-making equipment should be of adequate performance and be suitably located to ensure an effective application of foam to any part of

the landing area irrespective of the wind strength/direction or accident location when all components of the system are operating in accordance with the manufacturer's technical specifications for the equipment. However, for a Fixed Monitor System (FMS), consideration should also be given to the loss of a downwind foam monitor either due to limiting weather conditions or a crash situation occurring. The design specification for an FMS should ensure remaining monitors are capable of delivering foam to the landing area at or above the minimum application rate. For areas of the helideck or its appendages which, for any reason, may be otherwise inaccessible to an FMS, it is necessary to provide additional hand-controlled foam branches as described in paragraph 5.12.

- 5.5 Consideration should be given to the effects of the weather on static equipment. All equipment forming part of the facility should be designed to withstand protracted exposure to the elements or be protected from them. Where protection is the chosen option, it should not prevent the equipment being brought into use quickly and effectively (see paragraph 5.3). The effects of condensation on stored equipment should be considered.
- 5.6 The minimum capacity of the foam production system will depend on the D-value of the helideck, the foam application rate, discharge rates of installed equipment and the expected duration of application. It is important to ensure that the capacity of the main helideck fire pump is sufficient to guarantee that finished foam can be applied at the appropriate induction ratio and application rate and for the minimum duration to the whole of the landing area when all helideck monitors are being discharged simultaneously.
- 5.7 The application rate is dependent on the types of foam concentrate in use and the types of foam application equipment selected. For fires involving aviation kerosene, ICAO has produced a performance test which assesses and categorises the foam concentrate. Most foam concentrate manufacturers will be able to advise on the performance of their

concentrate against this test. The CAA recommends that foam concentrates compatible with seawater and meeting at least performance level 'B' are used. Level B foams should be applied at a minimum application rate of 6.0 litres per square metre per minute.

5.8 **Calculation of Application Rate:** Example for a D-value 22.2 metre helideck (Level B foams) Application rate = $6.0 \times \pi \times r^2$ ($6.0 \times 3.142 \times 11.1 \times 11.1$) = 2322 litres per minute.

NOTE: ICAO Annex 14 Volume I and the Doc. 9137-AN/898 Airport Services Manual, Part 1 - Rescue and Fire-fighting Fourth Edition 2015 support the use of performance level C foams which are proven to be more efficient in their extinguishing ability than level B foams. It is established that the application rate for foam meeting performance level C may be reduced to 3.75 litres per square metre per minute and, where level C foams are selected for new systems, 3.75 may be used in the calculation in lieu of 6.0 litres.

Calculation of Application Rate: Example for a D-value 22.2 metre helideck (Level C foams) Application rate = $3.75 \times \pi \times r^2$ ($3.75 \times 3.142 \times 11.1 \times 11.1$) = 1452 litres per minute.

5.9 Given the remote location of helidecks the overall capacity of the foam system should exceed that necessary for initial extinction of any fire. Five minutes' discharge capability is generally considered by the CAA to be reasonable.

5.10 **Calculation of Minimum Operational Stocks:** Using the 22.2 metre example as shown in paragraph 5.8, a 1% foam solution discharged over five minutes at the minimum application rate will require $2322 \times 1\% \times 5 = 116$ litres of foam concentrate. A 3% foam solution discharged over five minutes at the minimum application rate will require $2322 \times 3\% \times 5 = 348$ litres of foam concentrate.

NOTE: Sufficient reserve foam stocks to allow for replenishment as a result of operation of the system during an incident, or following training or testing, will also need to be held.

- 5.11 Low expansion foam concentrates can generally be applied in either aspirated or unaspirated form. It should be recognised that whilst unaspirated foam may provide a quick knockdown of any fuel fire, aspiration, i.e. induction of air into the foam solution by monitor or by hand-controlled foam branch (see below), gives enhanced protection after extinguishment. Wherever non-aspirated foam equipment is selected during design, additional equipment capable of producing aspirated foam for post-fire security/control should be provided.
- 5.12 Not all fires are capable of being accessed by monitors and on some occasions the use of monitors may endanger passengers. Therefore, in addition to a fixed foam system monitor, there should be the ability to deploy at least two deliveries with hand-controlled foam branches for the application of aspirated foam at a minimum rate of 225 litres/min through each hose line. A single hose line, capable of delivering aspirated foam at a minimum application rate of 225 litres/min, may be acceptable where it is demonstrated that the hose line is of sufficient length, and the hydrant system of sufficient operating pressure, to ensure the effective application of foam to any part of the landing area irrespective of wind strength or direction. The hose line(s) provided should be capable of being fitted with a branch pipe capable of applying water in the form of a jet or spray pattern for cooling, or for specific fire fighting tactics. Where a Deck Integrated Fire Fighting System (DIFFFS) capable of delivering foam and/or seawater in a spray pattern to the whole of the landing area (see paragraphs 5.13 to 5.15 and Note below) is selected in lieu of an FMS, the provision of additional hand-controlled foam branches may not be necessary to address any residual fire situation. Instead any residual fire may be tackled with the use of hand-held extinguishers (see paragraph 4).
- 5.13 As an effective alternative to an FMS, offshore duty holders are strongly encouraged to consider the provision of DIFFFS. These systems typically consist of a series of 'pop-up' nozzles, with both a horizontal and vertical component, designed to provide an effective spray distribution of foam to the whole of the landing area and protection for the helicopter for the

range of weather conditions prevalent on the UKCS. A DIFFS should be capable of supplying performance level B or level C foam solution to bring under control a fire associated with a crashed helicopter within the time constraints stated in paragraph 5.3 achieving an average (theoretical) application rate over the entire landing area (based on the D-circle) of 6.0 litres per square metre per minute for level B foams or 3.75 litres per square metre per minute for level C foams, for a duration which at least meets the minimum requirements stated in paragraph 5.9.

- 5.14 The precise number and layout of pop-up nozzles will be dependent on the specific helideck design, particularly the dimensions of the critical area. However, nozzles should not be located adjacent to helideck egress points as this may hamper quick access to the helideck by trained rescue crews and/or impede occupants of the helicopter escaping to a safe place beyond the helideck. Notwithstanding this, the number and layout of nozzles should be sufficient to provide an effective spray distribution of foam over the entire landing area with a suitable overlap of the horizontal element of the spray pattern from each nozzle assuming calm wind conditions. It is recognised in meeting the objective for the average (theoretical) application rate specified in paragraph 2.10 for performance level B or C foams that there may be some areas of the helideck, particularly where the spray patterns of nozzles significantly overlap, where the average (theoretical) application rate is exceeded in practice. Conversely for other areas of the helideck the application rate in practice may fall below the average (theoretical) application rate specified in paragraph 5.13. This is acceptable provided that the actual application rate achieved for any portion of the landing area does not fall below two-thirds of the rates specified in paragraph 5.13 for the critical area calculation.

NOTE: Where a DIFFS is used in tandem with a passive fire-retarding system demonstrated to be capable of removing significant quantities of unburned fuel from the surface of the helideck in the event of a fuel spill from a ruptured aircraft tank, it is permitted to select a seawater-only DIFFS to deal with any residual fuel

burn. A seawater-only DIFFS should meet the same application rate and duration as specified for a performance level B foam DIFFS in paragraphs 5.13 and 5.14. (See also paragraph 5.29 for NUIs.)

- 5.15 In a similar way to where an FMS is provided (see paragraph 5.4), the performance specification for a DIFFS needs to consider the likelihood that one or more of the popup nozzles may be rendered ineffective by the impact of a helicopter on the helideck. Any local damage to the helideck, nozzles and distribution system caused by a helicopter crash should not unduly hinder the system's ability to deal effectively with a fire situation. To this end a DIFFS supplier should be able to verify that the system remains fit for purpose, in being able to bring a helideck fire associated with a crashed helicopter "under control" within 30 seconds measured from the time the system is producing foam at the required application rate for the range of weather conditions prevalent for the UKCS (see also paragraph 5.3).
- 5.16 If life saving opportunities are to be maximised it is essential that all equipment should be ready for immediate use on, or in the immediate vicinity of, the helideck whenever helicopter operations are being conducted. All equipment should be located at points having immediate access to the landing area. The location of the storage facilities should be clearly indicated.

Use and maintenance of foam equipment

- 5.17 Mixing of different concentrates in the same tank, i.e. different either in make or strength, is generally unacceptable. Many different strengths of concentrate are on the market. Any decision regarding selection should take account of the design characteristics of the foam system. It is important to ensure that foam containers and tanks are correctly labelled.
- 5.18 Induction equipment ensures that water and foam concentrate are mixed in the correct proportions. Settings of adjustable inductors, if installed, should correspond with strength of concentrate in use.

- 5.19 All parts of the foam production system, including the finished foam, should be tested by a competent person on commissioning and annually thereafter. The tests should assess the performance of the system against original design expectations while ensuring compliance with any relevant pollution regulations. Further information for testing of helideck foam production systems is stated in HSE OIS 6/2011, issued August 2011.

Complementary media

- 5.20 While foam is considered the principal medium for dealing with fires involving fuel spillages, the wide variety of fire incidents likely to be encountered during helicopter operations – e.g. engine, avionic bays, transmission areas, hydraulics – may require the provision of more than one type of complementary agent. Dry powder and gaseous agents are generally considered acceptable for this task. The complementary agents selected should comply with the appropriate specifications of the ISO. Systems should be capable of delivering the agents through equipment which will ensure effective application.

NOTE: Halon extinguishing agents are no longer specified for new installations. Gaseous agents, including CO₂, have replaced them. The effectiveness of CO₂ is accepted as being half that of halon.

- 5.21 The CAA recommends the use of dry powder as the primary complementary agent. The minimum total capacity should be 45 kg delivered from one or two extinguishers. The dry powder system should have the capacity to deliver the agent anywhere on the landing area and the discharge rate of the agent should be selected for optimum effectiveness of the agent. Containers of sufficient capacity to allow continuous and sufficient application of the agent should be provided.
- 5.22 The CAA recommends the use of a gaseous agent in addition to the use of dry powder as the primary complementary agent. Therefore, in addition to dry powder specified at paragraph 5.21, there should be a quantity of gaseous agent provided with a suitable applicator for use on engine fires. The appropriate minimum quantity delivered from one or two

extinguishers is 18 kg. The discharge rate of the agent should be selected for optimum effectiveness of the agent. Due regard should be paid to the requirement to deliver gaseous agents to the seat of the fire at the recommended discharge rate. Because of the weather conditions prevalent on the UKCS, all complementary agents could be adversely affected during application and training evolutions should take this into account.

- 5.23 All offshore helicopters have integral engine fire protection systems (predominantly halon) and it is therefore considered that provision of foam as the principal agent plus suitable water/foam branch lines plus sufficient levels of dry powder with a quantity of secondary gaseous agent will form the core of the fire extinguishing system. It should be borne in mind that none of the complementary agents listed will offer any post-fire security/control.
- 5.24 All applicators are to be fitted with a mechanism which allows them to be hand controlled.
- 5.25 Dry chemical powder should be of the 'foam compatible' type.
- 5.26 The complementary agents should be sited so that they are readily available at all times.
- 5.27 Reserve stocks of complementary media to allow for replenishment as a result of activation of the system during an incident, or following training or testing, should be held.
- 5.28 Complementary agents should be subject to annual visual inspection by a competent person and pressure testing in accordance with manufacturers' recommendations.

Normally unattended installations

NOTE: The criteria given in paragraphs 5.29 to 5.31 address current best practice criteria for new-build NUIs. For 117 existing NUI assets located on the UKCS a

number of alternative options were disseminated in the form of an industry letter dated 1 July 2011. This letter was reproduced in the seventh edition of CAP 437 in Appendix D - and is now retained in Appendix D2. However, on 1st July 2016 CAA agreed a new scheme with the industry aimed at addressing deficiencies in the fire fighting provisions at these 117 normally unattended installations (NUIs) operating on the UKCS. The scheme, detailed at Appendix D1, provides platform duty holders with a further degree of flexibility in meeting CAA's minimum requirements for effective fire fighting provisions, for both the cases when fire fighting equipment is attended and when it is unattended, in order to adequately mitigate the reasonably foreseeable event of a post crash fire on an NUI. The scheme is summarised in a table in Appendix D1 and is based on an agreed start date of 1st January 2017. The Scheme is underpinned by a CAA Safety Directive addressing offshore Helicopter Helideck Operations.

- 5.29 In the case of new-build NUIs, the selection and provision of foam should be assumed as the principal agent. For an NUI, where helideck Rescue and Fire Fighting (RFF) equipment will be unattended during certain helicopter movements, the pressurised discharge of foam through a manually operated fixed monitor system is not recommended. For installations which are at times unattended the effective delivery of foam to the whole of the landing area is best achieved by means of a DIFFS. See paragraphs 5.13 to 5.15.
- 5.30 For NUIs the CAA may also consider other 'combination solutions' where these can be demonstrated to be effective in dealing with a running fuel fire. This may permit, for example, the selection of a seawater-only DIFFS used in tandem with a passive fire-retarding system demonstrated to be capable of removing significant quantities of unburned fuel from the surface of the helideck in the event of a fuel spill from a ruptured aircraft tank.
- 5.31 DIFFS on NUIs should be integrated with platform safety systems such that pop-up nozzles are activated automatically in the event of an impact of a helicopter on the helideck where a Post-Crash Fire (PCF) is the outcome. The overall design of a DIFFS should incorporate a method of fire detection and be configured to avoid spurious activation. It should be

capable of manual over-ride by the HLO and from the mother installation or from an onshore control room. Similar to a DIFFS provided for a Permanently Attended Installation (PAI) or vessel, a DIFFS provided on an NUI needs to consider the eventuality that one or more nozzles may be rendered ineffective by, for example, a crash. The basic performance assumptions stated in paragraphs 5.13 to 5.15 should also apply for a DIFFS located on an NUI.

The management of extinguishing media stocks

- 5.32 Consignments of extinguishing media should be used in delivery order to prevent deterioration in quality by prolonged storage.
- 5.33 The mixing of different types of foam concentrate may cause serious sludging and possible malfunctioning of foam production systems. Unless evidence to the contrary is available it should be assumed that different types are incompatible. In these circumstances it is essential that the tank(s), pipework and pump (if fitted) are thoroughly cleaned and flushed using fresh water prior to the new concentrate being introduced.
- 5.34 Consideration should be given to the provision of reserve stocks for use in training, testing and recovery from emergency use.

Rescue equipment

- 5.35 In some circumstances, lives may be lost if simple ancillary rescue equipment is not readily available.
- 5.36 The CAA strongly recommends the provision of at least the following equipment. Sizes of equipment are not detailed but should be appropriate for the types of helicopter expected to use the facility.

Helicopter RFF category		
	H1 / H2	H3
Adjustable wrench	1	1
Rescue axe, large (non wedge or aircraft type)	1	1
Cutters, bolt	1	1
Crowbar, large	1	1
Hook, grab or salving	1	1
Hacksaw (heavy duty) and six spare blades	1	1
Blanket, fire resistant	1	1
Ladder (two-piece)*	1	1
Life line (5 mm circumference x 15 m in length) plus rescue harness	1	1
Pliers, side cutting (tin snips)	1	1
Set of assorted screwdrivers	1	1
Harness knife and sheath or harness cutters**	**	**
Man-Made Mineral Fibre (MMMMF) Filter masks**	**	**
Gloves, fire resistant**	**	**
Power cutting tool***	-	1

* For access to casualties in an aircraft on its side.

** This equipment is required for each helideck crew member.

*** Requires additional approved training by competent personnel.

5.37 A responsible person should be appointed to ensure that the rescue equipment is checked and maintained regularly. Rescue equipment should be stored in clearly marked and secure watertight cabinets or chests. An inventory checklist of equipment should be held inside each equipment cabinet/chest.

Personnel levels

- 5.38 The facility should have sufficient trained fire fighting personnel immediately available whenever aircraft movements are taking place. They should be deployed in such a way as to allow the appropriate fire fighting and rescue systems to be operated efficiently and to maximum advantage so that any helideck incident can be managed effectively. The HLO should be readily identifiable to the helicopter crew as the person in charge of helideck operations. The preferred method of identification is a brightly coloured 'HLO' tabard. For guidance on helideck crew composition refer to the OGUK Guidelines for the Management of Aviation Operations.

Personal Protective Equipment (PPE)

- 5.39 All responding rescue and fire fighting personnel should be provided with appropriate PPE to allow them to carry out their duties in an effective manner.
- 5.40 Sufficient Helideck Emergency Response Trained personnel to operate the RFF equipment effectively should be dressed in protective clothing prior to helicopter movements taking place.
- 5.41 For the selection of appropriate PPE account should be taken of the Provision and Use of Work Equipment Regulations (PUWER) and the Personal Protective Equipment at Work Regulations (PPEWR), which require equipment to be suitable and safe for intended use, maintained in a safe condition and (where appropriate) inspected to ensure it remains fit for purpose. In addition, equipment should only be used by personnel who have received adequate information, instruction and training. PPE should be accompanied by suitable safety measures (e.g. protective devices, markings and warnings). Appropriate PPE should be determined through a process of risk assessment.

- 5.42 A responsible person(s) should be appointed to ensure that all PPE is installed, stored in sufficiently sized storage with drying facilities, used, checked and maintained in accordance with the manufacturer's instructions.

Training

- 5.43 If they are to effectively utilise the equipment provided, all personnel assigned to RFF duties on the helideck should be fully trained to carry out their duties to ensure competence in role and task. The CAA recommends that personnel attend an established helicopter fire fighting course.
- 5.44 In addition, regular training in the use of all RFF equipment, helicopter familiarisation and rescue tactics and techniques should be carried out. Correct selection and use of principal and complementary media for specific types of incident should form an integral part of personnel training.

Emergency procedures

- 5.45 The installation or vessel emergency procedures manual should specify the actions to be taken in the event of an emergency involving a helicopter on or near the installation or vessel. Exercises designed specifically to test these procedures and the effectiveness of the fire fighting teams should take place at regular intervals.

Further advice

- 5.46 Advice is available from the CAA's Aerodrome Standards Department regarding the choice and specification of fire extinguishing agents.

Chapter 6

Miscellaneous operational standards

Landing area height above water level

- 6.1 In consideration of the effects upon aircraft performance in the event of an engine failure (see Chapter 2) the height of the landing area above water level will be taken into account when deciding on any operational limitations to be applied to specific helidecks. Landing area height above water level is to be included in the information supplied on the helideck template for the purpose of authorising the use of the helideck (see Appendix A).

Wind direction (vessels)

- 6.2 The ability of a vessel to manoeuvre may be helpful in providing an acceptable wind direction in relation to the helideck location and information provided should include whether the installation or vessel is normally fixed at anchor, single point moored, or semi- or fully manoeuvrable.

Helideck movement

- 6.3 Floating installations and vessels experience dynamic motions due to wave action which represent a potential hazard to helicopter operations. Operational limitations are therefore set by the helicopter operators which are promulgated in the HLL and incorporated in their Operations Manuals. Helideck downtime due to excessive deck motion can be minimised by careful consideration of the location of the helideck on the installation or vessel at the design stage. Guidance on helideck location and how to assess the impact of the resulting helideck motion on operability is presented in CAA Paper 2008/03 'Helideck Design Considerations –

Environmental Effects' which is available on the Publications section of the CAA website at www.caa.co.uk. It is strongly recommended that mobile installation and vessel designers consult CAA Paper 2008/03 at the earliest possible stage of the design process.

- 6.4 In the interests of safety, the helicopter pilots need to know the magnitude and rate of movement of the helideck surface. The helicopter operator's Operations Manual limitations specify the movement of the helideck in terms of pitch, roll, inclination, and Significant Heave Rate (SHR). It is necessary for details of these motions to be recorded by the vessel's Helideck Monitoring System (HMS) and reported as part of the overall Offshore Weather Report (see Appendix E) prior to, and during, all helicopter movements. A helideck motion status 'traffic light' indication should be displayed on the HMS to indicate whether the deck is 'in limits' for approach to land (BLUE (or GREEN) = deck safe for landing) or whether 'out of limits' for approach to land (RED = nil landing).

NOTE: Vessel heading is also important on some types of vessel as this can affect the visual cues that will be available to the pilot on landing.

- 6.5 Pitch and roll reports to helicopters should include values, in degrees, about both axes of the true vertical datum (i.e. relative to the true horizon). It is important that reported values are only related to the true vertical and do not relate to any 'false' datum (i.e. a 'list') created, for example, by anchor patterns or displacement. Pitch should be expressed in terms of 'up' and 'down'; roll should be expressed in terms of 'left' and 'right'; helideck inclination is the angle measured in degrees between the absolute horizon and the plane of the helideck. The pitch, roll and inclination values reported to the helicopter should be the maximum values measured during the previous 20 minutes and should be reported to one decimal place.
- 6.6 The SHR value, being twice the Root Mean Square (RMS) heave rate measured over the previous 20-minute period, should be reported in metres per second to one decimal place. Due to the nature of the SHR

signal, the following trigger logic should be applied to the SHR input to the helideck motion status:

- The helideck motion status becomes RED if:
 - the HR limit is exceeded; **and**
 - all of the records in the previous 2 minutes have also exceeded the HR limit (or equivalently, the minimum SHR in the previous 2 minutes exceeds the HR limit).
- Once the deck motion status is RED, it becomes GREEN again only if:
 - the SHR falls below 95% of the HR limit, **and**
 - the mean of the records in the previous 10 minutes is below the HR limit.

NOTE: For helicopter operations on the UKCS, the long-standing helideck heave limitation was replaced by heave rate in November 2010. Heave rate is considered to be a more appropriate parameter and has been used in the Norwegian sector for many years. The measure of heave rate recommended (SHR) is different to that previously used in the Norwegian sector (Maximum Average Heave Rate (MAHR)), and has been adopted because it provides a simpler, less ambiguous and more representative measure of heave rate than MAHR.

6.7 It is strongly recommended that all moving helidecks are equipped with electronic motion-sensing systems (i.e. HMS) which are necessary to calculate SHR, and also provide an appropriate level of accuracy and integrity for all safety critical helideck motion information. A suitable HMS standard is published by the Helideck Certification Agency (Standard Helideck Monitoring Systems Rev 8c 2012 07 23 – see www.helidecks.org).

6.8 A new specification is presently being produced and validated through in-service trials which will add the following functions to the HMS:

- Improved, 'standardised' system displays to reduce the incidence of helideck motion reporting errors.

- Deck-mounted helideck motion status repeater lights to provide helicopter pilots with a direct means of establishing the motion status of the helideck, which are necessary to support the relative wind monitoring function.
- Relative wind monitoring function to detect unsafe wind conditions after landing due, for example, to the passage of 'line squalls' or loss of vessel heading control.
- Advisory only Motion Severity Index (MSI)/Wind Severity Index (WSI) scheme. Research has indicated that the likelihood of a helicopter tipping or sliding on a moving helideck is directly related to helideck accelerations and to the prevailing wind conditions. The MSI and WSI parameters relate directly to these phenomena. The scheme is to initially be introduced with a conservative, generic limit covering all helicopter types. It is expected that validated helicopter type-specific limits will be introduced as and when produced by helicopter manufacturers.

Helideck motion reporting

6.9 Information on helideck movement should be passed to the helicopter in an unambiguous format using a standard radio message. This will, in most cases, be sufficient to enable the helicopter flight crew to make safety decisions. Should the helicopter flight crew require other motion information or amplification of the standard message, the crew will request it (for example, yaw and heading information). For further guidance refer to [CAP 413 Radiotelephony Manual](#).

6.10 The following provides a representative example of the correct message format:

- **Situation:** The maximum vessel movement (over the preceding 20-minute period) about the pitch axis is 2.1° up and 2.3° down. The maximum vessel movement (over the preceding 20-minute period) about the roll axis is 1.6° to port and 3.6° to starboard (i.e. this vessel may have a permanent list of 1° to starboard and is rolling a

further 2.6° either side of this 'false' datum). The SHR recorded over the preceding 20-minute period is 1.1 metres per second. The maximum helideck inclination is 2.8°.

- **Report:** "Pitch 2.1° up and 2.3° down; roll 1.6° left and 3.6° right; Significant Heave Rate 1.1 metres per second; maximum helideck inclination 2.8°".

Meteorological information

(Relevant references are listed in Appendix B.)

(Additional guidance is listed in Appendix E.)

6.11 Accurate, timely and complete meteorological observations are necessary to support safe and efficient helicopter operations.

Meteorological observations

6.12 In addition to the data covered by paragraph 6.3, it is strongly recommended that installations are provided with an automated means of ascertaining the following meteorological information at all times:

- wind speed and direction (including variations in direction);
- air temperature and dew point temperature;
- QNH and, where applicable, QFE;
- cloud amount and height of base (Above Mean Sea Level (AMSL));
- visibility; and
- present weather.

NOTE 1: Where an installation is within 10nm of another installation that is equipped with an automated means of ascertaining the cloud amount and height of base, visibility and present weather, and which also makes this information routinely available to other installations, the output from the sensors may be used by the other installation's Met Observer as the basis for a report providing that the information has been manually checked and qualified before it is issued.

NOTE 2: Appropriate consideration and provision for service continuity of automated observing equipment should be made, including any necessary support facilities, such as back-up equipment and power.

NOTE 3: Contingency meteorological observing equipment providing manual measurements of air and dew point temperatures, wind speed and direction and pressure is recommended to be provided in case of the failure or unavailability of the automated sensors.

Assessment of wind speed and direction

6.13 For recording purposes an anemometer positioned in an unrestricted air flow is required. A second anemometer, located at a suitable height and position, can give useful information on wind velocity at hover height over the helideck in the event of turbulent or disturbed air flows over the deck. An indication of wind speed and direction should also be provided visually to the pilot by the provision of a wind sock coloured so as to give maximum contrast with the background (see also Chapter 4, paragraph 4.5).

Reporting of meteorological information

6.14 Up-to-date, accurate meteorological information is used by helicopter operators for flight planning purposes and by crews to facilitate the safe operation of helicopters in the take-off and landing phases of flight. Reports should be provided by the Met Observer at the platform concerned and not by Met Observers located on neighbouring platforms or from safety boats in the vicinity.

Pre-flight weather reports

6.15 The latest weather report from each installation should be made available to the helicopter operator one hour before take-off. These reports should contain:

- the name and location of the installation;
- the date and time the observation was made;
- wind speed and direction;

- visibility;
- present weather (including presence of lightning);
- cloud amount and height of base;
- temperature and dew point;
- QNH and QFE;
- SHR;
- pitch and roll;
- helideck inclination; and
- details of unserviceable Met sensors (including the original date that the sensor became unserviceable).

Where measured, the following information should also be included in the weather report:

- significant wave height.

NOTE: Additional non-meteorological information may be required to be provided, e.g. fuelling installation, radio frequencies or passenger numbers.

Radio messages

6.16 A standard radio message should be passed to the helicopter operator which contains information on the helideck weather in a clear and unambiguous format. When passing weather information to flight crews it is recommended that the information be consistently sent in a standard order as detailed in [CAP 413 'Radiotelephony Manual'](#) and in the [OGUK 'Guidelines for the Management of Aviation Operations'](#). This message will usually be sufficient to enable the helicopter crew to make informed safety decisions. Should the helicopter crew require other weather information or amplification of the standard message they will request it.

Collection and retention of meteorological information

6.17 Records of all meteorological reports that are issued are required to be retained for a period of at least 30 days.

Real-time web-based systems

- 6.18 North Sea offshore installations should supply meteorological information to the UK oil and gas industry's web-based system (Helimet). Helimet provides an efficient and consistent method of submitting weather reports and information from automated sensors to the helicopter operators. This enables a greater sharing of weather information so that helicopter operators, installation duty holders and others can access the latest information in one place and in real time, thereby enhancing users' situational awareness of weather conditions across the North Sea. Helimet also performs some verification of information submitted via the system which reduces the risk of data entry errors. Where appropriate, AUTO METARS may be generated from these reports which, provided all the required parameters are being generated, may be made available on the Aeronautical Fixed Service (AFS) channels, including the Aeronautical Fixed Telecommunications Network (AFTN).

Meteorological observer training

- 6.19 Personnel who carry out meteorological observations on offshore installations should undergo formal meteorological observer training and be certificated by a CAA approved training organisation for this role. Observers should complete refresher training provided by a CAA approved training organisation every two years to ensure they remain familiar with any changes to meteorological observing practices and procedures.
- 6.20 Training on the use of contingency meteorological equipment and procedures should be provided to enable a suitable level of accuracy and regularity of observations to be maintained in case of the failure or unavailability of automated sensors.

Calibration of meteorological equipment sensors

- 6.21 Calibration of primary and back-up meteorological equipment sensors used to provide the data listed in paragraph 6.12 should be periodically

carried out in accordance with the manufacturers' recommendations in order to demonstrate continuing adequacy for purpose.

Location in respect to other landing areas in the vicinity

- 6.22 Mobile installations and support vessels with helidecks may be positioned adjacent to other installations so that mutual interference/overlap of obstacle protected surfaces occur. Also on some installations there may be more than one helideck which may result in a confliction of obstacle protected surfaces.
- 6.23 Where there is confliction as mentioned above, within the OFS and/or falling gradient out to a distance that will allow for both an unobstructed departure path and safe clearance for obstacles below the helideck in the event of an engine failure for the type of helicopter the helideck is intended to serve (see also Glossary of Terms. Note: for helicopters operated in Performance Class 1 or 2 the horizontal extent of this distance from the helideck will be based upon the one-engine inoperative capability of the helicopter type to be used), simultaneous operation of two helicopter landing areas is not to take place without prior consultation with the helicopter operator. It is possible, depending upon the distance between landing areas and the operational conditions which may pertain, that simultaneous operations can be permitted but suitable arrangements for notification of helicopter crews and other safety precautions will need to be established. In this context, 'flotels' will be regarded in the same way as any other mobile installation which may cause mutual interference with the parent installation approach and take-off sector. For a detailed treatment of this subject readers are recommended to refer to the OGUK 'Guidelines for the Management of Aviation Operations'. See also Chapter 3 which addresses issues from the perspective of the impact of environmental effects on helideck operations.

Control of crane movement in the vicinity of landing areas

- 6.24 Cranes can adversely distract pilots' attention during helicopter approach and take-off from the helideck as well as infringe fixed obstacle protected surfaces. Therefore it is essential that when helicopter movements take place (± 10 minutes) crane work ceases and jibs, 'A' frames, etc. are positioned clear of the obstacle protected surfaces and flight paths.
- 6.25 The HLO should be responsible for the control of cranes in preparation for and during helicopter operations.

General precautions

- 6.26 Whenever a helicopter is stationary on board an offshore installation with its rotors turning, except in case of emergency, no person should enter upon or move about the helicopter landing area otherwise than within view of a helicopter flight crew member or the HLO and at a safe distance from its engine exhausts and tail rotor. It may also be dangerous to pass under the main rotor disc in front of helicopters which have a low main rotor profile.
- 6.27 The practical implementation of paragraph 6.26 is best served through consultation with the helicopter operator for a clear understanding of the approach paths approved for personnel and danger areas associated with a rotors-running helicopter. These areas are type-specific but, in general, the approved routes to and from the helicopter are at the 2–4 o'clock and 8–10 o'clock positions. Avoidance of the 12 o'clock (low rotor profile helicopters) and 6 o'clock (tail rotor danger areas) positions should be maintained.
- 6.28 Personnel should not approach the helicopter while the helicopter anti-collision (rotating/flashing) beacons are operating. In the offshore environment, the helideck should be kept clear of all personnel while anti-collision lights are on.

Installation/Vessel helideck operations manual and general requirements

- 6.29 The maximum helicopter mass and D-value for which the deck has been designed and the maximum size and weight of helicopter for which the installation is certified should be included in the Operations Manual. The extent of the obstacle-free area should also be stated and reference made to any helideck operating limitation imposed by helicopter operators as a result of any non-compliance. Non-compliances should also be listed.

Helicopter operations support equipment

- 6.30 Provision should be made for equipment needed for use in connection with helicopter operations including:
- chocks and tie-down strops/ropes (strops are preferable);
 - heavy-duty, calibrated, accurate scales for passenger baggage and freight weighing;
 - a suitable power source for starting helicopters if helicopter shut-down is seen as an operational requirement; and
 - equipment for clearing the helicopter landing area of snow and ice and other contaminants.
- 6.31 Chocks should be compatible with helicopter undercarriage/wheel configurations. Helicopter operating experience offshore has shown that the most effective chock for use on helidecks is the 'NATO sandbag' type. Alternatively, 'rubber triangular' or 'single piece fore and aft' type chocks may be used as long as they are suited to all helicopters likely to operate to the helideck. The 'rubber triangular' chock is generally only effective on decks without nets.
- 6.32 For securing helicopters to the helideck it is recommended that adjustable tie-down strops are used in preference to ropes. Specifications for tie-downs should be agreed with the helicopter operators.

- 6.33 Detailed guidance on the provision and operation of aeronautical communications and navigation facilities associated with offshore helicopter landing areas is given in the UKOOA publications 'Guidelines for the Management of Aviation Operations' and 'Guidelines for Safety Related Telecommunications Systems On Fixed Offshore Installations'.
- 6.34 Offshore Radio Operators, HLOs, Helideck Assistants and other persons who operate VHF aeronautical radio equipment are required to hold a UK CAA Offshore Aeronautical Radio Station Operator's Certificate of Competence. Further information can be found in CAP 452 'Aeronautical Radio Station Operator's Guide' and CAP 413 'Radiotelephony Manual' which can be found on the CAA website at www.caa.co.uk/cap452 and www.caa.co.uk/cap413.
- 6.35 Offshore fixed installations, mobile installations and vessels which have aeronautical radio equipment and/or aeronautical Non-Directional Radio Beacons (NDBs) installed on them and are operating in UK Internal Waters, UK Territorial Waters or within the limits of the UKCS are required to hold a valid Wireless Telegraphy (WT) Act licence and Air Navigation Order (ANO) approval. It should be noted, however, that the provision of an NDB on fixed installations, mobile installations and vessels is not mandatory and use should be discussed with the provider of helicopter services to ascertain their needs. The UK CAA Form SRG 1417 'Application to Establish or Change an Aeronautical Ground Radio Station' may be to apply for both the WT Act licence and ANO approval and can be found on the CAA website at www.caa.co.uk/srg1417.
- 6.36 The UK Office of Communications (Ofcom) has an agreement with the UK CAA, Directorate of Airspace Policy (DAP), Surveillance and Spectrum Management (S&SM) to administer WT Act licences for aircraft, aeronautical (ground) radio stations and navigation aids on their behalf. Further information can be found on the CAA website at www.caa.co.uk/radiolicensing.

Chapter 7

Helicopter fuelling facilities – Systems design and construction

General

- 7.1 The contents of this chapter are intended to give general advice/best practice for the design and construction requirements for helicopter fuelling systems intended for use on fixed offshore installations, Mobile Offshore Units and vessels. The information has been compiled by Oil & Gas UK in consultation with the UK offshore oil and gas industry and specialist fuelling companies. Additionally, as a reference document for best practice, the information provided herein should act as guidance for the continued improvement of existing offshore helicopter fuelling systems. As refuelling equipment technology and design improves, when the risks associated with offshore helicopter fuelling can be further reduced by implementing improvements and / or alternate technical solutions, this should be carried out whenever practicable. Works undertaken on existing refuelling systems that are subject to repair and / or refurbishment should, where practicable and economically viable, comply with these standards and guidelines.
- 7.2 This chapter has been prepared with the relevant content of [CAP 748 'Aircraft Fuelling and Fuel Installation Management'](#) in mind. However, additional detailed technical information and codes of practice can be obtained from the EI/JIG (Energy Institute and Joint Inspection Group) Standard 1530, EI Aviation Fuel Handling Standards and JIG Standards 1 to 4. Where the reader is referred to other standards or alternative guidance, the reference documents used should always be checked by the reader to ensure they are up-to-date and reflect current best practice.
- 7.3 Jet A-1 refuelling systems designed and manufactured by an OEM for installation on Mobile Offshore Units and vessels by the owner /

purchaser, should also comply with classification society rules (e.g. ABS, Bureau Veritas, DNV-GL, and Lloyds Register) to meet the end requirements for gaining a Certificate of Compliance.

Product identification

7.4 It is essential to ensure at all times that aviation fuel delivered to helicopters from offshore installations and vessels is of the highest quality. A major contributor toward ensuring that fuel quality is maintained and contamination is prevented is to provide clear and unambiguous product identification on all system components and pipelines denoting the fuel type (e.g. Jet A-1) following the standard aviation convention for markings and colour code. Details can be found in EI Standard 1542 'Identification markings for dedicated aviation fuel manufacturing and distribution facilities, airport storage and mobile fuelling equipment'. The correct identification markings should initially be applied during system manufacture and routinely checked for clarity during subsequent maintenance inspections.

Fuelling system description

7.5 It should be noted that an offshore fuelling system may vary according to the particular application for which it was designed. Nevertheless the elements of all offshore fuelling systems are basically the same and refuelling systems will generally fall into one of two categories:

'Transportable Tank System' consisting of:

- transit tanks,
- a fuel delivery pumping system, and
- a dispensing system.

'Static Storage Tank System' consisting of:

- static storage facilities and, if installed, a sample reclaim tank (see note),

- fuel delivery and fuel transfer pumping systems or a combined delivery and transfer pumping system,
- a dispensing system, and
- transit tanks.

NOTE: On existing (legacy) Transportable Tank Systems where built-in static storage tanks are not provided, delivery of fuel is direct to the aircraft from transit tanks. In this case, sample reclaim tanks should not be used in order to prevent un-quantified mixing of fuel batches within transit tanks; where fuel relative density requires to be tightly controlled.

Design considerations

- 7.6 When preparing a layout design for aviation fuelling systems on offshore installations and vessels it is important to make provisions for suitable segregation and bunding of the areas set aside for the tankage, pumping and dispensing systems. Facilities for containing possible fuel leakage until waste fuel can be properly disposed of should be given full and proper consideration.
- 7.7 Although Jet A-1 is a flammable hydrocarbon, it is a relatively safe fuel in comparison to other shorter-chain hydrocarbons, having a flash point of 38°C, and is designed to ignite in an atomised form as it is injected into an aircraft engine. It is not designed to burn in liquid form at temperatures below its flashpoint. System design should therefore take into consideration engineering controls to prevent fuel from being exposed to conditions similar to ideal ignition conditions as the presence of Jet A-1 in an offshore environment constitutes a major safety hazard.
- Proximity to heat sources may necessitate consideration of heat shielding.
 - Earth bonding is a requirement throughout the system, from tank earthing leads and clamps, through system pipework and equipment bonding to nozzle ground wires and the main aircraft earth bonding

lead as the movement of fuel and system components will generate electrostatic charge.

- Protection of system components from over-pressurisation due to thermal expansion should be considered, especially in sections of the system where components can be isolated from the mandatory filter water separator thermal expansion relief valve by closure of isolation valves.
- Provision of fire control should be given full and proper consideration.
- Adequate protection should be provided from potential dropped objects (e.g. due to crane operations) which could cause uncontrolled release of fuel under pressure if damage were to occur, or the potential effects should be mitigated.
- Any tank top openings that are easily opened should have the capability of being locked or having a frangible seal installed to verify contents have not been tampered with.

Static storage tanks

- 7.8 All New Build Offshore Static Storage Tank Fuelling Systems should provide static storage tanks constructed to suitable standards. Acceptable standards include ASME VIII, PED 97/23/EC and EN13445. The tank should be cylindrical and mounted with an obstacle free centre line slope (e.g. no baffles fitted) to a small sump or low point. This slope should be at least 1 in 30, although 1 in 25 is preferred.
- 7.9 Tanks may be constructed from stainless steel or mild steel. If mild steel is used, then the tanks should be lined internally with a suitable white coloured, fuel-resistant epoxy lining. External surfaces should be lined with a suitable paint system to resist the marine operating environment and fuel spillage.
- 7.10 Tanks should be clearly and permanently marked on the identification plate with the tank capacity and tank serial number.
- 7.11 Static tanks should be equipped with the following:

Manhole

1. A 450 mm (18”) or greater diameter manhole which should normally be hinged to assist easy opening.

Inspection hatch

2. A 150 mm (6”) sample hatch to allow for a visual inspection of the low end of the tank or for taking mid level and high level samples (e.g. using a sample flask) in order to investigate fuel contamination issues.

Contents measuring device

3. A suitable dipstick or dip-tape should be provided, with a means of access to the tank interior. A sight glass or contents gauge may also be provided to determine the tank contents. Additionally, tanks may be fitted with low and high level transmitters interfaced with the control system to safeguard against pump cavitation and to prevent overfilling.

NOTE: A dipstick is required to accurately determine the tank contents and the amount of usable fuel remaining in the tank. This will not be achieved using a level gauge and thus, it will increase the risk of entrained air being delivered into the aircraft fuel tanks.

Vent

4. A free vent or an emergency pressure/vacuum relief valve should be fitted. Type and pressure settings should be in accordance with the manufacturer’s recommendations.

Outlet and fill connections.

5. Separate outlet and fill connections with the fill point arranged so that there is no free-fall of product at any stage of the tank filling. The draw-off point for the tank should be designed such that there is at least 150 mm (6”) of ‘dead-stock’ fuel when the tank breaks suction. This can be achieved by either positioning the draw-off point higher than the lowest point of the tank or preferably by use of a floating suction arm.

Sample connection

6. A stainless steel sample point should be fitted to the sump at the lowest point of the tank. The sample line should be double valved with the downstream valve being a full bore ball valve to prevent trapping of sediment and to allow samples to be taken under full flow conditions in a controlled manner. Where practicable, the downstream valve should have spring return operation as a safety feature. Sample lines should be a minimum of 19 mm ($\frac{3}{4}$ ") nominal bore but preferably 25 mm (1") nominal bore. It should terminate with a captive dust cap at a location conducive to sampling operations and positioned such as to allow sufficient access, space and height to accommodate at least a standard 3 litre sample jar, but preferably able to accommodate a 12 litre stainless steel sampling bucket.

Floating suction.

7. When floating suction is embodied then a bonded floating suction check wire pull assembly should be fitted directly to the top of the tank. Floating suction offers some advantages over other outlet types, including shorter fuel settling times after replenishment, and is therefore strongly recommended. However, the size and shape of the tank should also be considered to determine suitability for incorporating into a fixed or mobile installation design along with the capacity required to service the intended offshore helicopter operations.

Remotely operated closure valves

8. Remotely operated quick closure valves for fill and discharge points should be fitted. These may be integral to the tank, such as an actuated foot valve arrangement, or may be mounted to the tank nozzles. These valves should be capable of operation from both the helideck and from another point which is at a safe distance from the tank.

Tank shell outer surface finish.

9. The static storage tank shell should be suitably primed and then finished in safety yellow (BS 4800, Type 08.E.51). Where the tank shell is fabricated from stainless steel it may remain unpainted. Safety yellow is not mandatory but has been generally accepted for helifuel tanks. All component parts should be properly bonded for earth continuity before being painted. Whether the tank barrel is painted yellow or otherwise, Jet A-1 static storage tanks should be correctly identified by placing clear product identification markings on all sides, particularly above the tank outlet and fill connections.

Tank shell inner surface finish.

10. The internal finish should be sufficiently smooth to ensure that liquid run-off is clean and allow the tank to be wiped down during internal inspections without dragging threads or lint from the cleaning cloth. Weld roots should be laid or ground flush with the bottom centre-line of the tank to prevent water or contaminant traps.

Sample reclaim tank

- 7.12 If the fuelling system includes a static storage tank, water-free and sediment-free fuel samples can be disposed of into a dedicated reclaim tank (if installed). The sample reclaim tank should be equipped with a removable 100 mesh strainer at the fill point, a lockable sealing lid, a conical or dished base (slope of 1 in 20 is recommended) with a sample point at the sump and a return line (fitted with a check valve) to re-introduce reclaimed fuel to the storage tank via an EI 1581 approved filter water separator or an approved EI 1583 filter monitor. In addition, sample reclaim tanks should include the following:

- Means for access and visual inspection.
- Means to prevent spillage / overflow.
- Means for venting.
- Suitable secondary containment as applicable.

- Suitable identification to denote its use (e.g. "Jet A-1 Recovery Tank Intended for Aviation Use").
- Tank should have sloped bottom to a positive sump with a drain for sampling contents prior to decant.
- Pump pick-up should be designed such that a quantity of dead-stock remains in the sample reclaim tank upon breaking suction during sample reclamation which should then be removed through the drain point and disposed of. Quantity of dead-stock may vary dependent on tank design, but should not be less than 10 litres.
- All tank appurtenances, access entrances, vents, inspection ports, etc. should be accessible, and designed to prevent the ingress of contaminants.

7.13 Where the system does not include a functioning static storage tank and fuelling is direct from transit tanks, if a sample reclaim tank has been installed fuel samples may be drained to it. However, the reclaim tank contents should only be decanted directly from the sample point into drums or other suitable receptacles and then properly disposed of.

Delivery system

7.14 The delivery system to pump fuel from static storage tanks or transit tanks to the aircraft should include the following components:

Suction hose and hose unit.

1. In order to connect transit tanks to the pumping system pipework, a flexible suction hose with 2½" self-sealing hose unit requires to be fitted. In order to reduce yellow metal contact with fuel, stainless steel hose units should ideally be used, however, aluminium is currently acceptable. The hose unit should be fitted with a captive dust plug. The suction hose should be an approved, smooth bore, semi-conducting type to EN ISO 1825:2011 Type C, Grade 2, and should be as a minimum, 50 mm (2") nominal bore fitted with reusable safety clamp adaptors. Dependent on pump suction characteristics, it may be necessary to use one of the hose variants with an integral reinforcing galvanised wire or non-metallic helix.

Suitable types include the Elaflex TW 50 or TW-E 50 range. Historically, single or double braided stainless steel annular convoluted B-Flex hoses have been in use, however, the annular convoluted design has been found to act as a contaminant trap. Although still acceptable for use at present, where practicable to do so (e.g. when a hose requires to be renewed due to damage or leakage) B-Flex hoses should be replaced with smooth bore EN ISO 1825 aviation approved equivalents. For static tanks, connection to the pumping system should be stainless steel pipework.

Pumps

2. Where practicable, systems should be designed to incorporate a twin pump skid in order to provide redundancy should one pump fail in service. The pumps should be manufactured from materials compatible with aviation fuel service and be electrically, hydraulically or pneumatically driven, centrifugal or positive displacement types with a head and flow rate suited to the particular installation. The pump(s) should be able to deliver up to 225 litres (50 imperial gallons) per minute under normal flow conditions. Pump discharge pressure should be set to overcome head loss and equipment pressure drops such that pressure measured at the dispensing cabinet against a closed head does not exceed 50 psi (3.45 bar). In order to provide protection, a pump inlet Y-strainer with 60 mesh (or finer) screen should be fitted. The strainer should be orientated in the vertical plane with the basket pointing downwards so that contaminants settle out of the fuel path. Pot type strainers should not be used as removal of accumulated contaminants is difficult. A remote start/stop control should be provided at the helideck close to the hose storage location (in a position where the operator is able to view the whole fuelling operation). Additionally there should be a local emergency stop control adjacent to the pump(s).

NOTE: Hand pumps for delivery of fuel to an aircraft should not be incorporated in refuelling system designs and should be removed from existing systems where fitted. Lack of use over long periods of time may result in deterioration of the

hand pumps' internal components, causing them to become a potential source of system contamination. However, hand pumps may be used to transfer fuel samples to and from closed circuit samplers and as such, should be manufactured from stainless steel.

Pump and aircraft bonding safety systems.

3. The pumping system should be equipped with an automatically switched, flashing pump-running warning beacon that is visible from the helideck to clearly show that the fuel delivery pumps are running. Ideally, the flashing beacon should be coloured amber to distinguish it from other helideck lighting and to ensure it is visible against the general installation lighting. The colour red should not be used. In addition, there should be an automatic interlock (i.e. an Earth Proving Unit (EPU)) that prevents the pump from running and the pump-running warning flashing until such time as there is positive earth bonding established between the aircraft and the refuelling system. It is important that only approved earth bonding connection points are used for attaching the EPU lead to; the location and type of approved points will vary depending on aircraft make and model. For operational reasons, it should be possible to run the system by earthing the EPU to something other than an aircraft in order to draw daily samples and carry out maintenance activities. The system should be robustly designed to prevent inadvertent disconnection during operation whilst at the same time ensuring 'breakaway device' integrity is maintained as temperamental operation may be a contributing factor to intentional by-pass of aircraft bonding during refuelling operations. In the event of an earth bonding fault occurring, the system should be designed such that 'steady-state' enunciator lights are extinguished at the dispensing cabinet (e.g. at the control panel) and a manual intervention is required prior to re-starting the pump. Although one side of the earth loop will be connected to the control circuit, the electrical resistance between the end connection of the second side of the loop and the system pipework should not be more than 25 ohms. The selected length of cable provided should be consistent with easily reaching the helicopter earth

bonding points when the aircraft is correctly positioned on the helideck. In the event that a helicopter has to lift off quickly, a quick-release mechanism should be provided by fitting a 'breakaway device' into the bonding cable a short distance away from the clamp / pin at the helicopter end.

In the case of existing delivery systems an EPU should be installed. Where this is not practicable, an earth bonding cable should be fitted as detailed in paragraph 7.14, 9.

NOTE: Regardless of the status of the EPU that prevents the pump from running and the pump-running warning beacon flashing, the flight crew/HLO remain responsible for ensuring that the bonding cable has been disconnected from the aircraft and is properly stowed prior to clearance for flight (see also Chapter 8, paragraphs 8.50, 7 and 8).

Flow meter

4. The flow meter should be manufactured from materials compatible with aviation fuel service and ideally be of the positive displacement type due to a greater degree of accuracy attainable, however, other types may be considered where they can be set up to guarantee acceptable accuracy levels for the intended duty; meters should be appropriately sized to suit the system flow rate. Flow meters should be fitted with a read-out in litres and should be positioned upstream of the fuel filter monitor or combined three-stage filter vessel due to the risk of system contamination from potential breakdown or wear of moving parts inside the flow meter body. System designs should take fully into consideration flow meter manufacturers' recommendations including the installation of strainers and air eliminators when appropriate, especially when placed before a combined three-stage filter vessel. In the case of existing systems with flow meters installed downstream from the fuel filter monitor, consideration should be given to relocating the flow meter upstream, where it is practicable to do so. Alternatively, suitable controls (e.g. an additional sample point from the meter body) and procedures should be

put in place to ensure that the system can be routinely monitored for entrained particulate matter.

Filtration

5. System filtration should either consist of a two-vessel design, where first and second stage filtration takes place within a filter water separator vessel and third stage filtration takes place within a fuel filter monitor vessel, or alternatively a single vessel design may be used in the form of a combined three-stage filter vessel. Vessels should comply with the general requirements of EI 1596 'Design and construction of aviation fuel filter vessels' (latest edition) as well as meeting the following criteria:
 - **Filter water separator**
 - Filter water separators should be sized to suit the discharge rate and pressure of the delivery system and be fitted with an automatic air eliminator and pressure relief valve. Units should comply with the latest edition of EI 1581 'Specification and qualification procedures for aviation jet fuel filter/separators' (with reference to Joint Inspection Group (JIG) Aviation Fuel QC Bulletin No. 7). These filters should provide protection down to 1 micron particle size or better.
 - A direct read differential pressure gauge (e.g. Gammon Model GTP-534 series or equivalent) with calibrated reading should be fitted in order to provide a means of monitoring element condition during operation.
 - Filter units should be fitted with a sample line at the lowest point of the vessel to enable contaminants, including coalesced water, to be drained from the unit and to prove cleanliness of the fuel. The connection for the sample line should therefore be after the first stage of filtration (coalescer elements) and before the second stage of filtration (separator element). Vessels may be fitted with additional drain points, but these should generally not be used as sample points in daily use. The sample line should be double valved, with the downstream valve being a

full bore ball valve to prevent trapping of sediment and to allow samples to be taken under full flow conditions in a controlled manner. Where practicable, the downstream valve should have spring return operation as a safety feature. The stainless steel sample line should terminate with a captive dust cap. Sample lines on filter units should be a minimum of 12 mm ($\frac{1}{2}$ " nominal bore but, in general, the larger the diameter of the sample line, the better.

- Where practicable to do so, existing filter vessels/systems should be upgraded to meet the requirements of EI 1581 (latest edition) and JIG Aviation Fuel QC Bulletin No. 7.
- In addition, all filter vessels should be equipped with:
 - Manual sump drains - Valves with handles spring loaded to the closed position are recommended.
 - Placard indicating month and year of last filter change.
- **Fuel filter monitor**
 - A fuel filter monitor should be sized to suit the discharge rate and pressure of the delivery system and be fitted with an automatic air eliminator. The elements should be EI 1583 'Laboratory tests and minimum performance levels for aviation fuel filter monitors' (latest edition) approved and be designed to absorb water still present in the fuel down to 1 ppm and to cut off the flow of fuel if the amount of water in the fuel exceeds an acceptable limit compromising fuel quality. The monitor is described as an Aviation Fuel Filter Monitor with absorbent type elements.
 - A differential pressure gauge with calibrated reading should be fitted in order to provide a means of monitoring element condition during operation.
 - Filter units should be fitted with a stainless steel sample line at the lowest point of the vessel's pre-filtration chamber to enable contaminants to be drained from the unit and to prove cleanliness of the fuel. The sample line should be double

valved with the downstream valve being a full bore ball valve to prevent trapping of sediment and to allow samples to be taken under full flow conditions in a controlled manner. Where practicable, the downstream valve should have spring return operation as a safety feature. The sample line should terminate with a captive dust cap. Sample lines on filter units should be a minimum of 12 mm (½") nominal bore but, in general, the larger the diameter of the sample line, the better.

NOTE: Consideration should be given to equipping the direct reading differential pressure gauge with a pressure limiting device to prevent excessive differential pressure. See JIG bulletin 58 and ATA 103 2-7-2b.1.

- **Combined three-stage filter vessel**
 - Combined three-stage filter vessels should incorporate first-stage coalescer elements, second-stage separator elements and third-stage monitor elements within a single vessel and should be sited adjacent to or within the dispensing cabinet. Vessels should be sized to suit the discharge rate and pressure of the delivery system and be fitted with an automatic air eliminator and pressure relief valve. Units should be in compliance with EI 1581 (to the latest edition with reference to JIG Aviation Fuel QC Bulletin No. 7) and such filters should provide protection down to 1 micron particle size or better. Third-stage monitor elements should comply with EI 1583 (latest addition) and be designed to absorb water still present in the fuel down to 1 ppm and to cut off the flow of fuel if the amount of water in the fuel exceeds an acceptable limit compromising fuel quality.
 - A differential pressure gauge system with calibrated reading (e.g. two PDIs) should be fitted in order to provide an effective means of monitoring the condition of all filtration elements during operation. In order to prevent undetected element rupture or bypass, it is important that 1st stage coalescer and

3rd stage monitor element differential pressure readings are able to be monitored independently from each other.

- Filter units should be fitted with a stainless steel sample line at the lowest point of the vessel to enable contaminants, including coalesced water, to be drained from the unit and to prove cleanliness of the fuel. The connection for the sample line should therefore be after the first stage of filtration (coalescer elements) and before the second stage of filtration (separator element). Vessels may be fitted with additional drain points, but these should generally not be used as sample points in daily use. The sample line should be double valved with the downstream valve being a full bore ball valve to prevent trapping of sediment and to allow samples to be taken under full flow conditions in a controlled manner. Where practicable, the downstream valve should have spring return operation as a safety feature.
- The sample line should terminate with a captive dust cap. Sample lines on filter units should be a minimum 12 mm (½") nominal bore but, in general, the larger the diameter of the sample line, the better.

Closed circuit sampler

6. Fitment of a closed circuit sampler is recommended where sampling is made difficult due to the exposure of manual sample point connections to airborne contaminants such as blown debris or rainfall. A closed circuit sampler should be fitted in addition to, not instead of, manual sample points as a tee-off from the sample line as near to the upstream side of the manual ball valve as possible and can be used for sampling tanks, filter vessels or even pressure refuelling couplings with the right connections fitted. Multiple samplers may be installed, or one sampler can be used for sampling multiple pieces of equipment depending on system layout and if appropriately manifolded. Routing of piping or instrumentation tubing from sample lines to the closed circuit sampler

should keep vertical rises and dog legs to a minimum in order to aid free movement of any contaminants which may be present in the fuel being sampled. As the nominal bore of the entry point connection to closed circuit samplers is generally small ($\frac{3}{8}$ "), piping or instrumentation tubing size is not restricted to the stipulations laid out for tank and filter vessel sample lines and smaller bore instrumentation may be used, although it is recommended that no smaller than 12 mm ($\frac{1}{2}$ ") OD tubing with an nominal bore around 10 mm ($\frac{3}{8}$ ") be used.

Hose reel assembly

7. A robust delivery hose reel should be fitted within the dispensing cabinet to allow correct stowage and protection of the fuel delivery hose. It should be sized to accommodate the length and diameter of hose fitted to the system ensuring that the minimum bend radius of the hose is considered. It is recommended that the reel is of stainless steel construction, however, painted mild steel and aluminium are also acceptable on condition that all wetted metal parts are stainless steel so as not to expose the fuel to potential contamination. It is recommended that an electric or pneumatically powered rewind mechanism is fitted to overcome potential manual handling issues when rewinding the hose. However, a manual rewind facility should also be fitted in case of motor failure. Power rewind reels should be equipped with some form of slip drive (e.g. a slip motor, dead-man's switch, clutch or dead-man's pneumatic valve) to protect against entanglement when rewinding the hose.

Fuel delivery hose

8. The fuel delivery hose should be an approved semi-conducting type to EN ISO 1825:2011 Type C, Grade 2, 38 mm ($1\frac{1}{2}$ ") nominal bore fitted with reusable safety clamp adaptors; hoses of larger diameter may be required if a higher flow rate is specified. The selected length of refuelling hose provided should be consistent with easily reaching the helicopter refuelling points when the aircraft is correctly positioned on the helideck.

Bonding cable

9. Where it is not practicable to fit an aircraft bonding safety system (e.g. an EPU) to existing refuelling systems as detailed in paragraph 1.13, 3 a suitable high visibility bonding cable should be provided to earth the helicopter airframe before any fuelling commences. The cable should be earth-bonded, common to the system pipework at one end, and be fitted with a correct earthing adaptor to attach to the aircraft at the aircraft end. It is important that only approved earth bonding connection points are used for attaching the bonding cable to; the location and type of approved points will vary depending on aircraft make and model. In the event that a helicopter has to lift off quickly, a quick-release mechanism should be provided by fitting a 'breakaway device' into the bonding cable, a short distance away from the clamp at the helicopter end. The electrical resistance between the end connection and the system pipework should not be more than 25 ohms. The selected length of bonding cable provided should be consistent with easily reaching the helicopter refuelling points when the aircraft is correctly positioned on the helideck.

Fuelling nozzle

10. Fuel delivery to the aircraft may be either by gravity (overwing) or pressure (underwing) refuelling. It is operationally advantageous to have the ability to refuel by either means to suit the aircraft type using the helideck:
- **Gravity**
 - The nozzle should be 38 mm (1½") spout diameter fitted with 100 mesh strainer. Suitable types include the EMCO G180-GRTB and Elaflex ZVF 40.3 refuelling nozzle or equivalent.
 - **Pressure**
 - For pressure refuelling the coupling should be 63.5 mm (2½") with 100 mesh strainer and quick disconnect. Suitable types include Carter, Avery Hardoll and Meggitt couplings. Couplings

should be fitted with a regulator/surge control device with a maximum spring rating of 241.3 kPa (35 psi).

NOTE: Although a correctly functioning pressure refuelling coupling surge controller will restrict delivery pressure to the aircraft fuel system to the setting of the surge controller's internal spring, it is not recommended that this be relied upon as the sole means of system pressure regulation.

- **Hose-end adaptor**

- To be able to readily change between pressure and gravity refuelling in order to meet different aircraft type requirements, a self-sealing hose-end adaptor can be fitted to the hose-end and matching actuators fitted to the different nozzles. Suitable types include the Gammon GTP-919. Alternatively, a short length of hose fitted with an aircraft adaptor on one end (to fit to the pressure refuelling coupling) and with the gravity nozzle attached to the other end can be used as required. This arrangement gives the flexibility to provide direct pressure refuelling or, with the extension hose attached, a means of providing gravity refuelling.

Interconnecting pipework

11. Interconnecting pipework (e.g. between refuelling system pump skid and dispensing cabinet) is generally the responsibility of the installation contractor and should be designed and fabricated to suit the duty flow rate requirements of the system; 2" nominal bore piping is most typically used, however, 3" nominal bore may be required to reduce pressure losses dependent on pipe-run length.

Piping material should be 316L or equivalent grade stainless steel as a minimum standard. Higher grades may be selected depending on operating parameters.

Pipework should be fabricated using butt weld / weld neck fittings and full penetration welding. Socket weld fittings should not be used as this can

cause dirt traps. Slip on weld flanges are acceptable where an internal fillet weld can be laid. Pipe-run design should aim to minimise the number of doglegs and low points which could act as accumulation points for contaminants; low points should be fitted with drainage connections. Piping should either remain unpainted or be primed and finished with a suitable paint system to resist the marine operating environment. It is best practice to fit flange to flange earth bonding straps across every flanged connection where there is a flow of fuel in order to dissipate electrostatic charge generated by the movement of fuel, however, as a minimum, earth bonding straps should be fitted when a paint lining is applied ensuring paint is bared back on both sides of one flange bolt hole to allow a metal to metal contact. Flange fixings should be stainless steel, with specifications being dictated by pressure calculations. In special circumstances, it may be necessary to use carbon steel fixings, and in this case, it will also be a mandatory requirement to fit flange earth straps as the carbon steel fixings should be installed with insulation kits (e.g. Maloney kits) to prevent dissimilar metal corrosion and surface pitting of the flanges (e.g. galvanic corrosion). Earth straps will be required to contact the flange surface and insulation kits should be fitted through the earth straps. Gasket material should be selected to meet piping specification requirement but with the caveat in place that system cleanliness should not be compromised. Plain graphite gaskets should under no circumstances be used due to the flake nature of graphite. Likewise, plain CNAF gaskets have been found to shed fibres. Composite material gaskets such as PTFE impregnated CNAF where fibre shed is not an issue are more suitable. If piping specification does require graphite gaskets be used, only gaskets where the graphite is not in contact with the fuel will be acceptable, such as certain types of spiral wound gasket.

Weather protection

12. The delivery system, including hoses and nozzles, should be equipped with adequate weather protection to prevent deterioration of hoses and ingress of dust and water into the nozzles.

Transfer system

- 7.15 Where a static storage tank or tanks are fitted and in use, depending on system layout, it may be possible to utilise the delivery system equipment to transfer fuel from transit tanks into the storage tanks, but if not additional equipment may be required for fuel transfer. This generally consists of:

Transfer pump(s)

1. Where practicable, systems should be designed to incorporate a twin pump skid in order to provide redundancy should one pump fail in-service. This may not always be possible due to space restrictions. The pumps should be manufactured from materials compatible with aviation fuel service and be electrically, hydraulically or pneumatically driven, centrifugal or positive displacement types with a head and flow rate suited to the particular installation. There is no set transfer flow rate requirement however, pumps should not be able to deliver more than the rated flow of the transfer filter vessel. Operation of pumps should be controlled through a local control station. There should be a local emergency stop control adjacent to the pumps.

Transfer flow meter

2. There is no requirement to have a transfer flow meter fitted if fuel quantities transferred can be quantified by other means (e.g. tank calibration chart, accurate level gauge or known 'supplied quantity' and 'break suction quantities'). If a flow meter is fitted, it should be manufactured from materials compatible with aviation fuel service and ideally be of the positive displacement type due to a greater degree of accuracy attainable, however, other types may be considered where they can be set up to

guarantee acceptable accuracy levels for the intended duty; meters should be appropriately sized to suit the transfer flow rate. Flow meters should be fitted with a read-out in litres and should be positioned upstream of transfer filter due to the risk of system contamination from potential breakdown or wear of moving parts inside the flow meter body. System designs should take fully into consideration flow meter manufacturers' recommendations including the installation of strainers and air eliminators when appropriate.

Transfer filtration

3. Transfer filtration should either consist of a filter water separator or a fuel filter monitor. Although it is not recommended or necessary, it is acceptable to fit both a filter water separator and a fuel filter monitor or a combined three-stage filter vessel. Vessels should meet the same criteria as described for delivery system filter vessels.

Transit tanks

- 7.16 Transit tanks should be constructed to satisfy the requirements of Intergovernmental Marine Consultative Organisation (IMCO), International Maritime Dangerous Goods (IMDG) Codes and the latest EU regulations. Current inspection and repair codes of practice are EN12079 and ISO 10855.
- 7.17 Tanks may be constructed from stainless steel or mild steel. If mild steel is used, then the tanks should be lined internally with a suitable white coloured fuel-resistant epoxy lining. External surfaces should be lined with a suitable paint system to resist the marine operating environment and fuel spillage.
- 7.18 The tanks should be encased in a robust steel cage with four main lifting eyes designed and certified to DNV 2.7-1 standard. (It should be noted that use of BS 7072 framed tanks has been prohibited since 1st January 2015 in the UKCS). Where possible, stainless steel fasteners in conjunction with stainless steel fittings should be used. The tank frame

(cage) should incorporate cross-members to provide an integral 'ladder' access to the tank top. When horizontal vessels are mounted in the transit frame there should be a tank centre line slope towards a low point.

Vertical vessels should have dished ends providing adequate drainage towards the tank low point. This slope should be at least 1 in 30, although 1 in 25 is preferred.

7.19 Tanks should be clearly and permanently marked on the identification plate with the tank capacity, IMDG 'T' classification number and tank serial number. Tanks should also be clearly marked with the date of the last lifting gear inspection and initial and most recent IMDG pressure test.

7.20 Tanks should be equipped with the following:

Manhole

1. A 450 mm (18") or greater manhole to allow physical access to the interior of the tank.

Inspection hatch

2. If the manhole position and/or cover type is unsuitable for inspecting the lower end of the tank, a 150 mm (6") hatch should be fitted to enable inspection.

Dipstick connection

3. A suitable access point to allow a dipstick to be used in order to determine the tank contents. A captive dipstick may also be attached to the tank frame or held within the tank vessel.

NOTE: A millimetre dipstick and calibration chart suited to each individual style of tank is required to accurately determine the tank contents at the point of filling and return to shore for Customs & Excise purposes. As access to the top of transportable tanks whilst offshore is largely restricted due to "Working at Height" hazards, fuel stock can most accurately be determined by completion of accurate fuel quality control documentation; fuel usage should be recorded daily to accurately determine the amount of usable fuel remaining in the tank. This will

not be achieved using a level gauge (even most integral (captive) dipsticks are only $\pm 5\%$ accurate) and thus, it will increase the risk of entrained air being delivered into the aircraft fuel tanks.

Emergency pressure relief

4. A stainless steel 63.5 mm (2½") pressure/vacuum relief valve fitted with weatherproof anti-flash cowl. The valve settings will depend on the type of tank in use and manufacturers' recommendations should be followed.

Sample connection

5. A stainless steel sample point, fitted at the lowest point of the tank. A foot-valve should be fitted in the sample line, complete with an extension pipe terminating with a full bore ball valve with a captive dust cap. Sample lines should be a minimum of 19 mm (¾") nominal bore. In order to allow a standard 3-litre sample jar to be used, the sample point should be designed with sufficient access, space and height to accommodate the jars.

Fill/Discharge connection

6. The fill / discharge connection should be a flanged fitting with a 76 mm (3") internal foot valve terminating to a 63.5 mm (2½") self-sealing coupler complete with captive dust cap. The draw point for the tank outlet should be at least 150 mm (6") higher than the lowest point of the tank.

Document container

7. A suitably robust container should be positioned close to the fill/discharge point to hold the tank and fuel certification documents.

Tank barrel and frame external surface finishes

8. The tank barrel and frame should be suitably primed and then finished in safety yellow (BS 4800, Type 08.E.51). Where the barrel is fabricated from stainless steel it may remain unpainted. Safety yellow is not mandatory but has been generally accepted for helifuel tanks. All component parts, e.g. tank, frame etc., should be properly bonded for

earth continuity before being painted and the tank should be fitted with an unpainted bonding pin or plate made from brass or stainless steel.

Whether the tank barrel is painted yellow or otherwise, Jet A-1 Transit Tanks should be correctly identified by placing clear product identification markings on all sides, particularly above the tank fill and discharge connection.

Tank shell internal finish

9. The internal finish should be sufficiently smooth to ensure that liquid run-off is clean and allow the tank to be wiped down during internal inspections without dragging threads or lint from the cleaning cloth. Weld roots should be laid or ground flush with the bottom centre-line of the tank to prevent water or contaminant traps.

Chapter 8

Helicopter fuelling facilities – Maintenance and fuelling procedures

- 8.1 This chapter provides general advice and best practice on the necessary requirements for fuelling system maintenance and the fuelling of helicopters on offshore installations and vessels. It includes recommended procedures for the onshore filling of transit tanks, the transfer of fuel from transit tanks to static storage, the refuelling of aircraft from both transportable and static storage tank systems, static storage tank draining and long term fuel storage.
- 8.2 The management of helicopter fuelling facilities and the associated operations should be formally hazard / risk assessed as part of the organizations Safety Case or Safety Management System. Additionally, safety controls for fuelling facilities and fuel handling, identified through the hazard / risk assessment processes, should be included in the facilities / operators internal Quality Assurance (QA) program.
- 8.3 Fuel storage, handling and quality control are key elements for ensuring, at all times, the safety of aircraft in flight. For this reason, personnel assigned supervisory and operating responsibilities should be certified as properly trained and competent to undertake systems maintenance, inspection and fuelling of aircraft.
- 8.4 This chapter has been prepared by Oil & Gas UK, in consultation with the offshore oil and gas industry and aviation specialists, with the relevant content of [CAP 748 'Aircraft Fuelling and Fuel Installation Management'](#) in mind. However, additional detailed technical information and codes of practice can be obtained from the EI/JIG (Energy Institute and Joint Inspection Group) Standard 1530, EI Aviation Fuel Handling Standards and JIG Standards 1 to 4. Where the reader is referred to other standards or alternative guidance, the reference documents used should always be

checked by the reader to ensure they are up-to-date and reflect current best practice.

- 8.5 Alternative procedures from other recognised national sources may be used where duty holders can satisfy themselves that the alternative is adequate for the purpose, and achieves equivalence, considering particularly the hostile conditions to which the fuelling systems may be subjected and the vital and overriding importance of a supply of clean fuel.
- 8.6 Management and handling of the Jet A-1 fuel supply chain and offshore helicopter fuelling processes requires that **all** personnel involved in the fuel supply chain be fully trained and regularly assessed, by an independent assessor, as competent for these specialist activities.
- 8.7 It is recommended that duty holders refer to Oil & Gas UK Guidelines for the Management of Aviation Operations – Part D Personnel Training & Competence and OPITO Training and Competence Standards for detailed refuelling team training and competence requirements.

Fuel quality sampling and sample retention

- 8.8 Throughout the critical processes of aviation fuel system maintenance and fuelling operations, routine fuel sampling is required to ensure that delivered fuel is scrupulously clean and free from any contamination that may enter the aircraft fuel tanks which could ultimately result in engine malfunctions. The requirement to distinguish between colours during fuel sample testing (e.g. water detector tests) should be taken into account when selecting personnel for this task. The condition of colour blindness could potentially cause erroneous results.

Fuel sample containers

- 8.9 Fuel samples drawn from transit/static storage tanks and the fuel delivery system during daily and weekly tests should be retained in appropriate containers for specified periods. The sample containers should be kept locked in a secure, suitably constructed light-excluding store and kept

away from sunlight until they are disposed of (aviation fuel is affected by UV light).

- 8.10 Only scrupulously clean, standard 3-litre clear glass sampling jars should be used for taking fuel samples unless using a closed circuit sampler. It is strongly recommended that they are also used for initial storage. Supplementary items such as buckets and funnels, fitted with earth cable and clamp, should be manufactured from stainless steel. To prevent sample contamination, sampling jars and all supplementary items should be scrupulously cleaned before each use using lint free cloth. In this context, lint is defined as “short, fine fibres which separate from the surface of cloth”.
- 8.11 It is recommended that the fuel samples are no longer kept in 5-litre International Air Transport Association (IATA) lacquer-lined sample cans because their design prevents scrupulous cleaning and visual confirmation of removal of all sources of contamination (e.g. trace sediments) prior to re-use. Sediments trapped in IATA cans are likely to result in highly inaccurate representations of drawn fuel samples when submitted for laboratory analysis, in the event of an aircraft incident where fuel is a suspected causal factor.
- 8.12 When drawn fuel samples are requested for analysis as evidence, the appropriate samples should be decanted from glass sample jars into unused, purpose-made IATA sample cans for transportation. Sample cans should be conditioned prior to use by subjecting them to a 48 hour soak with uncontaminated fuel in order to remove pigmentation and other surface chemicals from the lacquer lining.

Fuel sampling

- 8.13 Fuel samples taken from any aviation fuelling system sample point should be the correct colour, clear, bright and free from solid matter. They should also be checked for dissolved water by using a syringe and water detector capsule. If a sample does not meet the quality criteria as laid out below, the sample should be disposed of, sampling equipment should be cleaned

and the sampling process repeated until an acceptable result is achieved. However, sampling should not be repeated indefinitely but should take into consideration whether or not sample quality is improving over subsequent attempts as well as the nature of contamination. If consistently unacceptable samples are obtained with little or no improvement (after more than 3 times), it may become necessary to contact the fuel inspection company responsible for certification of the fuelling system.

- 8.14 Filter vessel and hose end samples should be taken under pump pressure. Where a closed circuit sampler is fitted to static storage tank sample points, unless the tanks are sufficiently elevated or the sampler sufficiently lowered, to provide enough head of pressure for filling the sampler at a reasonable rate. If a hand pump is fitted for lifting fuel, it should be used with sufficient force to obtain a reasonable flow of fuel into the closed circuit sampler.
- 8.15 Checking for fuel quality using a manual sample point and 3 litre glass jar should be carried out whilst making observations in the following manner:
- 1) Samples should be drawn into scrupulously clean, clear glass sample jars at full flush (or as close to full flush as is reasonably practicable without causing spillage). The jar lid should be fitted as soon as possible to reduce the likelihood of airborne contamination of the sample.
 - 2) The fuel sample should be visually checked to ensure it is of the correct colour, clear, bright and free from solid matter and dissolved water. (Jet A-1 may vary from colourless to straw colour.)
 - 3) Free water will appear as droplets on the sides, or bulk water on the bottom, of the sample jar. If there is any evidence of free water the sample should be rejected.
 - 4) Suspended water will appear as a cloud or haze, however, small air bubbles may also appear as a haze. Air bubbles can appear in fuel samples from filter vessels for 2 to 3 days following a filter change. If

there is any sign of a haze, the sample should be left for 60 seconds to determine whether or not this indicates presence of air or water; air bubbles will settle out upwards whilst water will either remain, or will settle to the bottom of the jar where the droplets can form together to create free water. If the evidence points towards suspended water, the sample should be rejected. If in doubt, a water detector capsule test will determine the correct outcome.

- 5) Solid matter is usually made up of small amounts of dust, rust, scale etc. suspended in the fuel or settled out on the jar bottom. When testing for solid contaminants, swirl the sample to form a vortex; any dirt present will concentrate at the centre of the vortex making it more readily visible. 'Trace' amounts of sediment are acceptable. If more than a 'trace' of solid matter is detected, the sample should be rejected.
- 6) A 'trace' of solid matter in the context of sediment present in Jet A-1 Aviation Fuel samples is defined as, 2 to 3 particles of debris not exceeding 0.5 mm diameter.
- 7) Testing for dissolved water should be carried out using a syringe and proprietary water detector capsule (e.g. Shell type or an approved alternative). Fit a capsule to the syringe, immerse in the fuel sample and immediately draw a 5 ml fuel sample into the syringe. If the capsule is withdrawn from the fuel and there is less than 5 ml in the syringe, the capsule should be discarded and the test repeated using a new capsule. Examine the capsule for any colour change. If there is any colour change the fuel should be rejected.

NOTE 1: Empty syringe contents slowly with the tip immersed back in the fuel sample. Do not spray the 5ml syringe contents into the atmosphere because this creates a hazardous Jet A-1 explosive mixture.

NOTE 2: The same sampling criteria as set out in 8.13 above should be applied. If consistently unacceptable samples are obtained with little or no improvement, it may become necessary to contact the fuel inspection company responsible for certification of the fuelling system.

- 8.16 Checking for fuel quality using a closed circuit sampler is similar to sampling carried out as described in section 8.13 above and the same pass/fail criteria applied to samples, however, the order in which checks are carried out does vary. Carry out sampling and make observations in the following manner:
- 1) Samples should be drawn into the closed circuit sampler at full flush (or as close to full flush as is reasonably practicable without causing spillage out of the lid). The sampler should have been cleaned prior to filling and the lid should be closed, however, the lid does not form a pressure tight seal.
 - 2) As the fuel enters the jar off-centre, it immediately creates a vortex, therefore any solid contaminants and any free water present will concentrate at the centre of the vortex making it more readily visible. Vortex checks should therefore be carried out first.
 - 3) The fuel should then be allowed to settle until the vortex slows or stops. This will allow colour, appearance and suspended water checks to be carried out.
 - 4) Testing for dissolved water should be carried out as the final test using a syringe and proprietary water detector capsule (e.g. Shell type or an approved alternative). Some closed circuit samplers come equipped with a water detector port on the inlet line, whilst others require the test to be carried out by opening the sampler lid.

- 8.17 Capsules should be kept tightly sealed in their container when not in use. Capsule tubes are marked with the relevant expiry date and capsules should be used before the end of the month shown on the container. Capsules should not be re-used.

NOTE: The use of water-finding paper or paste is no longer recommended. These methods do not meet the minimum standards for detecting water content at the fuel delivery point of 30 ppm (see IATA Guidance Material for Aviation Fuel Specifications).

Fuel sample retention

- 8.18 The purpose of retaining selected fuel samples during the handling processes is to provide proof of fuel quality when delivered to an aircraft.
- 8.19 In the event of an aircraft incident where fuel may be considered to be a causal factor, retained fuel samples will subsequently be requested by the helicopter operator to support technical investigations.
- 8.20 The following table summarises the minimum recommended fuel sampling and retention requirements for offshore helicopter operations.

	Sample	Reason for sampling and when taken	Sample retention period
1	Transit tanks	Filling onshore	Until transit tank is returned onshore
2	Transit tanks	Within 24 hours of placement in a bunded storage area and weekly thereafter until tank becomes next on-line	24 hours
3	Transfer filters	Prior to fuel transfer or weekly, whichever occurs first	When an acceptable clean fuel sample has been obtained, samples can be discarded
4	Transit tanks	Prior to decanting to bulk storage tank or daily when on-line or next in-line	24 hours
5	Static storage tank	Daily - prior to system use	48 hours
6	Delivery filter water separator and filter monitor	Daily - prior to system use	When an acceptable clean fuel sample has been obtained, samples can be discarded
7	Delivery hose end (refuelling nozzle)	Daily - prior to system use	When an acceptable clean fuel sample has been obtained, samples can be discarded or retained as a pre-refuel sample

8	Delivery hose end (or fuel filter monitor if pressure refuelling with no nozzle sampler)	Before aircraft refuelling, this sample to be checked by the pilot	When an acceptable clean fuel sample has been obtained and the flight crew have seen the evidence (vortex / particle check and water test), samples can be discarded
9	Delivery hose end (or fuel filter monitor if pressure refuelling with no nozzle sampler).	Immediately after aircraft refuelling, this sample it to be checked by the pilot	24 hours. However, if the same aircraft is refuelled again on the same day, the previous sample may be discarded and the new one retained
10	Tanks and delivery system	After heavy rainfall, storms, if subject to water/foam deluge on activation of the fire protection system or after snow on tanks is thawing	When taken, these samples replace the ones taken for 4 and 5 above

8.21 Fuel Sample Labelling – The following information should be clearly marked on the retained fuel samples:

- Transit/Static tanks: Tank No. / Date / Time
- Post refuel sample: A/C Reg. / Date / Time

Decanting from sample reclaim tanks

8.22 Before transfer of fuel takes place from a sample reclaim tank to bulk storage, the reclaim tank should be sampled to ensure the fuel is in good condition.

8.23 Any samples taken prior to transfer should not be returned until transfer from the sample reclaim tank to the bulk tank has been completed as this could stir up contaminants on the bottom of the vessel. After each transfer, the residue in the bottom of the vessel should be fully drained and disposed of to allow the recovery tank to be cleaned using lint free cloths.

- 8.24 The transfer filter vessel should also be sampled under pump pressure before the storage tank inlet valve is opened, to ensure that no contamination is present in the filter vessel. Any contaminated samples should be disposed of into a suitable container.

Recommended maintenance schedules

- 8.25 Different elements and components of the helicopter fuelling systems require maintenance at different times, ranging from daily checks of the delivery system up to three yearly checks on static storage tanks.
- 8.26 Particularly in the UK, responsible bodies within the offshore oil and gas and aviation industries have developed maintenance regimes and inspection cycles to suit their specific operations. There may therefore appear to be anomalies between different source guidance on filter element replacement periodicity, hose inspection and replacement periodicity, static storage tank inspection periodicity and bonding lead continuity checks.
- 8.27 The various components of fuelling systems are listed with their recommended servicing requirements in the following paragraphs and tables.

Transit tanks

- 8.28 All transit tanks should be subject to a 'trip inspection' each time the tank is filled and, in addition, their condition should be re-checked weekly. Six-monthly and twelve-monthly inspections should be carried out on all lined carbon steel tanks. For stainless steel tanks, the inspections can be combined at twelve month intervals.

Trip inspection

1. Each time a transit tank is offered for refilling onshore the following items should be checked:

	Items	Activity
1	Tank shell	Visual check for condition. Has the shell suffered any damage since its previous filling?
2	Filling/discharge and sampling points	Visual check for condition, leakage and caps in place.
3	Lifting frame, lugs and four-point sling	Visual check for signs of damage.
4	Tank top fittings	Check for condition, caps in place, dirt free and watertight.
5	Tank identification	Check that serial number, capacity and contents and hazard identification labels are properly displayed.
6	Tank certificate	Ensure internal cleanliness certificate is valid and located in the document container. (See paragraph 8.60.) Ensure lifting equipment and IMDG pressure testing certification is in date and tank data plates are hard stamped accordingly.

‘On receipt’ inspection

- On receipt of a tank offshore, the following checks should be carried out as the responsibility of the HLO, although tasks may be delegated.

	Items	Activity
1	Custom’s seals	Check that custom’s seals are intact on all points of entry to, or exit from, the tank interior. Are there any signs that the contents have been tampered with?
2	Tank shell	Check for any evidence of damage, i.e. dents or deep scoring. Report any damage as dents may mean damage to the internal paint lining of carbon steel tanks.
3	Tank fill/discharge and sample valves	Check for damage, run finger around flanges and threaded connections for any signs of fuel leakage. Check dust caps or plugs are in place.
4	Tank lifting gear	Check lifting lugs, slings and shackles for signs of damage, check split pins are in place.

5	Tank top fittings	Check all fittings are in place, clean and all dust caps are fitted. Check valves are closed and inspection hatches tightened down.
6	Tank labels	Check that tank identification and serial number (if different) are clearly visible as well as tank capacity. Check that “Jet A-1”, “Flammable UN 1863” and “Marine Pollutant” stickers are in place and that the tank capacity is visible.

Weekly inspection

3. Each transit tank whether it is full or empty, onshore or offshore, should be given a weekly inspection similar to the ‘On Receipt’ inspection as above to ensure that the tank remains serviceable and fit for purpose. The weekly inspection should primarily be for damage and leakage; it may not be possible to check custom’s seals integrity if the tank is in use. The completion of this check should be signed for on the Serviceability Report (see paragraph 8.60).

Six-monthly and twelve-monthly inspection

4. The six-monthly and twelve-monthly inspections should be carried out onshore by a specialist organisation. The scope of the two inspections is identical and should include:

	Items	Activity
1	Tank identification plate	Check details.
2	Tank shell	Visual check for damage.
3	Paint condition (external)	Check for deterioration.
4	Paint condition (internal)	Check for deterioration, particularly around seams if applicable.
5	Lining materials (if applicable)	Check for deterioration, lifting, etc. Acetone test should be carried out on any lining repairs.
6	Tank fittings (internal)	Check condition.

7	Tank fittings (external)	Check condition.
8	Access manhole	Check security.
9	Pressure and vacuum relief valves	Check condition and presence of fire-screen gauze; in particular check for leaks.
10	Dipstick assembly	Check constraint, markings and cover/cap for security (where fitted).
11	Bursting disc	Modern tanks are not fitted with busting discs. Tanks found to have a bursting disc should be modified to incorporate a relief valve.
12	Inspection hatch assembly	Check lid, seal and swing-bolt condition and security.
13	Bonding	Measure electrical bonding resistance between transit tank frame and shell.
14	General	Examination and test procedures to conform with current rules and industry standards.

Re-certification

5. It is a legal requirement that “single product” transit tanks are re-certified at least every 5 years by an authorised specialist, normally the Fuel Inspection Company functioning under an approved verification scheme. There should also be an intermediate check carried out every 2½ years. These checks should include re-certification of the pressure/vacuum relief valve. The date of the re-certification should be stamped on the tank inspection plate.

Static storage tanks

- 8.29 Static storage tanks are subject to an annual or biennial inspection depending on the type of tank. If the storage tank is mild steel with a lining then it should be inspected at least once per year. If the tank is stainless steel then a two-year interval between inspections is acceptable, however, where a track record of minimal findings during internal inspections can be evidenced, inspection intervals may be extended to three years for both

mild and stainless steel tanks at the discretion of the third party fuel Inspection Company. If excessive accumulation of contaminants or degradation of internal surfaces is found following extension to a three-yearly frequency, the inspection frequency should be reverted to biennial or annual as required.

8.30 When due for inspection the tank should be drained and vented with the manhole access cover removed.

8.31 The inspection should include the following:

No.	Items	Activity
1	Cleanliness	Clean tank bottom as required.
2	Tank internal fittings	Check condition.
3	Lining material (if applicable)	Acetone test (note this check need only be carried out on new or repaired linings).
4	Paint condition	Check for deterioration, particularly around seams.
5	Access to tank top fittings	Check condition of access ladder/platform.
6	Inspection hatch	Check lid, seal and swing-bolt condition and security.
7	Access manhole cover	Check lid, seal and swing-bolt condition and refit cover securely.
8	Pressure and vacuum relief valve	Check condition and presence of fire-screen gauze, in particular check for leaks.
9	Floating suction	Check condition, continuity of bonding and operation. Ensure float is empty.
10	Valves	Check condition, operation and material.
11	Sump/drain line	Check condition operation and material.
12	Grade identification	Ensure regulation Jet A-1 markings are applied and clearly visible.
13	Contents gauge	Check condition and operation.

14	Bonding	Measure electrical bonding resistance between tank and system pipework.
----	---------	---

Delivery systems

8.32 The offshore delivery system should normally be inspected every three months by a fuel inspection company, contracted by the offshore asset owner or duty holder to inspect and certify the system is fit for uplifting fuel by the helicopter operator.

NOTE: Inspection in this context is **not** to be confused with Auditing. It is physical intervention / trades supervision by a fully trained and competent engineer for determining condition and replacement of key system components, prior to certifying the system is fit for purpose.

8.33 The function of fuel inspection is twofold; firstly, it allows necessary scheduled invasive and specialist work-scopes to be carried out by an approved engineer, and secondly, it provides system certification on completion of a successful inspection.

8.34 No system should exceed four months between successive inspections and certification may be withdrawn if the system is not maintained in accordance with the requirements noted below.

8.35 The system should be subject to daily and weekly checks by offshore fuelling personnel to ensure sustained operability and satisfactory fuel quality.

Daily checks

1. The following checks should be carried out each day and is the responsibility of the HLO, although tasks may be delegated to another competent person.

	Items	Activity
1	Filter water separator and fuel filter monitor	Drain the fuel from the sump/sample line until it is clear. The sample taken should be checked and retained as noted in paragraph 8.20. NOTE: This check excludes the transfer filter which should be checked weekly or prior to use, whichever is the sooner. This can only be carried out when fuel is being transferred.
2	Transit tank/storage tank	A fuel sample should be drawn from each compartment of the transit tank/storage tank (as applicable) and checked for quality as noted in paragraphs 8.13 and 8.16.
3	Floating suction	The floating suction assembly should be checked for buoyancy and freedom of movement.
4	Delivery hose end (refuelling nozzle)	A sample should be drawn from the hose end and checked for quality as noted in paragraphs 8.13 and 8.16.
5	General system checks	Check for signs of leakage from the system. Ensure that all dispensing equipment is stowed inside the dispensing cabinet with the door closed for protection from the elements when not in use.
6	Complete documentation	Daily checks should be recorded on the 'Daily Storage Check' quality control documentation.

Weekly checks

2. In addition to the daily checks specified in paragraph 1 above the following checks should be carried out each week and is the responsibility of the HLO, although tasks may be delegated to another competent person.

	Items	Activity
1	Transit tanks	Carry out weekly tank checks as detailed in paragraph 8.28.3.

2	Suction hose and hose coupling	<p><i>For EN ISO 1825 rubber hoses:</i></p> <ul style="list-style-type: none"> ▪ Lay out straight to allow the hose to be examined along its length for damage i.e. “soft spots”, bulges, blistering, cuts, abrasions, kinks or crushing. Light surface damage is acceptable, however, no white canvas braiding should be visible through the skin of the hose. ▪ Check hose end clamps for security. <p><i>For B-Flex annular convoluted hoses:</i></p> <ul style="list-style-type: none"> ▪ Check hose has not been coiled too tightly. ▪ Check condition of outer protective cover where fitted. ▪ Feel along hose length checking for crush damage. <p><i>General checks:</i></p> <ul style="list-style-type: none"> ▪ Check complete assembly for any indication of leakage. ▪ Check correct operation of hose coupling. ▪ Check captive dust plug is present.
3	Static storage tanks	<p>Check all tank top fittings are in place, clean and all dust caps are fitted.</p> <p>Check that valves are closed and inspection hatches tightened down.</p>
4	Pump skid/cabinet	<p>Check pump bearings are adequately greased.</p> <p><i>For air motor driven systems:</i></p> <ul style="list-style-type: none"> ▪ Ensure air-line lubricators are adequately topped up with suitable oil and drain air- line water traps. <p><i>For electric motor driven systems:</i></p> <ul style="list-style-type: none"> ▪ Check pump drive gearbox oil level and top up as required.
5	Differential pressure gauges	<p><i>For delivery filter vessels:</i></p> <ul style="list-style-type: none"> ▪ Obtain weekly differential pressure readings for each vessel during refuelling under full flow conditions. If no refuel has taken place during any given week, a sufficient quantity of fuel should be run off into a drum at full flow to allow

		<p>readings to be taken. Readings should be recorded on the 'Filter Record' quality control documentation sheets.</p> <p><i>For transfer filter vessels:</i></p> <ul style="list-style-type: none"> Obtain weekly differential pressure readings for each vessel during static storage tank replenishment under full flow conditions. If no replenishment has taken place during any given week no further action is necessary and readings can be taken during the next replenishment. Readings should be recorded on the 'Filter Record' quality control documentation.
6	Dispensing cabinet pressure gauge	Check for correct operation of the dispensing system fuel pressure gauge.
7	Hose reel	<p>Check rewind gears are adequately greased – apply grease as required.</p> <p>Ensure air-line lubricators for air driven rewind motors are adequately topped up with suitable oil and drain air-line water traps (as appropriate).</p>
8	Fuel delivery hose	<p>Unwind from the hose reel onto the helideck and subject to pump pressure then examine along its length for damage i.e. "soft spots", bulges, blistering, cuts, abrasions, kinks or crushing. Light surface damage is acceptable, however, no white canvas braiding should be visible through the skin of the hose. Particular attention should be paid to those sections of the hose within approximately 45 cm (18") of couplings since they are especially prone to deterioration.</p> <p>Check hose end clamps for security.</p> <p>Rewind hose back onto the reel.</p> <p>Test results to be recorded on the 'Hose Inspection Record' quality control documentation.</p>
9	Fuel delivery nozzles	Inspect for general condition, cleanliness and correct operation to ensure correct lock off and no leakages

		<p>Remove, inspect and clean cone strainers as necessary. If significant quantities of contaminants are found, the reason should be established and remedial action taken.</p> <p>Re-install or renew strainers as required, taking care to locate the seals correctly.</p> <p>Ensure dust caps are present and secure.</p> <p>NOTE: No lubrication except petroleum jelly should be applied to any of the pressure refuelling coupling or gravity nozzle parts</p>
10	Spill pot	Accumulated fuel should be drained from the spill pot and disposed of.
11	Earth bonding/EPU	<p><i>Check for general condition, security and electrical continuity (maximum permissible reading of 25 ohms) on the following earth bonding equipment:</i></p> <ul style="list-style-type: none"> ▪ Tank earth leads and clamps. ▪ Refuelling nozzle ground wires, jack plugs and clips. ▪ Main aircraft bonding/EPU lead, quick release connection and clamp/pin. <p><i>Carry out checks for correct function of the following:</i></p> <ul style="list-style-type: none"> ▪ Main aircraft bonding/EPU reel automatic or manual rewind mechanism. ▪ Main aircraft bonding/EPU quick release connection.
12	General system checks	<p>The system should be checked for leaks and general appearance.</p> <p>Painted components should be visually inspected to determine condition of paint linings. Localised repairs should be carried out where fuel quality and system integrity will not be compromised.</p> <p>Ensure good housekeeping is maintained. Blocked drains, standing water and accumulation of rubbish such as used water detector capsules should be addressed by the HLO or delegate as soon as is achievable.</p>
13	Documentation	Completion of aforementioned checks should be recorded within system QC Documentation.

Three-monthly inspection

3. A three-monthly inspection is the foundation on which the more in-depth six-monthly and annual inspection work scopes are based. Three-monthly inspection work scopes should only be carried out by an authorised Fuel Inspector and will vary dependent on the particular installation and fuel system set up.

NOTE 1: An authorised Fuel Inspector is defined as an individual that is independent from the business unit procuring the inspection service. Inspectors should be technically qualified and competent and be able to demonstrate they have relevant experience on the offshore refuelling systems, components and equipment subjected to examination and verification.

NOTE 2: On some installations, duty holders may require specific work activities to be undertaken by an on-board maintenance team member (e.g. an electrician and / or mechanic) as part of the maintenance management plan. In such cases, the work undertaken by the duty holder should not include activities for breaking into system fuel containment, without receipt of written approval from the authorised / certifying Fuel Inspection Company. Any work done may additionally require inspection and verification following completion.

The following checklist is included as a general guide only, but should cover most equipment scenarios. Additional items may be included when considered appropriate.

	Items	Activity
1	Transit tanks	Carry out weekly tank checks as detailed in paragraph 8.28.3.
2	Suction hose and hose coupling	<p><i>For EN ISO 1825 rubber hoses:</i></p> <ul style="list-style-type: none"> ▪ Lay out straight to allow the hose to be examined along its length for damage i.e. “soft spots”, bulges, blistering, cuts, abrasions, kinks or crushing. Light surface damage is acceptable, however, no white canvas braiding should be visible through the skin of the hose.

		<ul style="list-style-type: none"> ▪ Check hose end clamps for security. <p><i>For B-Flex annular convoluted hoses:</i></p> <ul style="list-style-type: none"> ▪ Check hose has not been coiled too tightly. ▪ Check condition of outer protective cover where fitted. ▪ Feel along hose length checking for crush damage. <p><i>General checks:</i></p> <ul style="list-style-type: none"> ▪ Check complete assembly for any indication of leakage. ▪ Check correct operation of hose coupling. ▪ Check captive dust plug is present.
3	Static storage tanks	<p>Check all tank top fittings are in place, clean and all dust caps are fitted.</p> <p>Check that valves are closed and inspection hatches tightened down.</p>
4	Pump skid/cabinet	<p>Remove, clean and inspect Y-strainer baskets. Where a track record of minimal findings during previous inspections can be evidenced, inspection intervals may be extended to six months at the discretion of the third party fuel inspection company. If an excessive accumulation of contaminants are found following extension to a six-monthly frequency, the inspection frequency should be reverted to three-monthly as required.</p> <p>Check pump bearings are adequately greased.</p> <p><i>For air motor driven systems:</i></p> <ul style="list-style-type: none"> ▪ Ensure air line lubricators are adequately topped up with suitable oil and drain air line water traps. ▪ Check air line lubricator drip feed rate is set correctly. <p><i>For electric motor driven systems:</i></p> <ul style="list-style-type: none"> ▪ Check pump drive gearbox oil level and top up as required.
5	All filtration units (e.g. transfer and delivery)	<p>Check vessels for condition, security of fittings, evidence of leakage and correct product identification labels.</p> <p>Obtain a fuel sample from each filtration unit and perform fuel quality checks as noted in paragraphs 8.13 and 8.16. Note results of the sample checks on system QC documentation.</p>

	filter vessels)	<p>If consistently unacceptable samples are evident during the three-monthly check it could indicate the presence of bacteriological growth in the vessel. This will require the following action to be taken:</p> <ul style="list-style-type: none"> ▪ Open the filter vessel and inspect for surfactants, bacteriological presence, mechanical damage and condition of lining (as applicable). ▪ Clean out any sediment and carry out a water test on the water separator element (as applicable). ▪ Inspect the coalescer/monitor elements (as applicable) and renew as necessary. ▪ Reassemble and repeat testing.
6	Differential pressure gauges	<p>Check condition and security of gauges.</p> <p>Check for correct operation during functional testing and check for full scale deflection and return to 'zero' where gauges have been set up with test valves.</p> <p><i>For delivery filter vessels:</i></p> <ul style="list-style-type: none"> ▪ Obtain weekly differential pressure readings for each vessel during refuelling under full flow conditions. If no refuel has taken place during any given week, a sufficient quantity of fuel should be run off into a drum at full flow to allow readings to be taken. Readings should be recorded on the 'Filter Record' quality control documentation sheets. <p><i>For transfer filter vessels:</i></p> <ul style="list-style-type: none"> ▪ Obtain weekly differential pressure readings for each vessel during static storage tank replenishment under full flow conditions. If no replenishment has taken place during any given week no further action is necessary and readings can be taken during the next replenishment. Readings should be recorded on the 'Filter Record' quality control documentation.
7	Automatic air eliminators	<p>Prime and check for correct operation of all installed air eliminators. If a manual air vent valve is fitted, replace it with an automatic type.</p>

8	System pressure relief valves	Visually check for condition and note certification frequency and due dates on the system inspection report.
9	Dispensing cabinet pressure gauge	Check for correct operation of the dispensing system fuel pressure gauge.
10	Hose reel	<p>Ensure reel rewind mechanism operates correctly by testing operation using powered and manual rewinds (as appropriate).</p> <p>Check bearings and rewind gears are adequately greased – apply grease as required.</p> <p>Ensure air-line lubricators for air driven rewind motors are adequately topped up with suitable oil and drain air-line water traps (as appropriate).</p> <p>Check air-line lubricator drip feed rate is set correctly (as appropriate).</p> <p>Inspect inlet swivel and swan neck hose connection for condition.</p>
11	Fuel delivery hose	<p>Unwind from the hose reel onto the helideck and subject to pump pressure then examine along its length for damage i.e. “soft spots”, bulges, blistering, cuts, abrasions, kinks or crushing. Light surface damage is acceptable; however, no white canvas braiding should be visible through the skin of the hose. Particular attention should be paid to those sections of the hose within approximately 45 cm (18”) of couplings since they are especially prone to deterioration.</p> <p>Check hose end clamps for security.</p> <p>Rewind hose back onto the reel.</p> <p>Test results to be recorded on the ‘Hose Inspection Record’ quality control documentation.</p>
12	Fuel delivery nozzles	<p>Inspect for general condition, cleanliness and correct operation to ensure correct lock off and no leakages.</p> <p>Remove, inspect and clean cone strainers as necessary. If significant quantities of contaminants are found, the reason should be established and remedial action taken.</p>

		<p>Re-install or renew strainers as required, taking care to locate the seals correctly.</p> <p>Ensure dust caps are present and secure.</p> <p>NOTE: No lubrication except petroleum jelly should be applied to any of the pressure refuelling coupling or gravity nozzle parts.</p>
13	Spill pot	Accumulated fuel should be drained from the spill pot and disposed of.
14	Earth bonding/ EPU	<p><i>Check for general condition, security and electrical continuity (maximum permissible reading of 25 ohms) on the following earth bonding equipment:</i></p> <ul style="list-style-type: none"> ▪ Tank earth leads and clamps. ▪ Refuelling nozzle ground wires, jack plugs and clips. ▪ Main aircraft bonding/EPU lead, quick release connection and clamp/pin. <p><i>Carry out checks for correct function of the following:</i></p> <ul style="list-style-type: none"> ▪ Main aircraft bonding/EPU reel automatic or manual rewind mechanism. ▪ Main aircraft bonding/EPU quick release connection.
15	General system checks	<p>The system should be checked for leaks and general appearance.</p> <p>Painted components should be visually inspected to determine condition of paint linings. Localised repairs should be carried out where fuel quality and system integrity will not be compromised.</p> <p>Ensure good housekeeping is maintained. Blocked drains, standing water and accumulation of rubbish such as used water detector capsules should be addressed by the HLO or delegate as soon as is achievable.</p>
16	Documentation	Completion of aforementioned checks should be recorded within system QC Documentation.

Six-monthly inspection

4. Six-monthly inspections should be carried out only by an authorised Fuel Inspector. The content of a six-monthly inspection should include all of the

three-monthly inspection checks detailed in paragraph c above and, in addition, should include the following items:

NOTE: On some installations, duty holders may require specific work activities to be undertaken by an on-board maintenance team member (e.g. an electrician and / or mechanic) as part of the maintenance management plan. In such cases, work undertaken by the duty holder should not include activities for breaking into system fuel containment, without receipt of written approval from the authorised / certifying Fuel Inspection Company. Any work done may additionally require inspection and verification following completion.

	Items	Activity
1	Pump skid/cabinet	<p>Check coupling between motor and pump for wear and signs of misalignment.</p> <p>Refer to refuel system supplier / pump manufacturer's recommended maintenance schedule for additional items.</p> <p><i>For electric motor driven systems:</i></p> <ul style="list-style-type: none"> ▪ All electrical circuits to be checked by a qualified electrician.
2	Interconnecting pipework	Check for clear fuel grade identification labelling in accordance with EI 1542.
3	Flow Meter	<p>Lubricate the meter register head, drive and calibration gears with petroleum jelly.</p> <p>Remove, inspect and clean strainer basket as necessary. If significant quantities of contaminants are found, the reason should be established and remedial action taken.</p> <p>Re-install or renew strainer as required, taking care to locate the seals correctly.</p>
4	Hose reel	Check tension on chain drive and adjust if necessary.
5	Documentation	Completion of aforementioned checks should be recorded within the QC Documentation.
6	Pump skid/cabinet	Check coupling between motor and pump for wear and signs of misalignment.

	<p>Refer to refuel system supplier / pump manufacturer's recommended maintenance schedule for additional items.</p> <p><i>For electric motor driven systems:</i></p> <ul style="list-style-type: none"> ▪ All electrical circuits to be checked by a qualified electrician.
--	--

Annual inspection

5. Annual inspections should be carried out by an authorised Fuel Inspector. The content of the annual inspection includes all the items in both the three-monthly and six-monthly inspections and the following additional items:

NOTE: On some installations, duty holders may require specific work activities to be undertaken by an on-board maintenance team member (e.g. an electrician and / or mechanic) as part of the maintenance management plan. In such cases, work undertaken by the duty holder should not include activities for breaking into system fuel containment, without receipt of written approval from the authorised / certifying Fuel Inspection Company. Any work done may additionally require inspection and verification following completion.

	Items	Activity
1	All filtration units (e.g. transfer and delivery filter vessels)	<p>NOTE: For onshore installations, filter elements need only be replaced "on condition" or every three years. For offshore installations filter elements should be replaced annually</p> <p>Drain down and open filter vessels.</p> <p>Remove, inspect then discard existing disposable type elements (i.e. coalescer and monitor elements). Remove, inspect and carry out water test on separator element if fitted. Satisfactorily inspected and tested separator elements should then be bagged for re-fitment on completion of cleaning.</p> <p>Clean vessel internal surfaces, base plates and manifolds. For lined vessels, check all areas of lining for signs of deterioration.</p> <p>Carry out lining repairs as necessary. Conduct acetone, DfT thickness and/or pin hole detection test on vessel interior linings if applicable.</p>

		<p>NOTE: These need only be carried out to check for correct curing when lining is new or has been repaired.</p> <p>Fit new disposable elements.</p> <p>Fit tested separator element or renew as required (if fitted).</p> <p>Fit new head gasket / seal, close up the vessel and tighten the head securing bolts.</p> <p>Mark the filter body with the dates of the filter element change.</p>
2	Delivery hose	<p>Ascertain when the hose was fitted from system records.</p> <p>Delivery hoses should be pressure tested and recertified (ISO 1825) every two years. However, for operational expediency, duty holders may elect to replace the hose at the prescribed interval or earlier if any defects are found which cannot be repaired.</p> <p>In the absence of facilities for offshore testing, a removed hose should be tested and re-certified onshore.</p> <p>The hose will have a ten-year life from date of manufacture.</p>

Miscellaneous inspection frequency

6. Inspection of some items of equipment within the fuelling system fall out-with standard frequencies. This may be because of individual component manufacturer's recommendations or over-riding platform or vessel standards as examples. Generally, where there is a conflict in inspection frequency, it is preferred that the more stringent standard is adopted. The inspection scopes listed below should be carried out by an authorised Fuel Inspector:

	Items	Activity
1	Pressure relief valves	<p>Change-out or recertification frequency for relief valves fitted to filter vessels, static storage tanks, pipework or other equipment is often dictated by installation specific standards.</p> <p>Relief valves fitted to transit tanks are always managed under IMDG test requirements, i.e. 2½ year frequency.</p>

		<p>Relief valves may be included in a general installation relief valve register but should only be changed out by an authorised third party Fuel Inspector.</p> <p>Wherever possible relief valve change-out should be aligned with scheduled invasive work on the equipment to which it is fitted (e.g. filter change or static storage tank internal inspection).</p>
2	Flow meter	<p>Flow meters may be included in a general installation instrumentation register but should only be changed out by an authorised Fuel Inspector.</p> <p>The flow meter calibration frequency should be in accordance with the manufacturer recommendations. This may be based on elapsed time or throughput.</p> <p>If there is evidence of inaccuracy such as metered quantities not aligning with aircraft instrument readings, investigation and / or rectification / calibration may need to be completed out-with the manufacturer recommendations.</p>
3	Gauges and instrumentation	<p>Pressure and differential pressure gauge calibration or replacement frequencies may be based on gauge type, criticality, manufacturer or operator requirements.</p>

System breakdown

8.36 In the event of a system breakdown, as a general rule, before carrying out 'in-house' repairs on fuelling system equipment, the HLO or his delegate should consult with the issuer of the current system certification to discuss the symptoms of the problem and to seek advice and permission before carrying out any work in order to maintain third party certification of the system. Some work scopes will be permissible following a brief discussion, others will be permissible if carried out by following written instructions or procedures and still others will not be permissible as an in-house repair at all, requiring the mobilisation of an authorised Fuel Inspector.

- 8.37 In general terms, rectification work which does not have a direct effect on fuel quality and is not classed as invasive to the fuel side of the system may be undertaken by the HLO or his delegate following confirmation from the system certification issuer. Some examples of this would be:
- External paint lining repairs,
 - Pneumatic and electrical controls and circuits and earth bonding,
 - Motor and gearbox work,
 - Structural work (roller doors, pipe support brackets, equipment mounting brackets).
- 8.38 Rectification work that has a direct effect or the potential to have a direct effect on fuel quality and other invasive work should not be attempted by the HLO or his delegate unless given specific written permission to do so by the system certification issuer. Some examples of this would be:
- Filter changes or filter contamination investigative work,
 - Pump replacement,
 - Relief valve change-out or recertification,
 - Hose change-out,
 - Static storage tank entry.
- 8.39 Exceptions to this might be where a pump is to be removed for maintenance, but will not be reinstated until a Fuel Inspector is mobilised or where a static storage tank is to be decommissioned. Individual scenarios should be reviewed and the safest course of action determined by the system certification issuer.

Sample reclaim tanks

- 8.40 On a quarterly basis product reclamation tanks should be visually inspected for cleanliness or pass a microbiological growth test, as recommended, by the affected fuel supplier. Clean as required.

Transit tanks

8.41 On a quarterly basis product reclamation tanks should be visually inspected for cleanliness or pass a microbiological growth test, as recommended, by the affected fuel supplier. Clean as required.

Filling of transit tanks

8.42 A 'trip inspection' should be carried out as specified in paragraph 8.28 on return to the tank filling depot. The tank should then be dipped to ascertain the quantity of fuel in the tank in order to calculate the volume of fuel required to fill the tank. Assuming the tank is in serviceable condition, the following actions should then be completed:

- 1) Draw fuel from transit tank sample line and discard until the samples appear free from water and solid contaminants.
- 2) Carry out fuel quality check as noted in paragraphs 8.13 and 8.16.
- 3) Once satisfied that the fuel is free from free and dissolved water, draw off sufficient fuel to measure its specific gravity with a clean hydrometer. The fuel temperature should also be noted in order to correct the measured specific gravity to a relative density (RD) using a correction chart.
- 4) The RD of the fuel sample taken from the transit tank should be compared with that of the previous recorded RD after the last tank filling. The RD of the previous batch of fuel should be taken from the previous release note or from the label on the retained sample. If the difference in relative densities exceeds 3.0kg/m^3 the contents of the transit tank may have been contaminated with some other product refilling should not take place and the contents of the tank may need to be disposed of.
- 5) Assuming the RD of the returned fuel is within specification, connect the bonding wire to the transit tank then connect the delivery hose coupling to the tank filling point and start the transfer pump to fill the tank. When the meter register head indicates that the required quantity of fuel has been transferred, stop the transfer pump, remove

the coupling from the tank and then remove the bonding connection. The dust cap should then be replaced on the filling point.

- 6) Leave the tank to settle for ten minutes. A further sample should be drawn from the tank once it has been filled. The sample should be subjected to a RD check following the same process given in paragraph 4 and the density should be within 3.0kg/m^3 of the composite RD of the bulk tank contents and transit tank residue. This sample should be transferred to a retention can which should be labelled with the tank number, the fuel batch number, date of filling and measured RD. The sample should then be retained safely until the tank is offered again for refilling in order to continue the fuel traceability. This fuel sample will be required as a proof of fuel quality in the event of an aircraft incident where fuel may be considered to be a causal factor.
- 7) The tank should then be sealed to prevent tampering and a release note completed with all the required particulars; special attention should be paid that the correct grade of fuel is included on this release note.
- 8) A copy of the release note should be secured in the tank document container and a further copy retained for reference.

Receipt of transit tanks offshore

8.43 Transit tanks transported offshore are often exposed to sea spray and harsh weather conditions on supply vessels and this could potentially cause ingress of water into the fuel. It is strongly recommended that fuel sampling is carried out as soon as the appropriate settling time has elapsed or at least within 24 hours of the tank being placed into a bunded storage area on the installation or vessel. Settling times are one hour per foot depth of fuel in the tank.

8.44 The following procedure should then be followed:

- 1) Check transit tank seals are still intact.

- 2) Check transit tank fuel grade markings match the fuel grade stated on the fuel release certificate.
- 3) Check tank shell for damage, particularly around welded seams.
- 4) Check fuel release certificate for the following:
 - a) correct grade,
 - b) quantity,
 - c) batch number.
 - d) date filled
 - e) certified free from solid contaminants and water; and
 - f) signed by authorised product inspector.
- 5) Take fuel samples from the transit tank and discard until the samples appear free from water as indicated in paragraph 8.13.

Decanting from transit tanks to static storage

- 8.45 Before commencing any transfer of fuel it is necessary to check the static storage tank fuel level using a dipstick, dip tape or level gauge to ensure that the contents of the transit tank can be accommodated.
- 8.46 The transit tank should have had sufficient time to settle once positioned correctly for the transfer operation. Settling times are one hour per foot depth of fuel in the tank.
- 8.47 Static storage tanks equipped with a floating suction device need at least one hour for settling time and tanks without floating suction should be left for a period in hours approximately equal to the depth of fuel in feet.
- 8.48 The following procedure should then be followed:
- 1) Connect an earth bonding lead to the transit tank.
 - 2) Carry out checks for fuel quality as described in paragraph 8.13.
 - 3) Once a satisfactory sample has been obtained, the suction hose should be connected to the transit tank discharge point and the tank foot valve should be opened.
 - 4) With the system valves set up to supply fuel from the transit tank to the transfer pump and on to the transfer filter vessel, the transfer

pump should be run in order to obtain a sample from the transfer filter vessel under full flow conditions until a satisfactory result is obtained. Stop the pump between samples.

- 5) Re-start the transfer pump and open the static storage tank inlet valve to start the fuel flow. Once fuel transfer has commenced check the coupling connections for any signs of leakage and continue to monitor the fuel flow whilst transfer is taking place.
- 6) When sufficient fuel has been transferred, shut off the valves and stop the transfer pump.
- 7) Disconnect the transfer hose followed by the earth bonding lead and replace any dust caps that were removed at the commencement of the operation.
- 8) Record fuel quality checks and the transfer of the transit tank contents into the storage tanks and retain the fuel release certificate on board the installation/vessel.
- 9) After transfer of fuel into the bulk storage tank and before it is released for use, ensure that the fuel is allowed to settle in accordance with the time periods set out above.
- 10) For systems which are set up to gravity decant fuel from transit to static storage tanks, the process should be identical with the exception of having to operate a pump, i.e. after tank sampling, connect the suction hose and open valves to allow transfer filter sampling under head of pressure of the tank. Once a satisfactory sample is obtained, open the static storage tank inlet valves to commence decant.

Set-up for fuelling direct from transit tanks

8.49 Many offshore helicopter fuelling systems are designed to supply aviation fuel direct from the transit tanks into the delivery system.

8.50 In this case the following procedure should be followed:

- 1) Once the transit tank is located in the tank laydown area and before it is released for use, ensure that the fuel is allowed sufficient time to

settle in accordance with the following time periods. Settling times are one hour per foot depth of fuel in the tank.

- 2) Connect an earth bonding lead to the transit tank.
- 3) Take fuel samples from the transit tank and discard until the samples appear free from water and solid contaminants.
- 4) Carry out checks for fuel quality as described in paragraph 8.13.
- 5) Once a satisfactory sample has been obtained the suction hose should be connected to the transit tank discharge point and the tank foot valve should be opened.
- 6) With the system valves set up to supply fuel from the transit tank to the delivery pump and on to the delivery filter vessels, the delivery pump should be run in order obtain a sample from the delivery filter water separator and, fuel filter monitor or combined three-stage vessel followed by the hose end until a satisfactory result is obtained from each. Stop the pump between samples. Record fuel quality checks, sample quantities taken and retain the fuel release certificate on board the installation/vessel.
- 7) With the system valves set up to supply fuel from the transit tank to the delivery pump and on to the delivery filter vessels, the delivery pump should be run in order obtain a sample from the delivery filter water separator and, fuel filter monitor or combined three-stage vessel followed by the hose end until a satisfactory result is obtained from each. Stop the pump between samples. Record fuel quality checks, sample quantities taken and retain the fuel release certificate on board the installation/vessel.
- 8) The system is now ready for fuelling an aircraft.

Set-up for fuelling from static storage tanks

8.51 The process for refuelling from static storage tanks should be identical to that of refuelling from transit tanks with the exception of setting up system valves to route fuel from the static storage tank to the pumps.

Static storage tank draining

8.52 In order to carry out static storage tank internal inspection, the tank should be empty. It is not always possible to co-ordinate so that stock is run down in time for a scheduled inspection visit and there is always a quantity of dead-stock fuel to drain even when the tank has broken suction. In order to ensure fuel movements from the static storage tanks are controlled so as to maintain fuel traceability and to prevent potential fuel contamination, a list of scenarios are noted below for guidance.

8.53 Some basic principles apply:

- Static storage tanks contain a composite of multiple batches of fuel. Although the fuel pumped into these tanks is of known batch, RD and quality, as there are no facilities to measure RD once fuel is transferred nor to create composite batch numbers, any fuel held in a static storage tank **cannot** be returned onshore for re-use.
- Transit tanks are used to transport traceable fuel of a known RD of which residues are checked on return to the point of filling, therefore, any fuel added to these residues will mean that all fuel in that tank **cannot** be returned onshore for re-use.
- Fuel transferred between tanks using the refuelling system will ensure that contaminants cannot be introduced during the transfer process.
- Any fuel removed from a tank sample line should be disposed of unless it is removed into a sample jar or closed circuit sampler and quality control checks are carried out and found to be acceptable. In this case, the sample can be returned to the sample recovery tank (if fitted) and reintroduced to a static storage tank once maintenance has been completed. All fuel removed from a sample line by other means (e.g. a sump drain pump) should be scrapped.

8.54 Emptying a static storage tank to 'break suction' point:

- 1) Depending on system set up, it may be possible where there is more than one static storage tank to transfer fuel from the tank to be

inspected into another storage tank by orientating the valves to draw from one tank and pump through the transfer vessel into the other tank.

- 2) If fuel cannot be transferred from one storage tank to another and it is possible to locate a transportable tank on the helideck or within reach of the fuel delivery hose, fuel can be pumped to a transportable tank using a crossover connection to connect the delivery system to the tank fill connection as if refuelling an aircraft. The tank should be earth bonded prior to pumping fuel into it. This fuel can then be sampled and transferred back to a static storage tank once maintenance has been completed, however, fuel residues after breaking suction **cannot** be returned onshore for re-use. Residues can either be returned onshore for disposal in the tank, or transferred into a drum or hazardous drain however, the tank should be adequately labelled as containing scrap fuel and manifested as such. Additionally, the tank supplier should be informed that the tank has contained mixed RD fuel and should be cleaned and conditioned once returned onshore.
- 3) If fuel cannot be handled as described above in order to control its quality for re-use, then all fuel in the static storage tank should be decanted to waste. This can be accomplished using the fuel delivery system to pump into a waste fuel tank, drums or hazardous drains until the tank breaks suction. Alternatively, a tank could be drained by fitting a sump drain pump to the sample line before breaking suction as described below.

8.55 Emptying static storage tank dead-stock:

- 1) Dead-stock can be sampled and if satisfactory, decanted into the sample recovery tank (if fitted) and reintroduced to a static storage tank once maintenance has been completed, however, this is a long and laborious process and sample recovery tanks will often not have sufficient capacity to contain all dead-stock.

- 2) A sump drain pump (e.g. a 1” air driven diaphragm pump) can be connected to the static storage sample line end connection and run to suck all fuel out until the tank is empty. This fuel can be pumped to a waste fuel tank, drums or hazardous drains.

Long term storage of aviation fuel

- 8.56 The long term storage of aviation fuel offshore should be discouraged. Should fuel stocks remain unused offshore for an extended period (i.e. six months after the filling date) then, prior to use, samples should be drawn from the tank and sent onshore for laboratory testing to ensure fuel quality. An alternative course of action is to return the transit tank(s) to an onshore fuel depot for further action.

Aircraft refuelling

- 8.57 Refuelling during thunderstorms and significant lightning activity poses significant risks and should therefore be avoided.
- 8.58 Always ensure before starting any refuel that the fuel in the static storage tank or transit tank is properly settled. Refer to paragraph 1.66.1 for correct settling times.
- 8.59 Before the commencement of any helicopter refuel, the HLO should be notified. Unless for specific safety reasons (see 10 below), passengers should normally be disembarked from the helicopter and should be clear of the helideck before refuelling commences. The helideck fire team should be in attendance at all times during any refuelling operation. The following procedure should then apply:
- 1) When the aircraft captain is ready and it has been ascertained how much fuel is required and that the grade of fuel is correct for the particular aircraft, take a fuel sample from the overwing nozzle or from the pressure refuelling coupling sample point and carry out a water detection and fuel quality check in the presence of a flight crew

member (e.g. non-handling pilot) who should witness and acknowledge that the fuel sample colour and water test is acceptable and the fuel is clear from sediments. Morning samples are generally accepted, but a fresh sample may be requested by the pilot. If a flight crew member does not witness the water detection and fuel quality checks in progress, the water detection capsule and sample jar contents should be shown to a flight crew member (e.g. non-handling pilot) after the checks have been carried out.

NOTE: Only if there is no pressure refuelling coupling sample point should a sample be drawn from the fuel filter monitor sample point.

- 2) Run out the earth bonding/EPU lead and attach it to the approved aircraft bonding point. Next, run out the delivery hose on the helideck to the aircraft refuelling point.
- 3) If pressure refuelling, first connect the secondary bonding lead to the approved aircraft bonding point to bond the refuelling nozzle to the aircraft, then connect the pressure coupling to the aircraft and remain adjacent to the fuelling point.
- 4) If gravity refuelling, first connect the secondary bonding lead to bond the refuelling nozzle to the aircraft, then open the tank filler and insert the nozzle and prepare to operate the fuel lever when signalled to do so by the person in charge of refuelling. Ensure fire cover is provided next to the filler point in the form of a dry powder extinguisher.
- 5) The nominated person in charge of the refuelling (e.g. a Helideck Assistant - HDA) should operate the system pump switches and open any necessary valves to start the flow of fuel only when given clearance by the pilot via the HLO; using correct hand signals. The HLO should remain in a position whereby he has full view of both the helicopter refuelling point, pilot (handling) and person operating the fuel station (e.g. HDA). Ideally refuelling teams should be wearing listening headsets so that HLO can communicate instantly with both them and the pilot in the event of an emergency.

- 6) If any abnormalities are observed during the refuelling the “off” switch should immediately be operated. When refuelling is complete or when the pilot signals that tanks are full, the pump should be shut down and the nozzle handle released.
- 7) Remove the refuelling nozzle or disconnect the pressure coupling as appropriate and replace the aircraft filler and nozzle caps. Finally disconnect the secondary bonding lead. A further fuel sample should now be taken as in 1 above and a fuel water and quality check should again be carried out. The process should be witnessed by a flight crew member or the capsule and fuel sample shown to a flight crew member on completion of the tests. See also paragraph 8.18 for sample retention requirements.
- 8) Remove the delivery hose from the helideck and carry out a final check that the aircraft filler cap is secure, then disconnect the main bonding lead from the aircraft and check that all equipment is clear from the proximity of the aircraft. The hose should be rewound onto its reel.
- 9) Enter the fuel quantity onto the daily refuelling sheet and obtain the pilot’s signature for the fuel received.

10) **IMPORTANT SAFETY CONSIDERATIONS**

If for clear flight and helideck operational safety reasons the aircraft captain, in consultation with the HLO, has decided that the refuelling should be carried out with engines and/or rotors running and/or with passengers embarked, the following additional precautions should be undertaken:

NOTE: Refuelling (engines and/or rotors running or stopped) should never be executed while the passengers are embarking or disembarking. The passengers are either on board in accordance with the precautions listed below, or they are kept at a safe distance.

- a) Constant communications should be maintained between the flight crew (pilot handling), HLO and the refuelling crew.

- b) The HLO should remain in a position whereby he has full view of both the helicopter refuelling point, pilot (handling) and the person operating the fuelling installation. Ideally refuel teams should be wearing listening headsets so that HLO can communicate instantly with both them and the pilot in the event of an emergency.
- c) The passengers should be briefed by the pilot and HLO on what actions to take if an incident occurs during refuelling.
- d) The emergency exits opposite the refuelling point should be unobstructed and ready for use (and remain open, weather permitting). Doors on the refuelling side of the helicopter should remain closed.

NOTE: Unless the Rotorcraft Flight Manual (RFM) gives other safety instructions.

- e) Passengers' seatbelts should be undone.
- f) At least one competent HDA should be positioned ready to supervise disembarkation in the event of an emergency.
- g) Provision should be made for safe and rapid evacuation as directed by competent helideck team personnel (HDAs). The area beneath the emergency exits should be kept clear.

NOTE: If the presence of fuel vapour is detected inside the helicopter, or any other hazard arises during refuelling, fuelling should be stopped immediately.

Quality control documentation

8.60 Recording of aviation refuelling system/component manufacture, routine maintenance and rectification, testing, fuel transfer history and aircraft refuelling, etc. should be completed on official company documentation. This documentation is normally provided by the helicopter operators and/or specialist fuel suppliers and system maintainers. As a minimum, the documentation used should comprise:

- Fuel Release Certificate;

- record of transit tank receipt;
- daily and weekly serviceability report;
- daily storage checks;
- differential pressure record;
- hose inspection and nozzle filters test record;
- storage tank checks before and after replenishment;
- fuel system maintenance record;
- tank inspection and cleaning record; and
- fuelling daily log sheet.

8.61 All helifuel related QA documentation should be checked for completeness annually, during an independent inspection or audit. This check should also include helideck team access to CAP 437 Chapters 7 and 8 (latest edition).

Chapter 9

Helicopter landing areas on vessels

Vessels supporting offshore mineral workings and specific standards for landing areas on merchant vessels

- 9.1 Helidecks on vessels used in support of the offshore oil and gas industry should be designed to comply with the requirements of the preceding chapters of this publication.
- 9.2 The ICS has published a 'Guide to Helicopter/Ship Operations', updated in 2008, which comprehensively describes physical criteria and procedures on ships having shipboard heliport landing or winching area arrangements. Other than to address the basic design criteria and marking and lighting schemes related to shipboard heliport landing area arrangements, it is not intended to reproduce detail from the ICS document here in CAP 437. However, it is recommended that the 2008 4th edition of the ICS 'Guide' should be referenced in addition to this chapter and, where necessary, in conjunction with Chapter 10 which includes information relating to shipboard heliport winching area arrangements.
- 9.3 Helicopter landing areas on vessels which comply with the criteria and which have been satisfactorily assessed will be included in the HLL. This list will specify the D-value of the helicopter landing area; include pitch and roll, SHR and helideck inclination category information with helicopter operator derived landing limits; list any areas of non-compliance against CAP 437; and detail any specific limitations applied to the landing area. Vessels having ships'-side or amidships purpose-built or non-purpose-built landing areas may be subject to specific limitations.

- 9.4 Helicopter landing areas on vessels should always have an approved D-value equal to or greater than the 'D' dimension of the helicopter intending to land on it.
- 9.5 Helicopter landing areas which cannot be positioned so as to provide a full 210° obstacle-free sector surface for landing and take-off will be assessed against specific criteria described in this chapter and appropriate limitations will be imposed.
- 9.6 It should be noted that helicopter operations to small vessels with reduced visual cues, such as bow decks or a deck mounted above the bridge superstructure with the landing direction facing forwards (bow deck) or abeam (high deck), in cases where deck landings are permitted at night, will have stricter landing limits imposed with respect to the vessel's movement in pitch and roll, SHR and helideck inclination.

Amidships helicopter landing areas – Purpose-built or non-purpose-built ship's centreline

- 9.7 The following special requirements apply to vessels which can only accommodate a helicopter landing area in an obstructed environment amidships. The centre of the landing area will usually be co-located on the centreline of the vessel, but may be offset from the ship's centreline either to the port or starboard side up to the extent that the edge of the landing area is coincidental with the ship's side.

Size and obstacle environment

- 9.8 The reference D-value (overall dimension of helicopter) given at Table 1 (Chapter 3) also applies to vessels' landing areas referred to in this Chapter. It should also be noted that amidships landing areas are only considered suitable for single main rotor helicopters.
- 9.9 Forward and aft of the minimum 1D landing area should be two symmetrically located 150° LOS with apexes on the circumference of the 'D' reference circle. Within the area enclosing these two sectors, and to

provide 'funnel of approach protection' over the whole of the D-circle, there should be no obstructions above the level of the landing area except those referred to in Chapter 3, paragraph 3.32 which are permitted up to a maximum height of 25 cm above the landing area level. For new build shipboard heliports completed on or after 10 November 2018 and for refurbishments, the height of essential items around the helideck should not exceed 15 cm for any shipboard heliport where the D-value is greater than 16.01m., For any shipboard heliport where the D-value is 16.00 m or less the height of essential items around the helideck should not exceed 5 cm above the landing area level.

- 9.10 On the surface of the landing area itself, objects whose function requires them to be located there, such as deck-mounted lighting systems (see Chapter 4, paragraph 4.22 and Appendix C) and landing area nets (see Chapter 3, paragraph 3.42), should not exceed a height of 2.5 cm.
- 9.11 To provide protection from obstructions adjacent to the landing area, an obstacle protection surface should extend both forward and aft of the landing area. This surface should extend at a gradient of 1:5 out to a distance of D as shown in Figure 1.
- 9.12 Where the requirements for the LOS cannot be fully met but the landing area size is acceptable, it may be possible to apply specific operational limitations or restrictions which will enable helicopters up to a maximum D-value of the landing area to operate to the deck.
- 9.13 The structural requirements referred to in Chapter 3 should be applied whether providing a purpose-built amidships shipboard heliport above a ship's deck or providing a non-purpose-built landing area arrangement utilising part of the ship's structure, e.g. a large hatch cover.

Figure 1: A purpose-built or non-purpose-built midship centreline landing area¹

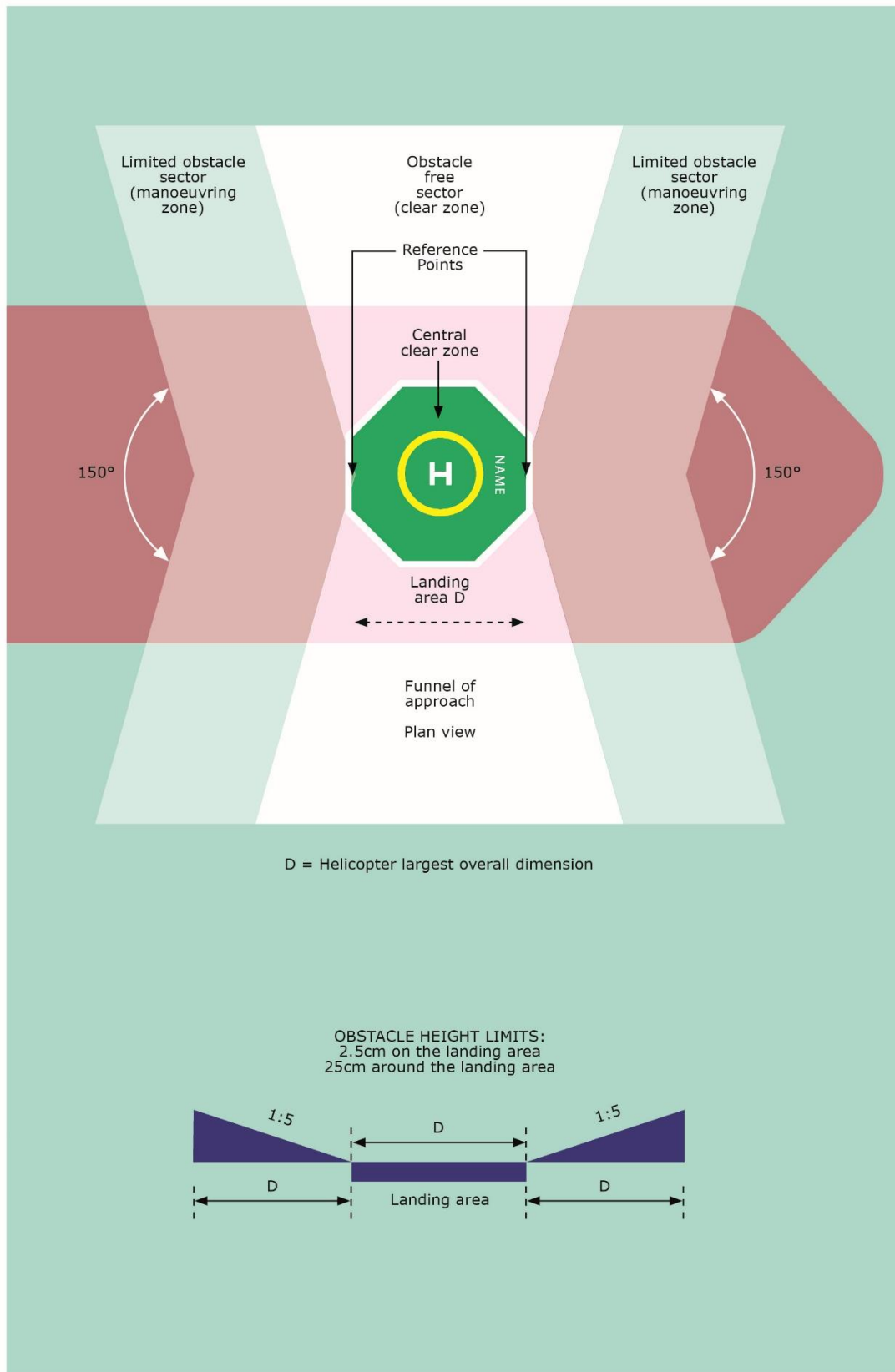

NOTE: Where the D-value is 16.00 m or less the obstacle height limitation around the landing area is restricted to 5 cm (see paragraph 9.9).

Helicopter landing area marking and lighting

9.14 The basic marking and lighting requirements referred to at Chapter 4 and Appendix C will also apply to helicopter landing areas on ships ensuring that for amidships helicopter landing areas the TD/PM Circle should always be positioned in the centre of the landing area and both the forward and aft 'origins' denoting the LOS should be marked with a black chevron (see Chapter 4, Figure 2). In addition, where there is an operational requirement, vessel owners should consider providing the helideck name marking and maximum allowable mass 't' marking both forward and aft of the painted helideck identification 'H' marking and TD/PM Circle.

¹ Figure courtesy of International Chamber of Shipping, Helicopter Ship Guide (2008).

Figure 2: Markings for a purpose-built or non-purpose-built midship centreline landing area²

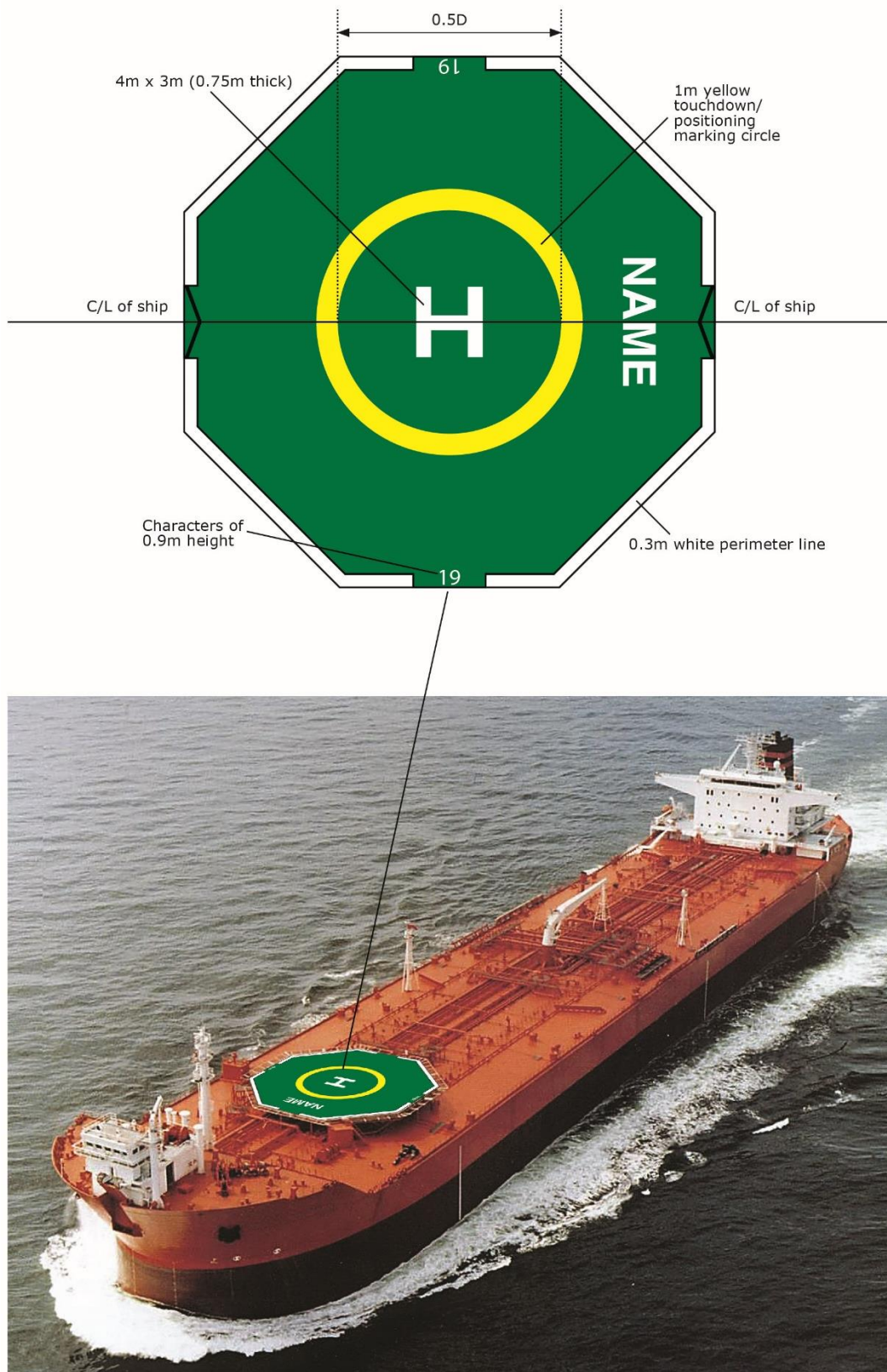

² Original figure courtesy of International Chamber of Shipping, Helicopter Ship Guide (2008).

Ship's side non-purpose-built landing area

- 9.15 A non-purpose-built landing area located on a ship's side should consist of a clear zone and a manoeuvring zone as shown in Figure 3. The clear zone should be capable of containing a circle with a minimum diameter of $1 \times D$. No objects should be located within the clear zone except aids whose presence is essential for the safe operation of the helicopter, and then only up to a maximum height of 2.5 cm. Such objects should only be present if they do not represent a hazard to helicopters. Where there are immovable fixed objects located in the clear zone, such as a Butterworth lid, these should be marked conspicuously and annotated on the ship's operating area diagram (a system of annotation is described in detail in Appendix F to the ICS Helicopter Ship Guide). In addition, a manoeuvring zone should be established, where possible, on the main deck of the ship. The manoeuvring zone, intended to provide the helicopter with an additional degree of protection to account for rotor overhang beyond the clear zone, should extend beyond the clear zone by a minimum of $0.25D$. The manoeuvring zone should only contain obstacles whose presence is essential for the safe operation of the helicopter, and up to a maximum height of 25 cm. Where the D-circle accommodated is 16.00 m or less, obstacles contained in the manoeuvring zone should not exceed a height of 5 cm.

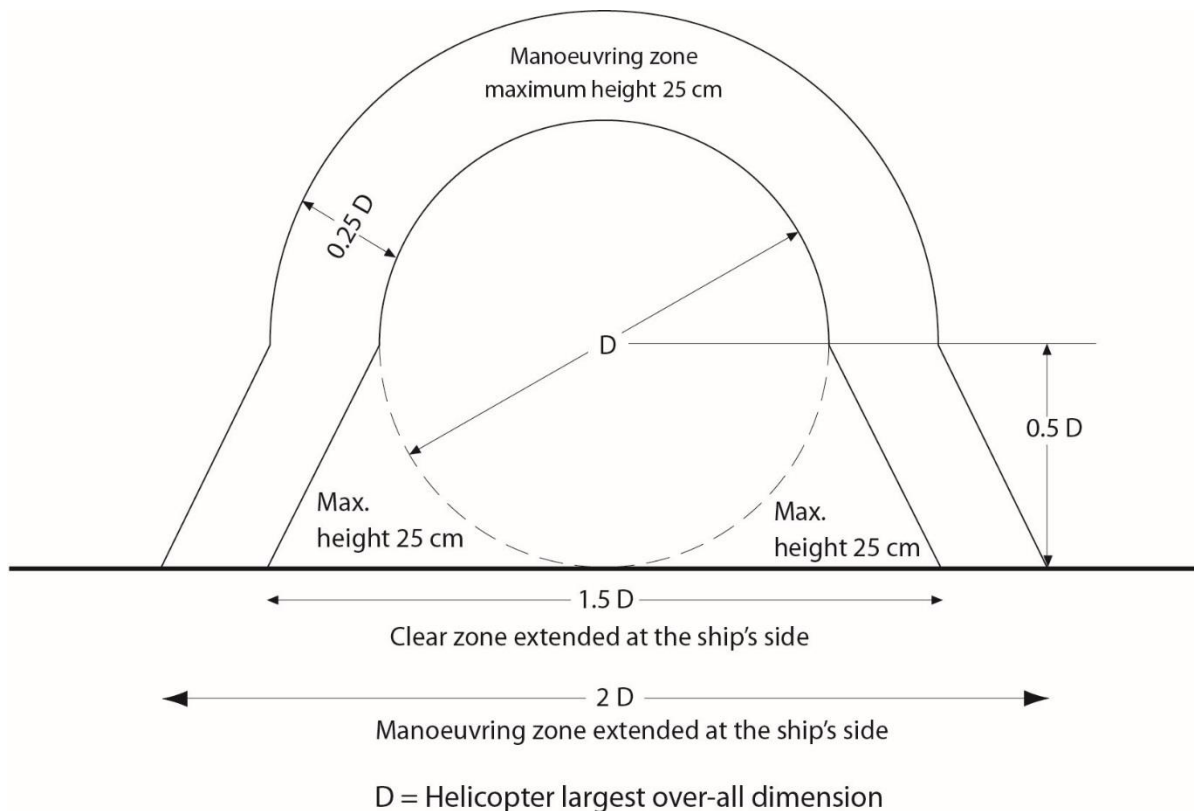
Figure 3: Ship's side - Non-purpose-built landing area (16.0 m or greater)

9.16 Where the operating area is coincident with the ship's side, and in order to improve operational safety, the clear zone should extend to a distance of $1.5D$ at the ship's side while the manoeuvring zone should extend to a distance of $2D$ measured at the ship's side. Within this area, the only obstacles present should be those essential for the safe operation of the helicopter, with a maximum height of 25 cm (or 5 cm where the D-circle accommodated has a diameter of 16.00 m or less). Where there are immovable fixed objects such as tank cleaning lines they should be marked conspicuously and annotated on the ship's operating area diagram (see Appendix F in the ICS Helicopter Ship Guide).

9.17 Any railings located on the ship's side should be removed or stowed horizontally along the entire length of the manoeuvring zone at the ship's side (i.e. over a distance of at least $2D$). All aerials, awnings, stanchions and derricks and cranes within the vicinity of the manoeuvring zone should be either lowered or securely stowed. All dominant obstacles within, or adjacent to, the manoeuvring zone should be conspicuously

marked and, for night operations, lit (see paragraph 9.21 and Chapter 4, paragraphs 4.30 to 4.34).

Ship's side non-purpose-built landing area markings

- 9.18 A TD/PM Circle, denoting the touchdown point for the helicopter, should be located centrally within the clear zone. The diameter of the clear zone should be $1 \times D$ (D being the extent of the available operating area), while the inner diameter of the TD/PM should be $0.5D$. The TD/PM Circle should be at least 0.5 m in width and painted yellow. The area enclosed by the TD/PM Circle should be painted in a contrasting colour, preferably dark green. A white 'H' should be painted in the centre of the circle, with the cross bar of the 'H' running parallel to the ship's side. The 'H' marking should be 4 m high x 3 m wide, the width of the marking itself being 0.75 m.
- 9.19 The boundary of the clear zone, capable of enclosing a circle with a minimum diameter of $1 \times D$ and extending to a total distance of $1.5D$ at the ship's side, should be painted with a continuous 0.3 m wide yellow line. The actual D -value, expressed in metres rounded to the nearest whole number (with 0.5 m rounded down), should also be marked in three locations around the perimeter of the clear zone in a contrasting colour, preferably white. The height of the numbers so marked should be 0.9 m.
- 9.20 The boundary of the manoeuvring zone, located beyond the clear zone and extending to a total distance of $2D$ at the ship's side, should be marked with a 0.3 m wide broken yellow line with a mark: space ratio of approximately 4:1. Where practical, the name of the ship should be painted in a contrasting colour (preferably white) on the inboard side of the manoeuvring zone in (minimum) 1.2 m high characters (see Figure 4).

Figure 4: Ship's side non-purpose-built landing area markings³

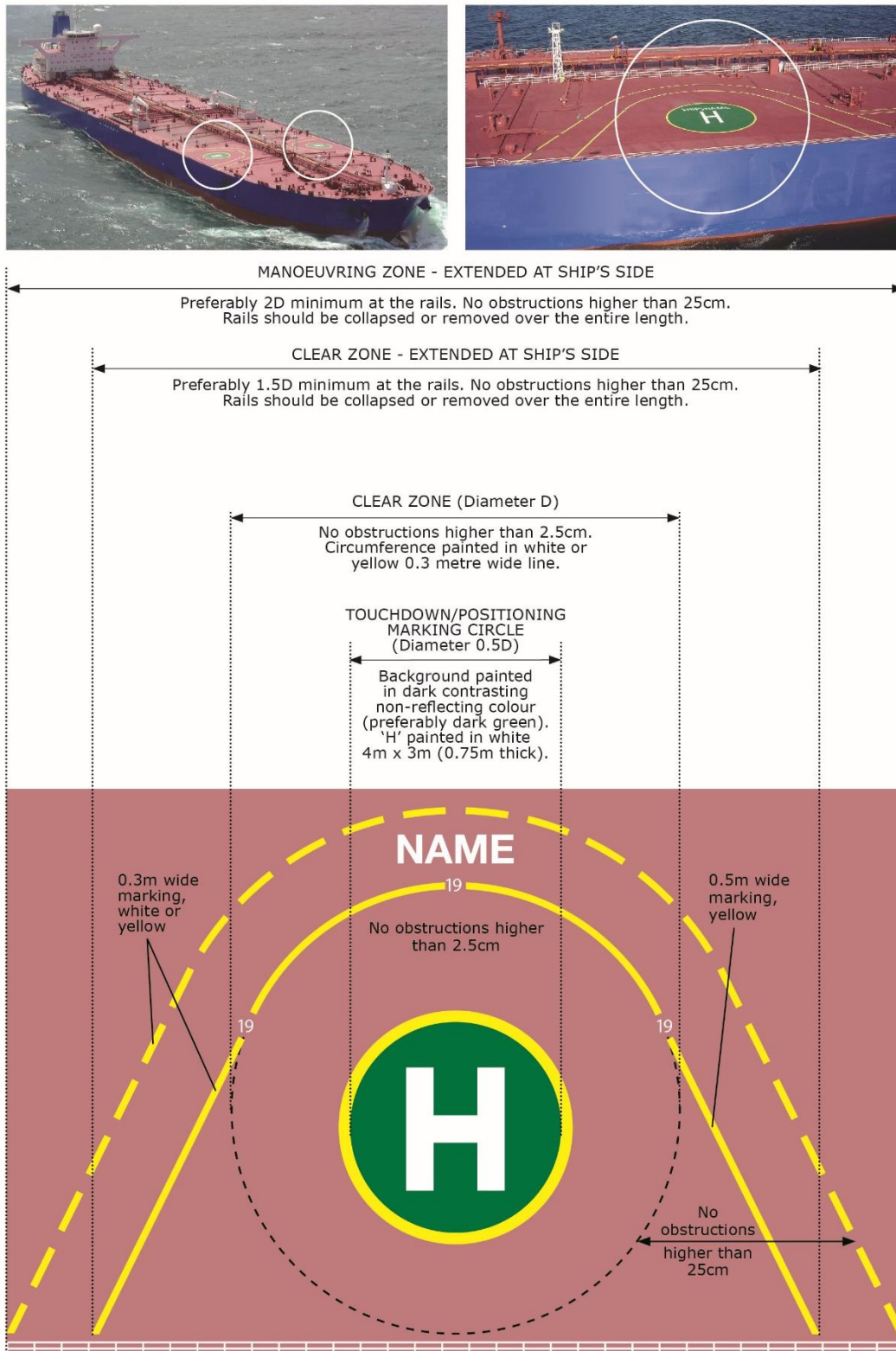

Notes: The diameter in metres of the clear zone 'D' to be marked in white figures of 0.9m at each of the points shown, so as to be easily visible to the helicopter pilot. NB: The diameter (in metres) of the clear zone must be equal to or greater than the overall length of a visiting helicopter with rotors running.

Night operations

9.21 Details of landing area lighting for purpose-built landing areas are given at Chapter 4 and Appendix C. In addition, Figure 5 shows an example of the overall lighting scheme for night helicopter operations (example shows a non-purpose-built ship's side arrangement).

Figure 5: Representative landing area lighting scheme for a non-purpose-built ship's side arrangement⁴

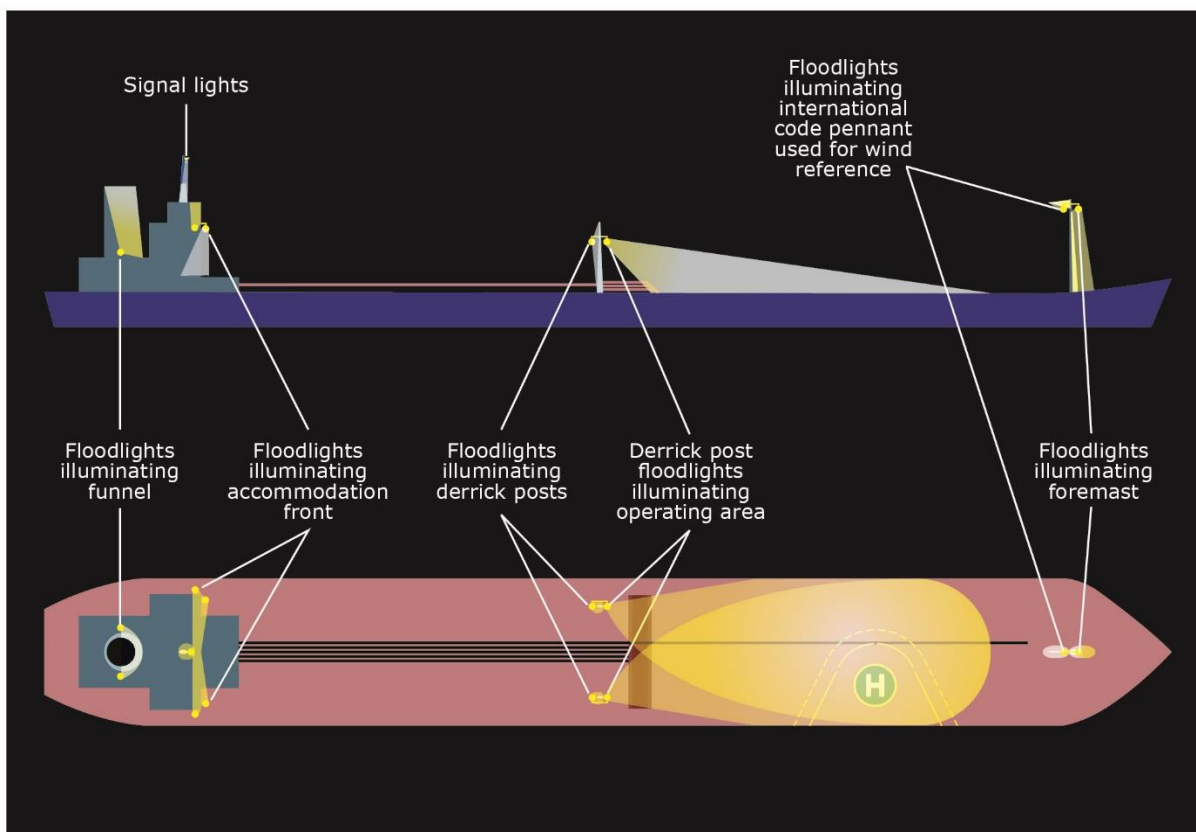

Poop deck operations

9.22 Poop deck operations are addressed fully in the ICS Guide.

³ Original figure courtesy of International Chamber of Shipping, Helicopter Ship Guide (2008).

⁴ Figure courtesy of International Chamber of Shipping, Helicopter Ship Guide (2008).

Chapter 10

Helicopter winching areas on vessels and on wind turbine platforms

Winching areas on vessels

- 10.1 Where practicable, the helicopter should always land rather than hoist, because safety is enhanced when the time spent hovering is reduced. In both cases the Vessel's Master should be fully aware of, and in agreement with, the helicopter pilot's intentions.
- 10.2 The ICS has published a 'Guide to Helicopter/Ship Operations', updated in 2008, which comprehensively describes physical criteria and procedures applicable for a shipboard winching area operation. It is not intended to reproduce the procedures from the ICS document in detail in this eighth edition of CAP 437 and therefore the ICS Guide may need to be referenced in addition to Chapter 10, paragraph 10.1.

Design and obstacle restriction

- 10.3 A winching area should be located over an area to which the helicopter can safely hover whilst hoisting to or from the vessel. Its location should allow the pilot an unimpeded view of the whole of the clear zone whilst facilitating an unobstructed view of the vessel. The winching area should be located so as to minimise aerodynamic and wave motion effects. The area should preferably be clear of accommodation spaces (see also paragraph 10.13) and provide adequate deck area adjacent to the manoeuvring zone to allow for safe access to the winching area from different directions. In selecting a winching area the desirability for keeping the hoisting height to a minimum should also be borne in mind.
- 10.4 A winching area should provide a manoeuvring zone with a minimum diameter of 2D (twice the overall dimension of the largest helicopter permitted to use the area). Within the manoeuvring zone a clear zone

should be centred. This clear zone should be at least 5 m in diameter and should be a solid surface capable of accommodating personnel and/or stores during hoisting operations. It is accepted that a portion of the manoeuvring zone, outside the clear area, may be located beyond the ship's side but should nonetheless comply with obstruction requirements shown in Figure 1. In the inner portion of the manoeuvring zone no obstructions should be higher than 3 m. In the outer portion of the manoeuvring zone no obstructions should be higher than 6 m.

Visual aids

- 10.5 Winching area markings should be located so that their centres coincide with the centre of the clear zone (see Figure 1).
- 10.6 The 5 m minimum diameter clear zone should be painted in a conspicuous colour, preferably yellow, using non-slip paint.
- 10.7 A winching area outer manoeuvring zone marking should consist of a broken circle with a minimum line width of 30 cm and a mark: space ratio of approximately 4:1. The marking should be painted in a conspicuous colour, preferably yellow. The extent of the inner manoeuvring zone may be indicated by painting a thin white line, typically 10 cm thickness.
- 10.8 Within the manoeuvring zone, in a location adjacent to the clear area, 'WINCH ONLY' should be easily visible to the pilot, painted in not less than 2 m characters, in a conspicuous colour.
- 10.9 Where hoisting operations to vessels are required at night, winching area floodlighting should be provided to illuminate the clear zone and manoeuvring zone areas. Floodlights should be arranged and adequately shielded so as to avoid glare to pilots operating in the hover.
- 10.10 The spectral distribution of winching area floodlights should be such that the surface and obstacle markings can be clearly identified. The floodlighting arrangement should ensure that shadows are kept to a minimum.

Figure 1: Winching area arrangement on a vessel⁵

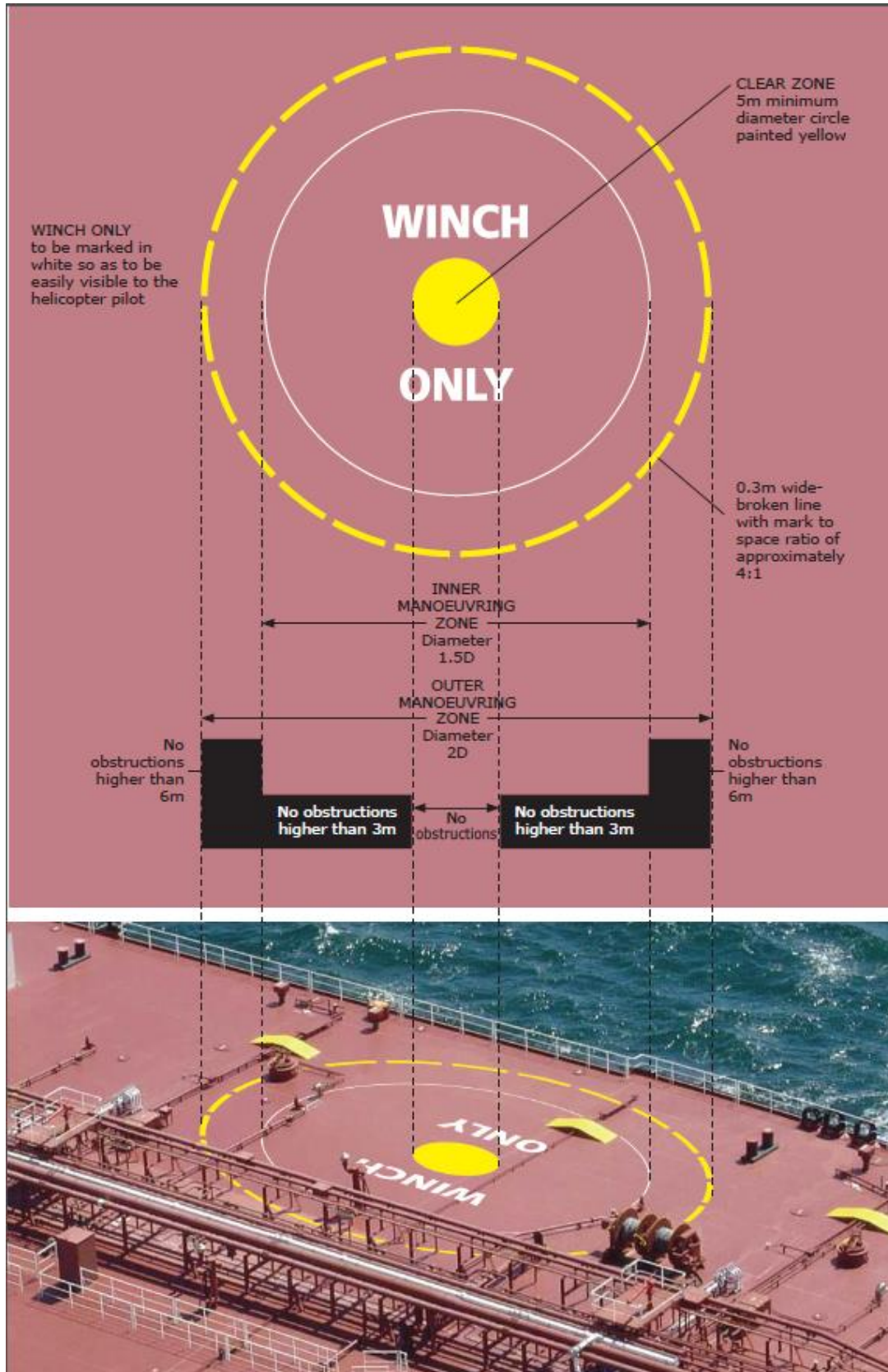

Obstructions

- 10.11 To reduce the risk of a hoist hook or cable becoming fouled, all guard rails, awnings, stanchions, antennae and other obstructions within the vicinity of the manoeuvring zone should, as far as possible, be either removed, lowered or securely stowed.
- 10.12 All dominant obstacles within, or adjacent to, the manoeuvring zone should be conspicuously marked and, for night operations, be adequately illuminated (see paragraphs 10.9 and 10.10. Also see Chapter 4, paragraphs 4.30 to 4.34).

Hoisting above accommodation spaces

- 10.13 Some vessels may only be able to provide winching areas which are situated above accommodation spaces. Due to the constraints of operating above such an area only twin-engined helicopters should be used for such operations and the following procedures adhered to:
- Personnel should be cleared from all spaces immediately below the helicopter operating area and from those spaces where the only means of escape is through the area immediately below the operating area.
 - Safe means of access to and escape from the operating area should be provided by at least two independent routes.
 - All doors, ports, skylights etc. in the vicinity of the aircraft operating area should be closed. This also applies to deck levels below the operating area.
 - Fire and rescue personnel should be deployed in a ready state but sheltered from the helicopter operating area.

Helicopter winching areas on wind turbine platforms

NOTE 1: [CAP 764](#) provides CAA policy and guidelines on wind turbines.

⁵ Figure courtesy of International Chamber of Shipping, Helicopter Ship Guide (2008).

- NOTE 2:** Helicopter hoist operations to wind turbine platforms should be conducted by day in Visual Meteorological Conditions (VMC) only.
- NOTE 3:** The platform design criteria in the following paragraphs have been developed to promote a 'safe and friendly' environment for helicopter hoist operations. It should be recognised that any departure from 'best practice' topside arrangements / platform designs laid out in paragraphs 10.14 to 10.26, including deviations from specified dimensions, has potential to compromise the 'safe and friendly' environment secured for helicopter hoist operations. Therefore any proposed conceptual arrangements should be subjected to appropriate testing including wind tunnel testing and/or CFD studies to establish the wind environment at and above the operating area. Studies undertaken should assess any impact on safe operations that may be caused by an increase in the incidence of turbulence and/or of rotor downwash effects as a result of proposed modified topside arrangements / platform design.

Platform design

- 10.14 The winching area platform (clear area) should be square or rectangular and capable of containing a circle having a minimum diameter of 4.0 m.
- 10.15 In addition to the winching area platform, provision needs to be made for a safety zone to accommodate Helicopter Hoist Operations Passengers (HHOP) at a safe distance away from the winching area during helicopter hoist operations. The minimum safe distance is deemed to be not less than 1.5 m from the inboard edge of the winching (clear) area.
- 10.16 The safety zone should be connected by an access route to the winching area platform located inboard of the winching area platform. The safety zone and associated access route should have the same surface characteristics as the winching area platform (see paragraphs 10.18, 10.19 and 10.20) except that the overall size may be reduced, such that the dimensions of the safety zone and access route are not less than 2.5 m (length) x 0.9 m (width).

- NOTE:** The dimensions of the safety zone may need to be increased according to the maximum number of HHOP that need to be accommodated safely away from the winching (clear) area during helicopter hoist operations.
- 10.17 To differentiate the safety zone and the associated access route from the winching area, it is recommended that the safety zone and access route be painted in contrasting colours to indicate to HHOP where it is safe to congregate during helicopter hoist operations (see paragraph 10.27 and Figure 2).
- 10.18 The platform should be constructed so that it generates as little turbulence as possible. The overall platform design should take account of the need for downdraft from the main rotor to disperse away from the platform. The incidence regarding the discharge of static electricity from the helicopter should be addressed by ensuring that the platform is capable of grounding the hoist wire and aircraft.
- 10.19 The platform deck should be capable of supporting a mass that is approximately five times the weight of an average HHOP.
- 10.20 The surface of the platform, including the safety zone and associated access route, should display suitable friction characteristics to ensure the safe movement of HHOP in all conditions. The minimum friction coefficient, which should be verified prior to installation, is 0.5.
- 10.21 The winching area platform and associated access route and safety zone should be completely enclosed by a 1.5 m high railing system to ensure the safety and security of HHOP at all times. The design of the safety rails should ensure that a free flow of air through the structure is not prevented or disrupted whilst also guaranteeing that no possibility exists for the hoist hook to get entangled in the railing or in any other part of the platform structure. It is permitted for the 1.5m high railing system to be located along the edge, within the specified clear area, of the winching area platform, the associated access route and safety zone.

- 10.22 The surface of the platform should be essentially flat for helicopter hoist operations. However, the floor may slope down towards the outboard edge of the platform to prevent the pooling of water on the platform. It is recommended that a slope not exceeding 2% (1:50) be provided.
- 10.23 The outboard edge of the winching area platform should be located at a minimum horizontal distance from the plane of rotation of the turbine blades that is not less than 1 x the Rotor Diameter (RD) of the largest helicopter intending to conduct hoist operations to the platform. For single main rotor types, the RD is assumed to represent the largest overall width dimension of the helicopter, so that for the widest helicopter authorised to operate to the platform, when located with the centre of the disc directly above the outboard edge of the platform (as depicted in Figure 3), a minimum rotor-tip-to-obstacle clearance of $\frac{1}{2}$ RD (i.e. one rotor radius) is assured. To make allowance for circumstances that may require a helicopter in the hover to move laterally from the edge of the platform in the direction of the turbine blades, a reduction in the minimum rotor-tip-to-obstacle clearance below $\frac{1}{2}$ RD may be permitted. However, in no circumstances should the clearance between the tip-path plane of the main rotor and the plane of rotation of the turbine blades be reduced below 4 m for any helicopter intending to conduct hoist operations to the platform.
- 10.24 During helicopter hoist operations, it is essential that the nacelle should not turn in azimuth and that the turbine blades should also be prevented from rotating by the application of the braking system. Experience in other sectors indicates that it is normal practice for the nacelle to be motored 90 degrees out of wind so that the upwind blade is horizontal and points into the prevailing wind. This is considered to be the preferred orientation for helicopter hoist operations; however, the actual orientation of the blades may vary to suit specific operational requirements.

Obstacle restriction

- 10.25 Within a horizontal distance of 1.5 m measured from the winching (clear) area, no obstacles are permitted to extend above the top of the 1.5 m railing.
- 10.26 Beyond 1.5 m, and out to a distance corresponding to the plane of rotation of the turbine rotor blades, obstacles are permitted up to a height not exceeding 3 m above the surface of the winching area. It is required that only fixed obstacles essential to the safety of the operation are present, e.g. anemometer masts, communications antennae, helihoist status light etc.

Visual aids

- 10.27 The surface of the winching area (a minimum 4 m square 'clear area') should be painted yellow. For the safety zone, green is recommended and a contrasting grey for the associated access route (see Figure 2).
- 10.28 The railings around the entire winching area, safety zone and associated access route should be painted in a conspicuous colour, preferably red.
- 10.29 The wind turbine structure should be clearly identifiable from the air using a simple designator (typically a two-digit or three-digit number with block identification), painted in 1.5 m (minimum) characters in a contrasting colour, preferably black. The turbine designator should be painted on the nacelle top cover ideally utilising an area adjacent to the turbine rotor blades.
- 10.30 A procedure should be put in place to indicate to the helicopter operator that the turbine blades and nacelle are safely secured in position prior to helicopter hoist operations commencing. Experience in other sectors has demonstrated that this is best achieved by the provision of a helihoist status light located on the nacelle of the WTG within the pilot's field of view, which is capable of being operated remotely and from the platform itself or from within the nacelle. In consultation with the industry CAA has developed a system specification utilising a green light capable of

displaying in both steady and flashing signal mode. A steady green light is displayed to indicate to the pilot that the turbine blades and nacelle are secure and it is safe to operate. A flashing green light is displayed to indicate that the turbine is in a state of preparation to accept hoist operations or, when displayed during hoist operations, that parameters are moving out of limits. When the light is extinguished this indicates to the operator that it is not safe to conduct helicopter hoist operations. The full specification for a heli-hoist status light is reproduced at Appendix J.

- 10.31 Requirements for lighting of wind turbine generators in United Kingdom territorial waters, aimed at 'warning off' aircraft transiting the generic area, are addressed in Article 223 of the ANO 2016. See also Directorate of Airspace Policy – Policy Statement for The Lighting of Wind Turbine Generators in United Kingdom Territorial Waters.
- 10.32 Obstruction lighting in the vicinity of the winching area that has a potential to cause glare or dazzle to the pilot or to a helicopter hoist operations crew member should be switched off prior to, and during, helicopter hoist operations.

Figure 2: Winching area, access route and safety zone

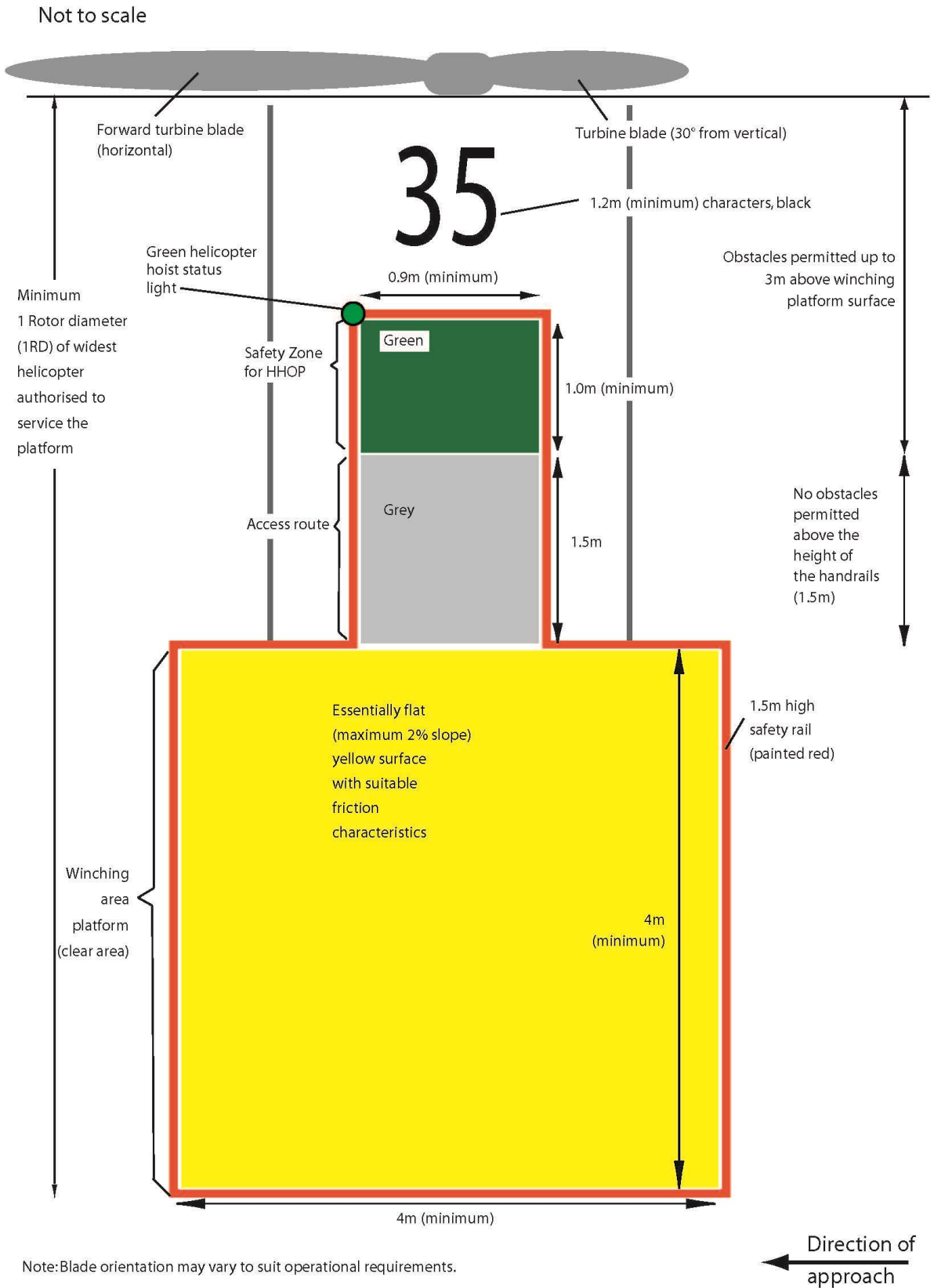
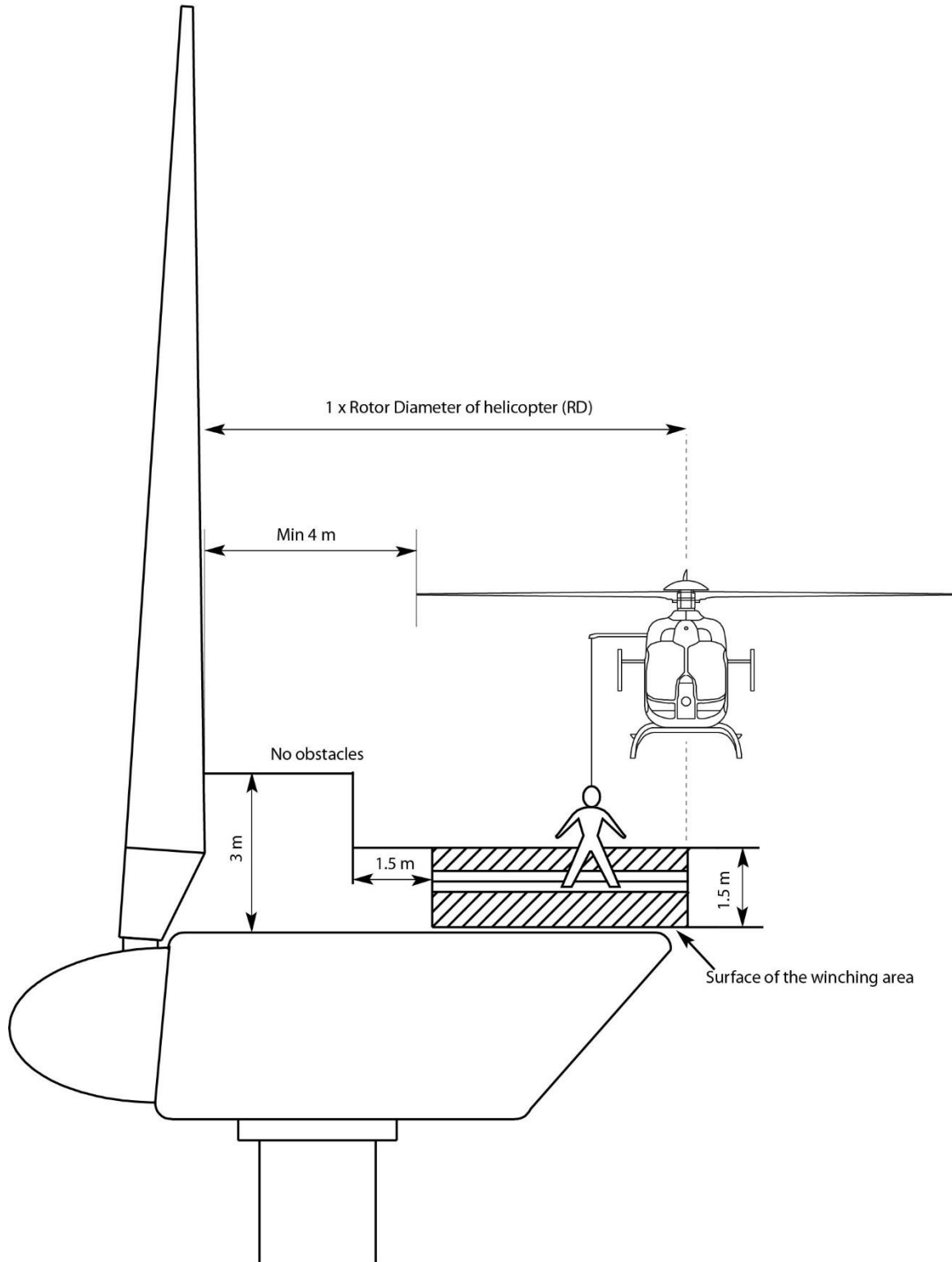

Figure 3: General arrangement drawing showing surfaces and sectors

Not to scale
 (Safety zone and associated access route not shown)



Further operational conditions

- 10.33 For UK operations it is understood to be normal practice for the hoist arrangement to be located on the right hand side of the helicopter with the pilot positioned just on the inboard side of the outboard winching (clear area) platform railings (see Figure 3). In this configuration the pilot's perspective of the platform and turbine blade arrangement should be unimpeded and it is not considered usually necessary to provide any additional visual cues to assist in the maintenance of a safe lateral distance between the helicopter main rotor and the nearest dominant obstacle.
- 10.34 Where cross-cockpit helicopter hoist operations are envisaged an aiming point system may need to be established to assist the pilot in determining the position of the helicopter in relation to the winching area platform and to obstacles. This may be achieved by the provision of a sight point marker system or similar aids. Further guidance may be obtained from Flight Operations Inspectorate (Helicopters) Section.
- 10.35 Offshore Renewables Aviation Guidance (ORAG) on Good Practices for Offshore Renewable Energy Developments was published by RenewableUK in June 2016 - see Appendix B. It is recommended that helicopter hoist operators consult this additional reference source.

Appendix A

Use of offshore locations

AMC1 SPA.HOFO.115

General

- A.1 The operations manual relating to the specific usage of offshore helicopter landing areas (Part C for CAT operators) should contain, or make reference to, a directory of helidecks (Helideck Directory (HD)) intended to be used by the operator. The directory should provide details of helideck limitations and a pictorial representation of each offshore location and its helicopter landing area recording all necessary information of a permanent nature using a standardised template. The HD entries should show, and be amended as necessary, the most recent status of each helideck concerning non-compliance with applicable national standards (i.e. UK CAA CAP 437), limitations, warnings, cautions or other comments of operational importance. An example of a typical template is shown in figure 1 of GM1 SPA.HOFO.115.
- A.2 In order to ensure that the safety of flights is not compromised, the operator should obtain relevant information and details for compilation of the HD, and the pictorial representation from the owner/operator of the offshore helicopter landing area.
- A.3 If more than one name of the offshore location exists, the common name painted on the surface of the landing area should be listed, but other names should also be included in the HD (e.g. radio call sign if different). After renaming an offshore location, the old name should also be included in the HD for the following 6 months.
- A.4 Any limitations associated with an offshore location should be included in the HD. With complex installation arrangements including combinations of installations/vessels (e.g. Combined Operations), a separate listing in the

HD, accompanied by diagrams/pictures where necessary, may be required.

A.5 Each offshore helicopter landing area should be inspected and assessed based on limitations, warnings, instructions and restrictions to determine its acceptability with respect to the following as a minimum:

- 1) The physical characteristics of the landing area including size and load bearing capability and the appropriate 'D' and 't' values.

NOTE: 'D' is the overall length of the helicopter from the most forward position of main rotor tip to the most rearward position of tail rotor tip plane path, or rearmost extension of the fuselage in the case of fenestron or Notar tails. 't' is the maximum allowable mass in tonnes.

- 2) The preservation of obstacle-protected surfaces (an essential safeguard for all flights). These surfaces are:
 - a) the minimum 210° obstacle-free surface (OFS) above helideck level;
 - b) the 150° limited obstacle surface (LOS) above helideck level; and
 - c) the minimum 180° falling '5:1' gradient with respect to significant obstacles below helideck level.

If these sectors/surfaces are infringed, even on a temporary basis, and/or if an adjacent installation or vessel infringes the obstacle protected surfaces related to the landing area, an assessment should be made to determine whether it is necessary to impose operating limitations and/or restrictions to mitigate any non-compliance with the criteria.

- 3) Marking and lighting:
 - a) for operations at night, adequate illumination of the perimeter of the landing area, utilising perimeter lighting meeting national requirements (i.e UK CAA CAP 437);
 - b) for operations at night, adequate illumination of the location of the touchdown marking by use of a lit touchdown/positioning

- marking and lit heliport identification marking meeting national requirements (i.e. UK CAA CAP 437);
- c) status lights (for night and day operations, indicating the status of the helicopter landing area e.g. a red flashing light indicates 'landing area unsafe: do not land') meeting national requirements (i.e. UK CAA CAP 437);
 - d) dominant obstacle paint schemes and lighting;
 - e) condition of helideck markings; and
 - f) adequacy of general installation and structure lighting.

Any limitations with respect to non-compliant lighting arrangements may require the HD to be annotated 'daylight only operations'.

4) Deck surface:

- a) assessment of surface friction;
- b) adequacy and condition of helideck net (where provided);
- c) fit for purpose drainage system;
- d) deck edge safety netting or shelving;
- e) a system of tie-down points adequate for the range of helicopters in use; and
- f) procedures to ensure that the surface is kept clean of all contaminants e.g. bird guano, sea spray, snow and ice.

5) Environment:

- a) foreign object damage;
- b) an assessment of physical turbulence generators e.g. structure-induced turbulence due to clad derrick;
- c) bird control measures;
- d) air flow degradation due to gas turbine exhaust emissions (turbulence and thermal effects), flares (thermal effects) or cold gas vents (unburned flammable gas); and
- e) adjacent offshore installations may need to be included in the environmental assessment.

To assess for potential adverse environmental effects described in (b), (d) and (e), an offshore location should be subject to appropriate studies e.g. wind tunnel testing, CFD analysis.

- 6) Rescue and firefighting:
 - a) systems for delivery of firefighting media to the landing area e.g. DIFFS;
 - b) delivery of primary media types, assumed critical area, application rate and duration;
 - c) deliveries of complementary agent(s), media types, capacity and discharge;
 - d) personal protective equipment (PPE); and
 - e) rescue equipment and crash box/cabinet.
- 7) Communications and navigation:
 - a) aeronautical radio(s);
 - b) radio-telephone (R/T) call sign to match offshore location name and side identification which should be simple and unique; and
 - c) radio log.
- 8) Fuelling facilities:
 - a) In accordance with the relevant national guidance and regulations.
- 9) Additional operational and handling equipment:
 - a) windsock;
 - b) meteorological information including wind, pressure, air temperature and dew point temperature recording displaying mean wind (10 minute wind) and gusts;
 - c) Helideck motion recording and reporting system(HMS) where applicable;
 - d) passenger briefing system;
 - e) chocks;
 - f) tie-down strops/ropes;
 - g) weighing scales;
 - h) a suitable power source for starting helicopters (GPU) where applicable; and
 - i) equipment for clearing the landing area of snow and ice and other contaminants.
- 10) Personnel:

- a) Trained helicopter landing area staff (e.g. helicopter landing officer/helicopter deck assistant and fire-fighters, etc.).
- b) Persons required to assess local weather conditions or communicate with helicopter by radio telephony should be appropriately qualified.

A.6 The HD entry for each offshore location should be completed and kept up to date using the template and reflecting the information and detail in (e) above. The template should contain at least the following (GM1 SPA.HOFO.115 is provided as an example):

- 1) Details:
 - a) name of offshore location;
 - b) R/T call sign;
 - c) helicopter landing area identification marking;
 - d) side panel identification marking;
 - e) landing area elevation;
 - f) maximum installation/vessel height;
 - g) helideck size and/or 'D' value;
 - h) type of offshore location;
 - i) fixed permanently manned installation,
 - ii) fixed normally unattended installation,
 - iii) vessel type (e.g. diving support vessel, tanker, etc.),
 - iv) mobile offshore drilling unit: semi-submersible,
 - v) mobile offshore drilling unit: jack-up,
 - vi) floating production storage offloading (FPSO).
 - i) name of owner/operator;
 - j) geographical position, where appropriate;
 - k) communication and navigation (Com/Nav) frequencies and identification;
 - l) general drawing of the offshore location showing the helicopter landing area with annotations showing location of derrick, masts, cranes, flare stack, turbine and gas exhausts, side identification panels, windsock, etc.;

- m) plan view drawing, chart orientation from the general drawing, to show the above. The plan view will also show the 210 degree sector orientation in degrees true;
- n) type of fuelling:
 - i) pressure and gravity,
 - ii) pressure only,
 - iii) gravity only,
 - iv) none.
- o) type and nature of fire-fighting equipment;
- p) availability of ground power unit (GPU);
- q) deck heading;
- r) 't' value and any approved variations;
- s) status light system (yes/no);
- t) revision date of publication; and
- u) one or more diagram/photograph and any other suitable guidance to assist pilots.

A.7 For offshore locations on which there is incomplete information, 'restricted' usage based on the information available may be considered by the operator, subject to risk assessment prior to the first helicopter visit. During subsequent operations, and before any restriction on usage is lifted, information should be gathered and the following should apply:

- 1) Pictorial (static) representation:
 - a) template blanks (GM1 SPA.HOFO.115 is provided as an example) should be available to be filled in during flight preparation on the basis of the information given by the offshore location owner/operator and flight crew observations;
 - b) where possible, suitably annotated photographs may be used until the HD entry and template have been completed;
 - c) until the HD entry and template have been completed, conservative operational restrictions (e.g. performance, routing, etc.) may be applied;

- d) any previous inspection reports should be obtained and reviewed by the operator; and
 - e) an inspection of the offshore helicopter landing area should be carried out to verify the content of the completed HD entry and template. Once found suitable, the landing area may be considered authorised for use by the operator.
- 2) With reference to the above, the HD entry should contain at least the following:
- a) HD revision date and number;
 - b) generic list of helideck motion limitations;
 - c) name of offshore location;
 - d) helideck size and/or 'D' value and 't' value; and
 - e) limitations, warnings, instructions and restrictions.

GM1 SPA.HOFO.115

Figure 1: Example of a helicopter landing area template

Operator		10-1	(Revision date)	
Installation/vessel name		Position	N/S...	E/W...
Deck height	Installation height	Highest obstacle within 5m	Deck heading	Deck ident.
xxx ft	xxx ft			
AIMS/ICAO code	Radio	Radio	Deck category	Side ident.
			1/2/3	
Deck size (m)	T value (000 kg)	Cleared for (above D or T values)	Installation type	Operator
		(Helicopter type xxx)	(Fixed/semi/etc.)	
Fuel	Ground power	Inspection date	Inspected by	Next due
(Press/gravity/no.)	(AC/DC/No.)			

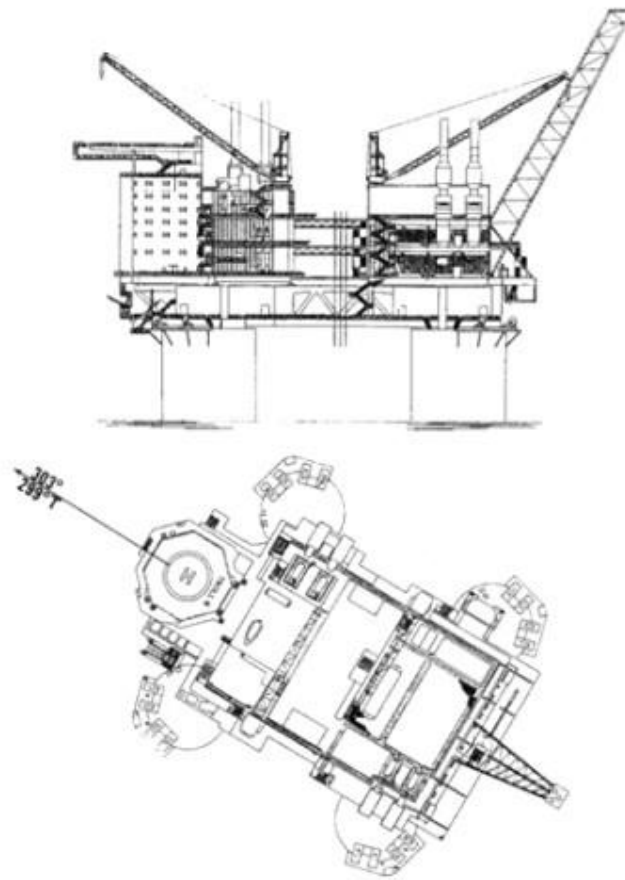

Wind direction	Wind speed	Limitations
(All) (000-050)	All (>30)	(Performance requirements) (Table 2) etc.
5:1 non-compliances		
Additional information		

Appendix B

Bibliography

References

Where a chapter is indicated below it shows where in this CAP the document is primarily referenced.

Health and Safety Executive

Chapter 1

A guide to the Integrity, Workplace Environment and Miscellaneous Aspects of the Offshore Installations and Wells (Design and Construction, etc.) Regulations 1996 HSE Books ISBN 0 7176 1164 7

A guide to the Offshore Installations (Safety Case) Regulations 2005, Third edition 2006 HSE Books, ISBN 0 7176 6184 9

A guide to the Offshore Installations and Pipeline Works (Management and Administration) Regulations 1995 HSE Books ISBN 0 7176 0938 3

Prevention of Fire and Explosion, and Emergency Response on Offshore Installations, Approved Code of Practice and Guidance 1995, HSE Books ISBN 0 7176 0874 3

Chapter 2

Offshore Information Sheet No. 6/2011: Offshore helidecks – testing of helideck foam production systems, August 2011

Chapter 3

Offshore Information Sheet No. 5/2011: Offshore helideck design considerations – environment effects, June 2011

Chapter 4

Operations Notice No. 39: Guidance on identification of offshore installations, June 2008

International Civil Aviation Organization

ICAO Annex 3 Meteorological Service for International Air Navigation

ICAO Annex 14 Volume II Heliports

ICAO Doc 9261 AN/903 Heliport Manual

ICAO Doc 9284 AN/905 Technical Instruction for the Safe Transport of Dangerous Goods by Air

Other publications

Chapter 3

IMO (International Maritime Organization) Mobile Offshore Drilling Units (MODU) Code (2001 consolidated)

ISO (International Organization for Standardization) International Standard ISO 19901-3: Petroleum and Natural Gas Industries – Specific Requirements for Offshore Structures, Part 3: topsides structure (2010-12-10) www.iso.org

Oil & Gas UK Guidelines for the Management of Aviation Operations (Issue 6 - April 2011)

Review of falling 5-in-1 Gradient Criteria of Offshore Platform Operations.

Dr Douglas G Thomson/Prof Roy Bradley – Final Report March 1997. Dr Douglas G Thomson – Addendum to Final Report – July 1999

Chapter 5

Offshore Petroleum Industry Training Organisation (OPITO) Helicopter Landing Officer's Handbook (10th Edition, 2014)

Chapter 6

UKOOA Guidelines for Safety Related Telecommunications Systems On Fixed Offshore Installations

WMO (World Meteorological Organization) Publication No. 306 Manual on Codes
Volume 1.1, Part A Alphanumeric Codes, Code Table 3700 State of the Sea

Chapter 8

Helicopter Refuelling Handbook (7th Edition, 2014)

Chapter 9

Guide to Helicopter/Ship Operations, International Chamber of Shipping, Fourth
Edition, December 2008

Civil Aviation Authority – CAPs, research papers and policy statements

Foreword

CAP 1145 Safety review of offshore public transport helicopter operations in support of the exploitation of oil and gas

CAP 1243 Safety review of offshore public transport helicopter operations in support of the exploitation of oil and Gas.
Progress report

CAP 1295 Consultation: The CAA's intention to assume responsibility for the certification of UK helidecks

CAP 1386 Safety review of offshore public transport helicopter operations in support of the exploitation of oil and gas.
Progress report: 2016

Chapter 1

CAP 1484 CAA/HSE/HSENI Memorandum of Understanding guidance (January 2017)

Chapter 3

CAA Paper 99004 Research on Offshore Helideck Environmental Issues

CAA Paper 2007/02 Visualisation of Offshore Gas Turbine Exhaust Plumes

CAA Paper 2008/02 Study I	Validation of the Helicopter Turbulence Criterion for Operations to Offshore Platforms
CAA Paper 2008/02 Study II	A review of 0.9 m/s Vertical Wind Component Criterion for Helicopters Operating to Offshore Installations
CAA Paper 2008/03	Helideck Design Considerations: Environmental Effects

Chapter 4

CAA Paper 2004/01	Enhancing Offshore Helideck Lighting – NAM K14 Trials
CAA Paper 2005/01	Enhancing Offshore Helideck Lighting – Onshore Trials at Longside airfield
CAA Paper 2006/03	Enhancing Offshore Helideck Lighting – Onshore Trials at Norwich Airport
CAA Paper 2008/01	Specification for an Offshore Helideck Status Light System
CAA Paper 2012/03	Specification for an Offshore Helideck Lighting System

Chapter 6

CAP 413	Radiotelephony Manual
CAP 452	Aeronautical Radio Station Operator's Guide
CAP 670	Air Traffic Services Safety Requirements
CAP 746 (Appendix H)	Meteorological Observations at Aerodromes (Competency of Observers)

Chapter 7

CAP 748	Aircraft Fuelling and Fuel Installation Management
---------	--

Chapter 10

CAP 764	CAA Policy and Guidelines on Wind Turbines
CAP 789	Requirements and Guidance Material for Operators
DAP Policy Statement	The Lighting of Wind Turbine Generators in United Kingdom Territorial Waters

ORAG	Offshore Renewables Aviation Guidance (ORAG) Good Practice Guidelines for Offshore Renewable Energy Developments June 2016
------	--

Sources

British Standards (BS) may be obtained from Her Majesty's Stationery Office, PO Box 276, Nine Elms Lane, London SW8 5DT. Telephone +44 (0) 20 7211 5656 or from any HMSO. Advice on relevant codes (BS, EN and PREN) is available from the CAA at SRG Gatwick.

Civil Aviation Publications (CAPs) and Civil Aviation Authority Papers (CAA Papers) are published on the CAA website at www.caa.co.uk where you may register for e-mail notification of amendments. Please see the inside cover of this CAP for details of availability of paper copy.

HSE Publications from HSE Books, PO Box 1999, Sudbury, Suffolk, CO10 2WA. Telephone +44 (0) 1787 881165 or e-mail hsebooks@prolog.uk.com. Most documents can be downloaded from HSE's website www.hse.gov.uk.

ICAO Publications are available from Airplan Flight Equipment, 1a Ringway Trading Estate, Shadowmoss Road, Manchester M22 5LH. Telephone +44 (0) 161 499 0023. The ICAO website address is www.icao.int.

International Chamber of Shipping Publications from International Chamber of Shipping, 12 Carthusian Street, London, EC1M 6EZ. Telephone +44 (0) 20 7417 2855. E-mail publications@marisec.org.

Oil & Gas UK Publications from Oil & Gas UK, 2nd Floor, 232-242 Vauxhall Bridge Road, London SW1V 1AU. Telephone +44 (0) 20 7802 2400. Website oilandgasuk.co.uk. E-mail info@oilandgasuk.co.uk.

OPITO Publications from OPITO, Inchbraoch house, South Quay, Ferryden, Montrose, Scotland, DD10 9SL. Telephone +44 (0) 1674 662500.

RenewableUK, Greencoat House, Francis Street, London SW1P1DH. Telephone +44 (0) 20 7901 3000. Website: www.RenewableUK.com. E-mail info@RenewableUK.com.

Appendix C

Specification for helideck lighting scheme comprising perimeter lights, lit touchdown/positioning marking and lit heliport identification marking

Overall operational requirement

- C.1 The whole lighting configuration should be designed to be visible over a range of 360° in azimuth. It is possible, however, that on some offshore installations the lighting may be obscured from the pilots' view by topsides structure when viewed from some directions. The design of the helideck lighting is not required to address any such obscuration.
- C.2 The visibility of the lighting configuration should be compatible with the normal range of helicopter vertical approach paths from a range of 2 nautical miles (NM).
- C.3 The purpose of the lighting configuration is to aid the helicopter pilot perform the necessary visual tasks during approach and landing as stated in Table 1.

Table 1: Visual tasks during approach and landing

Phase of approach	Visual task	Visual cues/aids	Desired range (NM)	
			5,000m met. vis.	1,400 m met. vis.
Helideck location and identification	Search within platform structure	Shape of helideck; colour of helideck; luminance of helideck, perimeter lighting.	1.5 (2.8 km)	0.75 (1.4 km)
Final approach	Detect helicopter position in three	Apparent size/shape and change of size/shape of	1.0 (1.8 km)	0.5 (900 m)

	axes, detect rate of change of position.	helideck, orientation and change of orientation of known features/markings/lights.		
Hover and landing	Detect helicopter attitude, position and rate of change of position in three axes (six degrees of freedom).	Known features/markings/lights, Helideck texture.	0.03 (50 m)	0.03 (50 m)

- C.4 The minimum intensities of the lighting configuration should be adequate to ensure that, for a minimum Meteorological Visibility (Met. Vis.) of 1400 m and an illuminance threshold of 10-6.1 lux, each feature of the system is visible and useable at night from ranges in accordance with C.5, C.6 and C.7.
- C.5 The Perimeter Lights are to be visible at night from a minimum range of 0.75 NM.
- C.6 The Touchdown/Positioning Marking (TD/PM) Circle on the helideck is to be visible at night from a range of 0.5 NM.
- C.7 The Heliport Identification Marking ('H') is to be visible at night from a range of 0.25 NM.
- C.8 The minimum ranges at which the TD/PM Circle and 'H' are visible and useable (see paragraphs C.6 and C.7 above), should still be achieved even where a correctly fitted landing net covers the lighting.
- C.9 The design of the Perimeter Lights, TD/PM Circle and 'H' should be such that the luminance of the Perimeter Lights is equal to or greater than that of the TD/PM circle segments, and the luminance of the TD/PM circle segments equal to or greater than that of the 'H'.
- C.10 The design of the TD/PM Circle and 'H' should include a facility to enable their intensity to be increased by up to approximately two times the figures

given in this specification to permit a once-off (tamper proof) adjustment at installation; the maximum figures should not be exceeded. The purpose of this facility is to ensure adequate performance at installations with high levels of background lighting without risking glare at less well-lit installations. The TD/PM Circle and 'H' should be adjusted together using a single control to ensure that the balance of the overall lighting system is maintained in both the 'standard' and 'bright' settings.

Definitions

C.11 The following definitions should apply:

Lighting element

C.12 A lighting element is a light source within a segment or sub-section and may be discrete (e.g. a Light Emitting Diode (LED)) or continuous (e.g. fibre optic cable, electro luminescent panel). An individual lighting element may consist of a single light source or multiple light sources arranged in a group or cluster, and may include a lens/diffuser.

Segment

C.13 A segment is a section of the TD/PM circle lighting. For the purposes of this specification, the dimensions of a segment are the length and width of the smallest possible rectangular area that is defined by the outer edges of the lighting elements, including any lenses/diffusers.

Sub-section

C.14 A sub-section is an individual section of the 'H' lighting. For the purposes of this specification, the dimensions of a sub-section are the length and width of the smallest possible rectangular area that is defined by the outer edges of the lighting elements, including any lenses/diffusers.

The perimeter light requirement

Configuration

C.15 Perimeter lights, spaced at intervals of not more than 3 m, should be fitted around the perimeter of the landing area of the helideck as described in Chapter 4, paragraph 4.19.

Mechanical constraints

C.16 For any helideck where the D-value is greater than 16.00 m the perimeter lights should not exceed a height of 25 cm above the surface of the helideck. Where a helideck has a D-value of 16.00 m or less the perimeter lights should not exceed a height of 5 cm above the surface of the helideck.

Light intensity

C.17 The minimum light intensity profile is given in Table 2 below:

Table 2: Minimum light intensity profile for perimeter lights

Elevation	Azimuth	Intensity (min.)
0° to 10°	-180° to +180°	30 cd
>10° to 20°	-180° to +180°	15 cd
>20° to 90°	-180° to +180°	3 cd

C.18 No perimeter light should have an intensity of greater than 60 cd at any angle of elevation. Note that the design of the perimeter lights should be such that the luminance of the perimeter lights is equal to or greater than that of the TD/PM Circle segments.

Colour

C.19 The colour of the light emitted by the perimeter lights should be green, as defined in ICAO Annex 14 Volume 1 Appendix 1, paragraph 2.1.1(c), whose chromaticity lies within the following boundaries:

- Yellow boundary $x = 0.360 - 0.080y$
- White boundary $x = 0.650y$
- Blue boundary $y = 0.390 - 0.171x$

Serviceability

- C.20 The perimeter lighting is considered serviceable provided that at least 90% of the lights are serviceable, and providing that any unserviceable lights are not adjacent to each other.

The touchdown/positioning marking circle requirement

Configuration

- C.21 The lit TD/PM circle should be superimposed on the yellow painted marking such that it is concentric with the painted circle and contained within it. It should comprise one or more concentric circles of at least 16 discrete lighting segments, of 40 mm minimum width. The segments should be straight or curve in sympathy with the painted circle. A single circle should be positioned such that the radius of the circle formed by the centre line of the lighting segments is within 10 cm of the mean radius of the painted circle. Multiple circles should be symmetrically disposed about the mean radius of the painted circle. The lighting segments should be of such a length as to provide coverage of between 50% and 75% of the circumference and be equidistantly placed with the gaps between them not less than 0.5 m. A single non-standard gap up to 25% larger or smaller than the remainder of the circle is permitted at one location to facilitate cable entry. The mechanical housing should be coloured yellow - see CAP 437 Chapter 4 paragraph 4.18.

Mechanical constraints

- C.22 The height of the lit TD/PM circle fixtures (e.g. segments) and any associated cabling should be as low as possible and should not exceed 25 mm. The overall height of the system, taking account of any mounting arrangements, should be kept to a minimum. So as not to present a trip

hazard, the segments should not present any vertical outside edge greater than 6 mm without chamfering at an angle not exceeding 300 from the horizontal.

- C.23 The overall effect of the lighting segments and cabling on deck friction should be minimised. Wherever practical, the surfaces of the lighting segments should meet the minimum deck friction limit coefficient (μ) of 0.65 (see Chapter 3 paragraph 3.38), e.g. on non-illuminated surfaces.
- C.24 The TD/PM circle lighting components, fitments and cabling should be able to withstand a pressure of at least 1,655 kPa (240 lbs/in²) and ideally 3,250 kPa (471 lbs/in²) without damage.

Intensity

- C.25 The light intensity for each of the lighting segments, when viewed at angles of azimuth over the range + 80° to -80° from the normal to the longitudinal axis of the strip (see Figure 1), should be as defined in Table 3.

Table 3: Light intensity for lighting segments on the TD/PM circle

Elevation	Intensity	
	Min.	Max.
0° to 10°	As a function of segment length as defined in Figure 2	60 cd
>10° to 20°	25% of min intensity >0° to 10°	45 cd
>20° to 90°	5% of min intensity >0° to 10°	15 cd

- C.26 For the remaining angles of azimuth on either side of the longitudinal axis of the segment, the maximum intensity should be as defined in Table 3.
- C.27 The intensity of each lighting segment should be nominally symmetrical about its longitudinal axis. The design of the TD/PM Circle should be such that the luminance of the TD/PM Circle segments is equal to or greater than the sub-sections of the 'H'.

Figure 1: TD/PM segment measurement axis system

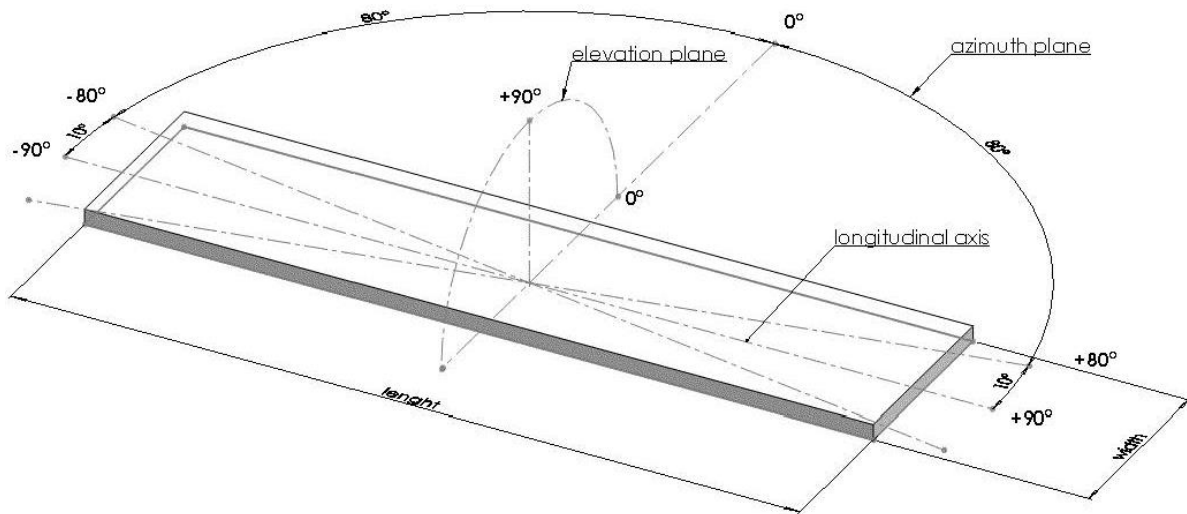
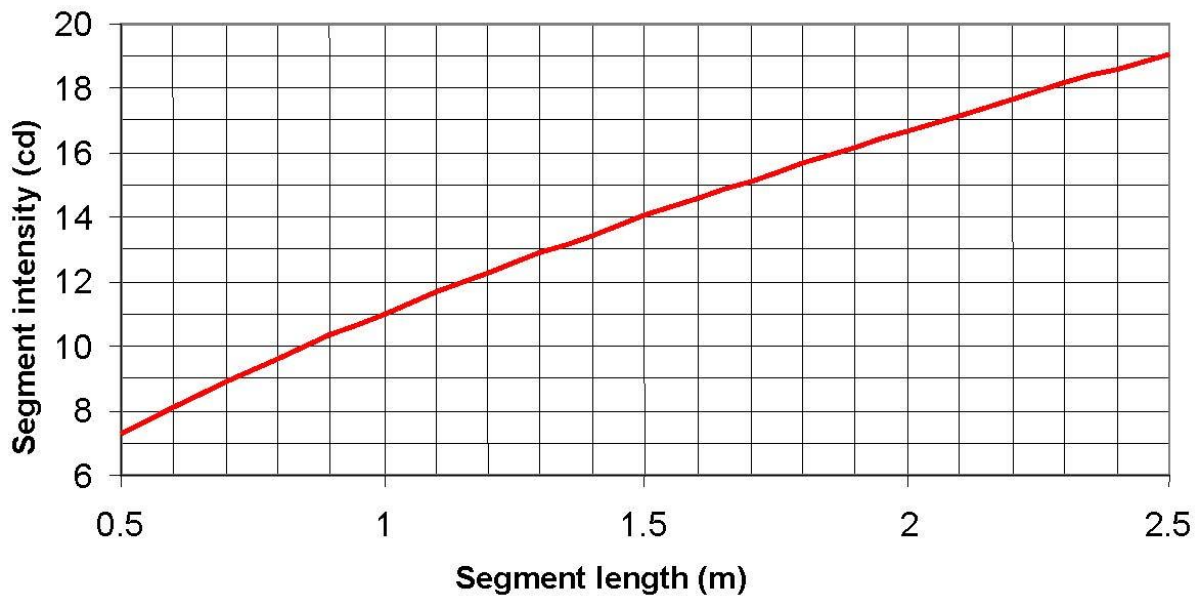

Figure 2: TD/PM segment intensity versus segment length



NOTE: Given the minimum gap size of 0.5 m and the minimum coverage of 50%, the minimum segment length is 0.5 m. The maximum segment length depends on deck size, but is given by selecting the minimum number of segments (16) and the maximum coverage (75%).

C.28 If a segment is made up of a number of individual lighting elements (e.g. LED's) then they should be of the same nominal performance (i.e. within manufacturing tolerances) and be equidistantly spaced throughout the segment to aid textural cueing. Minimum spacing between the illuminated

areas of the lighting elements should be 3 cm and maximum spacing 10 cm.

- C.29 On the assumption that the intensities of the lighting elements will add linearly at longer viewing ranges where intensity is more important, the minimum intensity of each lighting element (i) should be given by the formula:

$$i = I / n$$

where: I = required minimum intensity of segment at the 'look down' (elevation) angle (see Table 3)
n = the number of lighting elements within the segment

- NOTE:** The maximum intensity at each angle of elevation should also be divided by the number of lighting elements within the segment.

- C.30 If the segment comprises a continuous lighting element (e.g. fibre optic cable, electro luminescent panel), then to achieve textural cueing at short range, the element should be masked at 3.0 cm intervals on a 1:1 mark-space ratio.

Colour

- C.31 The colour of the light emitted by the TD/PM circle should be yellow, as defined in ICAO Annex 14 Volume 1 Appendix 1, paragraph 2.1.1(b), whose chromaticity is within the following boundaries:

- Red boundary $y = 0.382$
- White boundary $y = 0.790 - 0.667x$
- Green boundary $y = x - 0.120$

Serviceability

- C.32 The TD/PM Circle: A segment is inoperative if less than 50% of its lighting elements are operating; partially operative if less than 100% but 50% or more of its lighting elements are operating. Up to 10% (or two whichever

is the higher) of the segments may be inoperative or up to 20% (or four whichever is the higher) of the segments may be partially inoperative.

NOTE: Where combinations of failures occur, one inoperative segment is equivalent to two partially operative segments).

The heliport identification marking requirement

Configuration

C.33 The lit Heliport Identification Marking ('H') should be superimposed on the 4 m x 3 m white painted 'H' (limb width 0.75 m). The lit 'H' should be 3.9 to 4.1 m high, 2.9 to 3.1 m wide and have a stroke width of 0.7 to 0.8 m. The centre point of the lit 'H' may be offset from the centre point of the painted 'H' in any direction by up to 10 cm in order to facilitate installation (e.g. avoid a weld line on the helideck surface). The limbs should be lit in outline form as shown in Figure 3.

Figure 3: Configuration and dimensions of heliport identification marking 'H'

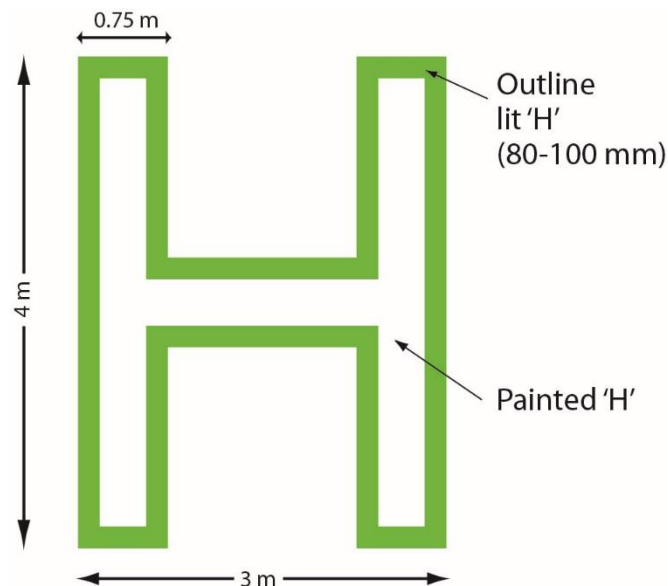

C.34 An outline lit 'H' should comprise sub-sections of between 80 mm and 100 mm wide around the outer edge of the painted 'H' (see Figure 3). There are no restrictions on the length of the sub-sections, but the gaps between

them should not be greater than 10 cm. The mechanical housing should be coloured white – see CAP 437 Chapter 4 paragraph 4.18.

Mechanical constraints

- C.35 The height of the lit 'H' fixtures (e.g. subsections) and any associated cabling should be as low as possible and should not exceed 25 mm. The overall height of the system, taking account of any mounting arrangements, should be kept to a minimum. So as not to present a trip hazard, the lighting strips should not present any vertical outside edge greater than 6 mm without chamfering at an angle not exceeding 30° from the horizontal.
- C.36 The overall effect of the lighting sub-sections and cabling on deck friction should be minimised. Wherever practical, the surfaces of the lighting sub-sections should meet the minimum deck friction limit coefficient (μ) of 0.65 (see Chapter 3 paragraph 3.38), e.g. on non-illuminated surfaces.
- C.37 The 'H' lighting components, fitments and cabling should be able to withstand a pressure of at least 1,655 kPa (240 lbs/in²) and ideally 3,250 kPa (471 lbs/in²) without damage.

Intensity

- C.38 The intensity of the lighting along the 4 m edge of an outline 'H' over all angles of azimuth is given in Table 4 below.

Table 4: Light intensity of the 4 m edge of the 'H'

Elevation	Intensity	
	Min.	Max.
2° to 12°	3.5 cd	60 cd
>12° to 20°	0.5 cd	30 cd
>20° to 90°	0.2 cd	10 cd

- NOTE:** For the purposes of demonstrating compliance with this specification, a sub-section of the lighting forming the 4 m edge of the 'H' may be used. The minimum length of the sub-section should be 0.5 m.
- C.39 The outline of the H should be formed using the same lighting elements throughout.
- C.40 If a sub-section is made up of individual lighting elements (e.g. LED's) then they should be of nominally identical performance (i.e. within manufacturing tolerances) and be equidistantly spaced within the sub-section to aid textural cueing. Minimum spacing between the illuminated areas of the lighting elements should be 3 cm and maximum spacing 10 cm.
- C.41 With reference to C.29, due to the shorter viewing ranges for the 'H' and the low intensities involved, the minimum intensity of each lighting element (i) for all angles of elevation (i.e. 2° to 90°) should be given by the formula:
- $$i = I / n$$
- where: I = required minimum intensity of sub-section at the 'look down' (elevation) angle between 2° and 12° (see Table 4).
 n = the number of lighting elements within the sub-section.
- NOTE:** The maximum intensity at any angle of elevation should be the maximum between 2° and 12° (see Table 4) divided by the number of lighting elements within the sub-section.
- C.42 If the 'H' is constructed from a continuous light element (e.g. fibre optic cables or panels, electroluminescent panels), the luminance (B) of the 4 m edge of the outline 'H' should be given by the formula:
- $$B = I / A$$
- where: I = intensity of the limb (see Table 4)
 A = the projected lit area at the 'look down' (elevation) angle

- C.43 If the sub-section comprises a continuous lighting element (e.g. fibre optic cable, electro luminescent panel), then to achieve textural cueing at short range, the element should be masked at 3.0 cm intervals on a 1:1 mark-space ratio.

Colour

- C.44 The colour of the 'H' should be green, as defined in ICAO Annex 14 Volume 1 Appendix 1, paragraph 2.1.1(c), whose chromaticity is within the following boundaries:
- Yellow boundary $x = 0.360 - 0.080y$
 - White boundary $x = 0.650y$
 - Blue boundary $y = 0.390 - 0.171x$

Serviceability

- C.45 The 'H': A subsection is inoperative if less than 50% of its lighting elements are operating; partially operative if less than 100% but 50% or more of its lighting elements are operating. Up to 10% (or three whichever is the higher) of the subsections may be inoperative or up to 20% (or six whichever is the higher) of the subsections may be partially inoperative.

NOTE: Where combinations of failures occur, one inoperative subsection is equivalent to two partially operative subsections.

General characteristics

- C.46 The general characteristics detailed in the paragraphs below apply to helideck perimeter lighting as well as the TD/PM Circle and 'H' lighting except where otherwise stated.

Requirements

- C.47 The following items are fully defined and form firm requirements.
- C.48 All lighting components should be tested by an independent test house. The photometrical and colour measurements performed in the optical

department of this test house should be accredited according to the version of EN ISO/IEC 17025 current at the time of the testing.

C.49 As regards the attachment of the TD/PM Circle and 'H' to the helideck, the failure mode requiring consideration is detachment of components of the TD/PM Circle and 'H' lighting due to shear loads generated during helicopter landings. The maximum horizontal load may be assumed to be that defined in Chapter 3 paragraph 3.20, 4), i.e. the maximum take-off mass (MTOM) of the largest helicopter for which the helideck is designed multiplied by 0.5, distributed equally between the main undercarriage legs. This requirement applies to components of the circle and H lighting having an installed height greater than 6 mm and a plan view area greater than or equal to 200 cm².

NOTE 1: Example – for a helicopter MTOM of 14,600kg, a horizontal load of 35.8kN should be assumed.

NOTE 2: For components having plan areas significantly larger than 200cm², distribution of shear loads should be considered.

C.50 Provision should be included in the design and installation of the system to allow for the effective drainage of the helideck areas inside the TD/PM Circle and the 'H' lighting (see Chapter 3 paragraph 3.44). The design of the lighting and its installation should be such that, when mounted on a smooth flat plate with a slope of 1:100, a fluid spill of 200 litres inside the H lighting will drain from the circle within 2 minutes. The maximum drainage time applies primarily to aviation fuel, but water may be used for test purposes. The maximum drainage time does not apply to fire fighting agents.

Other considerations

C.51 The considerations detailed in this section are presented to make equipment designers aware of the operating environment and customer expectations during the design of the products/system. They do not

represent formal requirements but are desirable design considerations of a good lighting system.

- C.52 All lighting components and fitments should meet safety regulations relevant to a helideck environment such as explosion proofing (Zone 1 or 2 as appropriate) and flammability and be tested by a notified body in accordance with the ATEX directive or equivalent locally applicable hazardous area certification standards.
- C.53 All lighting components and fitments installed on the surface of the helideck should be resistant to attack by fluids that they will likely or inevitably be exposed to such as fuel, hydraulic fluid, and those used for de-icing, cleaning and fire-fighting. In addition they should be resistant to UV light, rain, sea spray, guano, snow and ice. Components should be immersed in each of the fluids individually for at least one hour and then checked to ensure no degradation of mechanical properties (i.e. surface friction and resistance to contact pressure), any discolouration, or any clouding of lenses/diffusers. Any other substances that may come into contact with the system that may cause damage should be identified in the installation and maintenance documentation.
- C.54 All lighting components and fitments that are mounted on the surface of the helideck should be able to operate within a temperature range appropriate for the local ambient conditions.
- C.55 All cabling should utilise low smoke/toxicity, flame retardant cable. Any through-the-deck cable routing and connections should use sealed glands, type approved for helideck use.
- C.56 All lighting components and fitments should meet IEC International Protection (IP) standard IP66 and IP67, i.e. dust tight and resistant to powerful water jetting and temporary submersion in water. The intent is that the system should be compatible with deck cleaning activities using pressure washers, and local flooding (i.e. puddling) on the surface of the helideck.

Appendix D

Helideck fire fighting provisions for existing NUI assets on the UK continental shelf

Appendix D1

Introduction

On 1st July 2016 CAA agreed a new scheme with the industry aimed at addressing deficiencies in the fire fighting provisions at the 117 normally unattended installations (NUIs) operating on the UKCS listed in Appendix D2. The scheme provides installation duty holders with a degree of flexibility in meeting the minimum requirements for effective fire fighting provisions detailed in Chapter 5, for both the case when fire fighting equipment is attended and when it is unattended, in order to adequately address the reasonably foreseeable event of a post crash fire. The scheme is summarised in the table below which is based on the agreed start date of 1st January 2017.

The basic concept behind the scheme is to allow the option of limiting exposure to the risk of a post crash fire as an alternative to reducing the associated probability or mitigating the consequences. In view of the wide range of potential causes, achieving an adequate reduction in the probability of a post crash fire event is considered to be unrealistic. Mitigation through the provision of fire-fighting equipment as detailed in Chapter 5 is possible but may be uneconomic for some installations.

The Scheme is mandated by a CAA Operational Directive addressing offshore helicopter helideck operations, and comprises the following elements:

1. For any helidecks which do not comply with the requirements for the installation of an automated fire-fighting system, from 1st January 2017 an annual limit of 120 landings will be applied when the helideck is unattended to constrain overall exposure. In addition, operations to such

decks may not take place at night unless a circle and H helideck lighting system compliant with Appendix C is fitted.

2. When helidecks without an automated fire-fighting system are attended by personnel trained in the use of the fire-fighting equipment that is available, operations may continue with that equipment until 31st December 2017.
3. From 1st January 2018, the fire-fighting facilities should meet or exceed the H1 / H2 Rescue and Fire Fighting Service (RFFS) provisions detailed in this appendix.
4. Helidecks without an automated fire-fighting system that do not upgrade to the level stated in 3) above by 31st December 2017 will, in addition to the limit on unattended landings, be subject to an annual limit on the total number of landings of 200 from 1st January 2018), decreasing to 160 from 1st January 2019 and finally decreasing to 120 from 1st January 2020.

The scheme is summarised in the table below which is based on the agreed start date of 1st January 2017. The limits on the number of landings are derived from CAP 789 where 120 landings represents the upper limit for 'standard operations'.

Alternative solutions supported by a safety case acceptable to the CAA will be considered. Safety cases should describe in detail the operation (number of unattended / attended / day / night operations), aircraft types (including certification standards and configuration) and fire-fighting provisions, and explain how the risks are to be minimised and managed..

Equipment installed			Number of unattended (total number) of landings permitted*				
Automatic fire fighting	H1/H2 compliant	Circle and H lighting	From 01 January 2017	From 01 January 2018	From 01 April 2018	From 01 January 2019	From 01 January 2020
✓	-	✓	UL	UL	UL	UL	UL
✓	-	✗	UL	UL	UL Night ban	UL Night ban	UL Night ban
✗	✓	✓	120 (UL)	120 (UL)	120 (UL)	120 (UL)	120 (UL)
✗	✓	✗	120 (UL) Night ban **	120 (UL) Night ban **	120 (UL) Night ban	120 (UL) Night ban	120 (UL) Night ban
✗	✗	✓	120 (UL)	120 (200)	120 (200)	120 (160)	120 (120)
✗	✗	✗	120 (UL) Night ban **	120 (200) Night ban **	120 (200) Night ban	120 (160) Night ban	120 (120) Night ban

* UL = unlimited.

** Night bans prior to 01 April 2018 apply to unattended landings only. Night time is defined as 30 minutes after sunset to 30 minutes prior to sunrise.

The purpose of the remainder of Appendix D1 is to set out the minimum technical requirements for an H1/H2 provision to address the landing case when fire fighting equipment is attended. H1/H2 compliance is indicated in column 2 of the summary table above. A platform duty holder who wishes to ensure an effective fire fighting provision that will also cover landings occurring when fire fighting equipment is unattended will need to install an automatic fire-fighting system. The scheme described in detail in CAA's letter to Oil and Gas UK Ltd dated 01 July 2011, presented in Appendix D2, addresses column 1 of the summary table above.

It is the responsibility of each platform duty holder to determine which scheme is most appropriate for an asset based on the operational requirements and taking account of the restrictions detailed in the summary table above. A key factor in this determination will be the exposure to the risk of a post crash fire in terms of the anticipated annual number of landings on the helideck. It should be noted that the summary table is applicable only to the 117 NUI assets listed in Appendix 2 of the industry letter reproduced at Appendix D2.

Definitions

- Helicopter Category H1: A helicopter with an overall length up to but not including 15m.
- Helicopter Category H2: A helicopter with an overall length from 15m up to, but not including, 24m.

H1/H2 scheme details

H1 RFFS standard

Table 1: Extinguishing agent requirements for H1 standard

Foam meeting performance level B		Complementary agents		
Water (litres)	Discharge rate foam solution (l/min)	Dry chemical powder (kg)	and	CO ₂ (kg)
500	250	23		18

NOTE 1: The discharge rate of complementary agents should be selected for optimum effectiveness of the agent used.

NOTE 2: Dry chemical powder should be of a foam compatible type which is capable of dealing with Class B fire for liquid hydrocarbons.

NOTE 3: Primary and secondary complementary agents should be delivered from one or two extinguishers.

Table 1 is predicated on a helicopter with an overall length up to, but not including, 15.0m, having an assumed average fuselage length of 8.5m and an average fuselage width of 1.5m (to which an additional width factor W1 of 4m is applied). However, most of the H1 types currently operated on the UKCS have fuselage lengths and fuselage widths which significantly exceed the H1 mean values derived from Table 6-4 of the ICAO Heliport Manual (doc. 9261). Therefore it is necessary to recalculate the critical area assumed for the larger AS365N2/N3 types on the basis of a helicopter fuselage length of 11.63m and a fuselage width of 2.03m. See Table 2, H1 RFFS Large below.

H1 RFFS large

Table 2: Extinguishing agent requirements for AS365N2 and AS365N3 operations

Foam meeting performance level B		Complementary agents		
Water (litres)	Discharge rate foam solution (l/min)	Dry chemical powder (kg)	and	CO ₂ (kg)
770	385	23		18

NOTE 1: The discharge rate of complementary agents should be selected for optimum effectiveness of the agent used.

NOTE 2: Dry chemical powder should be of a foam compatible type which is capable of dealing with Class B fire for liquid hydrocarbons.

NOTE 3: Primary and secondary complementary agents should be delivered from one or two extinguishers.

NOTE 4: As an alternative to H1 RFFS large, helidecks operating AS365N2/N3 types may alternatively select the quantities applicable to H2 RFFS Standard in Table 3.

H2 RFFS standard

Table 3: Extinguishing agent requirements for H2 standard

Foam meeting performance level B		Complementary agents		
Water (litres)	Discharge rate foam solution (l/min)	Dry chemical powder (kg)	and	CO ₂ (kg)
1000	500	45		18

NOTE 1: The discharge rate of complementary agents should be selected for optimum effectiveness of the agent used.

NOTE 2: Dry chemical powder should be of a foam compatible type which is capable of dealing with Class B fire for liquid hydrocarbons.

NOTE 3: Primary and secondary complementary agents should be delivered from one or two extinguishers.

Table 3 is predicated on a helicopter with an overall length of 15.0m up to, but not including, 24.0m, having an assumed average fuselage length of 14.5m and an average fuselage width of 2m (to which an additional width factor W1 of 4m is applied). However, a number of NUIs, in the NNS, are operated by types which have a fuselage length and fuselage width that significantly exceeds the H2 mean values derived from Table 6-4 of the ICAO Heliport Manual (doc. 9261). Therefore, in this case it is necessary to recalculate the assumed critical area on the basis of the dimensions of a worst-case S92 helicopter, having a fuselage length of 17.10m and a fuselage width, including sponsons, of 3.90m. See Table H2 RFFS Large below.

H2 RFFS large

Table 4: Extinguishing agent requirements for S92 operations

Foam meeting performance level B		Complementary agents		
Water (litres)	Discharge rate foam solution (l/min)	Dry chemical powder (kg)	and	CO ₂ (kg)
1500	750	45		18

NOTE 1: The discharge rate of complementary agents should be selected for optimum effectiveness of the agent used.

NOTE 2: Dry chemical powder should be of a foam compatible type which is capable of dealing with Class B fire for liquid hydrocarbons.

NOTE 3: Primary and secondary complementary agents should be delivered from one or two extinguishers.

Appendix D2

Letter to industry July 2011

Safety Regulation Group

Flight Operations Inspectorate (Helicopters)

Mr Robert Paterson
Health, Safety and Employment Issues Director
Oil and Gas UK Ltd
3rd Floor
62 The Exchange
Market Street
Aberdeen
AB11 5PJ

01 July 2011

Dear Robert,

Helideck Fire-fighting Provisions For Existing Normally Unattended Installation (NUI) Assets on the United Kingdom Continental Shelf

1. Background to the problem on existing NUI assets on the UKCS

Helidecks in the UK sector of the North Sea are regarded as unlicensed operating sites. Under Article 96 of the Air Navigation Order (ANO), offshore helicopter operators are required to satisfy themselves that each helideck they operate to is 'suitable for the purpose'. Helicopter operators discharge their duty of care through

an inspection programme undertaken on their behalf by the Helideck Certification Agency (HCA), who assesses helidecks and related facilities against standards and best practice in UK Civil Aviation Publication CAP 437. In essence the HCA Certification process provides an assurance to the helicopter operators that they are fulfilling their duty of care under the ANO in only operating to helidecks that are suitable for the purpose.

Chapter 5 of CAP 437 contains detailed prescriptive requirements for Rescue and Fire-Fighting Services (RFFS) that are based on international standards and recommended practices in ICAO Annex 14 Volume II and the Heliport Manual (Doc. 9261). For manned installations and vessels and for new build NUIs, best practice requirements specify the delivery of foam (e.g. AFFF) at a high application rate and for an extended duration dispensed from either a Fixed Monitor System (FMS) or from a Deck Integrated Fire-Fighting System (DIFFS). For a NUI, which is unmanned for at least the first and last flight of the day, an automatically activated DIFFS ideally with a passive fire-retarding surface is preferred since this solution provides for automatic fire suppression and active intervention in the event of a major fire situation occurring during a take-off or landing where all trained fire crews are otherwise located in the helicopter.

Historically, for existing NUI facilities on the United Kingdom Continental Shelf (UKCS), CAP 437 'current best practice' has not been applied for RFFS and, until recently platform operators selected an RFFS on the basis of United Kingdom Offshore Operators Association (UKOOA) 'Guidelines for the Management of Offshore Helideck Operations' (Issue 5 - Feb 2005). The 'UKOOA Guidelines', which have been superseded by Oil and Gas UK 'Guidance for the Management of Aviation Operations (Issue 6, April 2011 - containing no specific reference to NUI RFFS), stipulated only minimal fire-fighting media requirements which were broadly equivalent to scales specified for a low intensity H1 helicopter operation at a temporary onshore heliport (reference source: CAP 789, Annex 3 to Chapter 21). It was not intended that such a minimal provision of primary fire-fighting media should be deemed acceptable for a permanent heliport operation, operating in a remote location in a hostile environment onto minimum size elevated landing areas, routinely using helicopters that are not only larger than the H1 category, but also carry more

passengers and fuel compared to helicopters typically utilizing the CAP 789 low intensity requirements. Using the risk assessment elements promulgated in Section 1 of Appendix 1 to this letter, it is not justifiable to select such a reduced level of fire cover when all these factors are considered together.

It is evident that the current arrangements for RFFS on fixed NUI platforms on the UKCS are inadequate to address all likely, and reasonably foreseeable, fire situations that may be encountered during routine offshore helicopter operations. For this reason, taking account also of concerns raised by the offshore helicopter operators and the HCA, and with the support of the UK Health and Safety Executive, CAA has undertaken to conduct a review of the minimum scales of fire fighting media that would be appropriate for existing NUI assets operating on the UK Continental Shelf (for a full list of assets see Appendix 2). The following sections provide detailed outcomes of the review conducted with reference to other sources of UK best practice (including CAP 168 and CAP 789) and ICAO Annex 14 Volume II and the Heliport Manual (doc. 9261). Offshore duty holders and helicopter operators should be aware that the scales presented in this letter are considered to be minimum requirements for each specific category and, having determined the appropriate scale, agreed between the platform operator and helicopter operator, specific NUIs may still decide to select scales of media that are different from those prescribed, providing they are no lower than the appropriate baseline scale.

2. Determination of an appropriate Rescue and Fire Fighting Service (RFFS)

In the following sections a total of twenty seven separate options are provided for the consideration of primary media within nine tables promulgated on the basis of the following:

- 1) Whether the NUI operation is classed as “Low Intensity”, “Standard Intensity” or “Higher intensity”. (See definitions in Appendix 1, Section 2.)
- 2) Whether the largest helicopter operating to the NUI is classed within “Helicopter Category H1 Large”, “Helicopter Category H2 Medium” or “Helicopter Category H2 Large”. (See definitions in Appendix 1, Section 3.)

- 3) Whether the type of foam being discharged meets “ICAO Performance Level B”, “Performance Level B (Compressed Air Foam System)” or “ICAO Performance Level C”. (See discussion in Appendix 1, Section 4.)

In all cases the complementary media requirements for gaseous media and Dry Powder are identical, being based on CAP 437, Chapter 5, Section 4. Likewise the rescue equipment requirements are the same for every category, being based on CAP 437, Chapter 5, Section 7 (see also Appendix 1, Section 6). The requirements for Personal Protective Equipment (PPE) are specified in Appendix 1, Section 7.

In accordance with Appendix 1, Section 5, there is an inbuilt assumption that whatever method is used for discharging foam to the helideck, the response time objectives of CAP 437, Chapter 5, Section 2.2 are upheld; such that a delay of less than 15 seconds should be the operational objective measured from the time the system is activated to the actual production of foam at the required application rate. Depending on the overriding fire fighting objectives and assumptions (see Appendix 1, Section 5), the scales are presented to ensure the effective discharge of foam will last either for a minimum of 2 minutes or 5 minutes.

3. Determining the appropriate scale for each individual NUI operation

On the assumption the largest helicopter operating to a NUI and the Performance Level of selected foam are fully objectively derived, only the determination of categorisation of intensity, whether ‘low’, ‘standard’ or ‘higher’, has any degree of subjectivity attached. However, for each category of operation space for interpretation is very restricted since the threshold limits on helicopter and passenger movements, whether determined against a monthly or annual limit and the planned occupation of the NUI are pre-supposed in the definition. The scales presented for a low intensity operation, by taking account of the low number of annual movements, accept that the likelihood of a serious accident occurring with a serious fire ensuing are comparatively lower. When deciding whether an operation is classed as ‘standard’ or ‘higher’, there should be full recourse to the elements contained in the helicopter transport risk assessment (see Appendix 1, Section 1) to determine which of the remaining scales a specific NUI operation will fall into and whether in-fact there is a case for providing an RFFS which exceeds the baseline limit. There should

also be a commitment to reviewing the elements of the helicopter transport risk assessment on an annual basis to ensure that the scales of RFFS provided for a NUI continue to be appropriate in accordance with the overall level of risk. Any conclusions arising from the risk assessment, to support a certain 'level' of operation, should be agreed with the helicopter operator, through the HCA.

4. Methods for primary foam delivery to the helideck

For a NUI, regardless of the policy on manning, there will always be occasions when a helicopter is required to approach to land or take-off from the installation when it is unattended. When in an 'unattended' mode this assumes there is nobody on the helideck to operate the foam dispensing equipment in the event of a crash occurring involving a fire situation. Therefore, it is necessary that any system of foam delivery is capable of discharging automatically, without the necessity for manual intervention. CAP 437, Chapter 5 discusses the main options for the effective discharge of foam to an offshore helicopter landing area and presents specifications for a Fixed Monitor System (FMS) in Section 2.3 and for a Deck Integrated Fire Fighting System (DIFFS) in Section 2.9. It is firstly essential for a NUI that where a DIFFS or an FMS are selected to discharge foam to the landing area they are able to be immediately and automatically activated in the event of a fire occurring. Likewise these systems should be able to deliver finished foam to any part of the helideck at or above the minimum application rate for the range of weather conditions prevalent for the UKCS. A DIFFS, consisting of a series of pop-up nozzles by design should more easily achieve the effective and even distribution of foam to all parts of the landing area because the pattern of 'pop-up' sources can be arranged over the whole landing area (note: individual pop-ups should be sited in such a way to allow unimpeded right of entry to all access platforms). However, experience from other offshore sectors in the North Sea operating automatic RFFS on NUIs, has highlighted also the possibility of a ring-main system (RMS) arrangement, where a series of nozzles are located equally-spaced right around the perimeter of the landing area, within prescribed height limits for the 210° sector and 1st segment limited obstacle sector, so that foam is discharged from all directions around the helideck. Any system selected should be automatically initiated but with a manual override function on the NUI and from an adjacent mother platform or from the

beach. An FMS will need to have a built in capability to allow for self-oscillation of monitors.

Whatever method of foam delivery is determined, it is important that the equipment selected is low maintenance such that any checks prescribed by the manufacturer can ideally be contained within routine maintenance cycles for the platform. It should be the objective of platform operators to avoid having to make additional unscheduled visits to the platform simply to service fire-fighting equipment, which could have a detrimental effect on the overall risk profile for the platform. Experience suggests, for example, that selecting pre-mix sealed foam systems, cable of discharging aspirated or non-aspirated foam will usually require less effort to maintain.

5. Which installations need to review their current RFFS provision?

Based on information provided by the HCA in interrogating the Helideck Limitations List (HLL), there are understood to be 116 NUIs operating within the UKCS. These installations are listed, by region, in Appendix 2. This list includes all NUIs regardless of their existing RFFS provision. Thus Appendix 2 may be assumed as the definitive list of installations that need to review their current RFFS provision. The list of 116 NUIs is understood to encompass the assets of approximately 20 offshore duty holders currently serviced by a range of helicopters from three offshore helicopter operators. It is important, before any rectification action is implemented, that the platform operator provides full movement/manning data to the helicopter operator to facilitate discussion and agree a methodology and programme for any upgrade of RFFS. Prior to implementation, it will be necessary for the HCA to endorse any action plan. HCA will wish to ensure that any rectification work, including the physical location of foam dispensing equipment, does not compromise CAP 437 obstruction criteria or invalidate any conditions of the current landing area certificate for the installation.

6. Scales of primary and secondary media for existing asset NUIs**Large H1 RFFS Standard Intensity**

Extinguishing Agent Requirements

Foam Meeting Performance Level B			Foam Meeting Performance Level C			Complementary Agent	
Total foam solution (Litres)	Minimum discharge rate of foam (L/Min)	Minimum duration (Min)	Total foam solution (Litres)	Minimum discharge rate of foam (L/Min)	Minimum duration (Min)	Dry chemical powder (kg)	Gaseous agent (kg)
900 (650)	450 (325)	2 (2)	600	300	2	45	18

Notes:

- 1) Complementary agents should be capable of discharge at an effective rate delivered from one or two extinguishers.
- 2) Halon extinguishing agents are no longer prescribed for new installations. Gaseous agents, including CO₂ have replaced them. Gaseous extinguishers should be provided with a suitable applicator for use on engine fires.
- 3) Dry Chemical Powder should be a foam compatible type capable of dealing with Class B fire (or liquid hydrocarbons).
- 4) Pre-mix foam systems should be fully automatic and be capable of activating instantaneously in the event of an impact of a helicopter on the helideck where fire results. The automatic system should dispense aspirated or non-aspirated foam in a jet or spray pattern.
- 5) Where a Compressed Air Foam System (CAFS) meeting Performance Level B is selected in lieu of standard foam, the capacity and application rate may be accordingly reduced. The minimum requirements for CAFS are shown within the bracketed values in the above table.

Large H1 RFFS Low Intensity

Extinguishing Agent Requirements

Foam Meeting Performance Level B			Foam Meeting Performance Level C			Complementary Agent	
Total foam solution (Litres)	Minimum discharge rate of foam (L/Min)	Minimum duration (Min)	Total foam solution (Litres)	Minimum discharge rate of foam (L/Min)	Minimum duration (Min)	Dry chemical powder (kg)	Gaseous agent (kg)
150	75	2	120	60	2	45	18

Notes:

- 1) Complementary agents should be capable of discharge at an effective rate delivered from one or two extinguishers.
- 2) Halon extinguishing agents are no longer prescribed for new installations. Gaseous agents, including CO₂ have replaced them. Gaseous extinguishers should be provided with a suitable applicator for use on engine fires.
- 3) Dry Chemical Powder should be a foam compatible type capable of dealing with Class B fire (or liquid hydrocarbons).
- 4) Premix-foam units may be aspirated or non-aspirated but should be capable of delivering agent to the seat of the fire.
- 5) Where a Compressed Air Foam System (CAFS) meeting Performance Level B selected in lieu of standard foam, the capacity and application rate may be accordingly reduced. The minimum requirements for CAFS in this case are assumed to be equivalent to amounts specified for Performance Level C foams.

Large H1 RFFS Higher Intensity

Extinguishing Agent Requirements

Foam Meeting Performance Level B			Foam Meeting Performance Level C			Complementary Agent	
Total foam solution (Litres)	Minimum discharge rate of foam (L/Min)	Minimum duration (Min)	Total foam solution (Litres)	Minimum discharge rate of foam (L/Min)	Minimum duration (Min)	Dry chemical powder (kg)	Gaseous agent (kg)
2250 (1625)	450 (325)	5 (5)	1500	300	5	45	18

Notes:

- 1) Complementary agents should be capable of discharge at an effective rate delivered from one or two extinguishers.
- 2) Halon extinguishing agents are no longer prescribed for new installations. Gaseous agents, including CO₂ have replaced them. Gaseous extinguishers should be provided with a suitable applicator for use on engine fires.
- 3) Dry Chemical Powder should be a foam compatible type, capable of dealing with Class B fire (or liquid hydrocarbons).
- 4) Pre-mix foam systems should be fully automatic and be capable of activating instantaneously in the event of an impact of a helicopter on the helideck where fire results. The automatic system should dispense aspirated or non-aspirated foam in a jet or spray pattern.
- 5) The primary media levels specified for a higher intensity operation which is staffed for more than 50% of public transport helicopter movements, assumes a fire attack lasting approximately 5 minutes. It is acceptable, within the overall strategy, to employ at least one additional hand-controlled foam branch pipe for the delivery of aspirated foam, to any part on the landing area or its appendages, with a minimum discharge rate of 225 L/Min.
- 6) Where a Compressed Air Foam System (CAFS) meeting Performance Level B is selected in lieu of standard foam, the capacity and application rate may be accordingly reduced. The minimum requirements for CAFS are shown within the bracketed values in the above table.

Medium H2 RFFS Standard Intensity

Extinguishing Agent Requirements

Foam Meeting Performance Level B			Foam Meeting Performance Level C			Complementary Agent	
Total foam solution (Litres)	Minimum discharge rate of foam (L/Min)	Minimum duration (Min)	Total foam solution (Litres)	Minimum discharge rate of foam (L/Min)	Minimum duration (Min)	Dry chemical powder (kg)	Gaseous agent (kg)
1200 (850)	600 (425)	2 (2)	800	400	2	45	18

Notes:

- 1) Complementary agents should be capable of discharge at an effective rate delivered from one or two extinguishers.
- 2) Halon extinguishing agents are no longer prescribed for new installations. Gaseous agents, including CO₂ have replaced them. Gaseous extinguishers should be provided with a suitable applicator for use on engine fires.
- 3) Dry Chemical Powder should be a foam compatible type, capable of dealing with Class B fire (or liquid hydrocarbons).
- 4) Pre-mix foam systems should be fully automatic and be capable of activating instantaneously in the event of an impact of a helicopter on the helideck where fire results. The automatic system should dispense aspirated or non-aspirated foam in a jet or spray pattern.
- 5) Where a Compressed Air Foam System (CAFS) meeting Performance Level B is selected in lieu of standard foam, the capacity and application rate may be accordingly reduced. The minimum requirements for CAFS are shown within the bracketed values in the above table.

Medium H2 RFFS Low Intensity

Extinguishing Agent Requirements

Foam Meeting Performance Level B			Foam Meeting Performance Level C			Complementary Agent	
Total foam solution (Litres)	Minimum discharge rate of foam (L/Min)	Minimum duration (Min)	Total foam solution (Litres)	Minimum discharge rate of foam (L/Min)	Minimum duration (Min)	Dry chemical powder (kg)	Gaseous agent (kg)
310	155	2	220	110	2	45	18

Notes:

- 1) Complementary agents should be capable of discharge at an effective rate delivered from one or two extinguishers.
- 2) Halon extinguishing agents are no longer prescribed for new installations. Gaseous agents, including CO₂ have replaced them. Gaseous extinguishers should be provided with a suitable applicator for use on engine fires.
- 3) Dry Chemical Powder should be a foam compatible type, capable of dealing with Class B fire (or liquid hydrocarbons).
- 4) Premix-foam units may be aspirated or non-aspirated but should be capable of delivering agent to the seat of the fire.
- 5) Where a Compressed Air Foam System (CAFS) meeting Performance Level B is selected in lieu of standard foam, the capacity and application rate may be accordingly reduced. The minimum requirements for CAFS in this case are assumed to be equivalent to amounts specified for Performance Level C foams.

Medium H2 RFFS Higher Intensity

Extinguishing Agent Requirements

Foam Meeting Performance Level B			Foam Meeting Performance Level C			Complementary Agent	
Total foam solution (Litres)	Minimum discharge rate of foam (L/Min)	Minimum duration (Min)	Total foam solution (Litres)	Minimum discharge rate of foam (L/Min)	Minimum duration (Min)	Dry chemical powder (kg)	Gaseous agent (kg)
3000 (2125)	600 (425)	5 (5)	2000	400	5	45	18

Notes:

- 1) Complementary agents should be capable of discharge at an effective rate delivered from one or two extinguishers.
- 2) Halon extinguishing agents are no longer prescribed for new installations. Gaseous agents, including CO₂ have replaced them. Gaseous extinguishers should be provided with a suitable applicator for use on engine fires.
- 3) Dry Chemical Powder should be a foam compatible type, capable of dealing with Class B fire (or liquid hydrocarbons).
- 4) Pre-mix foam systems should be fully automatic and be capable of activating instantaneously in the event of an impact of a helicopter on the helideck where fire results. The automatic system should dispense aspirated or non-aspirated foam in a jet or spray pattern.
- 5) The primary media levels specified for a higher intensity operation which is staffed for more than 50% of public transport helicopter movements, assumes a fire attack lasting approximately 5 minutes. It is acceptable, within the overall strategy, to employ at least one additional hand-controlled foam branch pipe for the delivery of aspirated foam, to any part on the landing area or its appendages, with a minimum discharge rate of 225 L/Min.
- 6) Where a Compressed Air Foam System (CAFS) meeting Performance Level B is selected in lieu of standard foam, the capacity and application rate may be accordingly reduced. The minimum requirements for CAFS are shown within the bracketed values in the above table.

Large H2 RFFS Standard Intensity

Extinguishing Agent Requirements

Foam Meeting Performance Level B			Foam Meeting Performance Level C			Complementary Agent	
Total foam solution (Litres)	Minimum discharge rate of foam (L/Min)	Minimum duration (Min)	Total foam solution (Litres)	Minimum discharge rate of foam (L/Min)	Minimum duration (Min)	Dry chemical powder (kg)	Gaseous agent (kg)
1500 (1080)	750 (540)	2 (2)	1050	525	2	45	18

Notes:

- 1) Complementary agents should be capable of discharge at an effective rate delivered from one or two extinguishers.
- 2) Halon extinguishing agents are no longer prescribed for new installations. Gaseous agents, including CO₂ have replaced them. Gaseous extinguishers should be provided with a suitable applicator for use on engine fires.
- 3) Dry Chemical Powder should be a foam compatible type, capable of dealing with Class B fire (or liquid hydrocarbons).
- 4) Pre-mix foam systems should be fully automatic and be capable of activating instantaneously in the event of an impact of a helicopter on the helideck where fire results. The automatic system should dispense aspirated or non-aspirated foam in a jet or spray pattern.
- 5) Where a Compressed Air Foam System (CAFS) meeting Performance Level B is selected in lieu of standard foam, the capacity and application rate may be accordingly reduced. The minimum requirements for CAFS are shown within the bracketed values in the above table.

Large H2 RFFS Low Intensity

Extinguishing Agent Requirements

Foam Meeting Performance Level B			Foam Meeting Performance Level C			Complementary Agent	
Total foam solution (Litres)	Minimum discharge rate of foam (L/Min)	Minimum duration (Min)	Total foam solution (Litres)	Minimum discharge rate of foam (L/Min)	Minimum duration (Min)	Dry chemical powder (kg)	Gaseous agent (kg)
350	175	2	250	125	2	45	18

Notes:

- 1) Complementary agents should be capable of discharge at an effective rate delivered from one or two extinguishers.
- 2) Halon extinguishing agents are no longer prescribed for new installations. Gaseous agents, including CO₂ have replaced them. Gaseous extinguishers should be provided with a suitable applicator for use on engine fires.
- 3) Dry Chemical Powder should be a foam compatible type, capable of dealing with Class B fire (or liquid hydrocarbons).
- 4) Premix-foam units may be aspirated or non-aspirated but should be capable of delivering agent to the seat of the fire.
- 5) Where a Compressed Air Foam System (CAFS) meeting Performance Level B is selected in lieu of standard foam, the capacity and application rate may be accordingly reduced. The minimum requirements for CAFS in this case are assumed to be equivalent to amounts specified for Performance Level C foams.

Large H2 RFFS Higher Intensity

Extinguishing Agent Requirements

Foam Meeting Performance Level B			Foam Meeting Performance Level C			Complementary Agent	
Total foam solution (Litres)	Minimum discharge rate of foam (L/Min)	Minimum duration (Min)	Total foam solution (Litres)	Minimum discharge rate of foam (L/Min)	Minimum duration (Min)	Dry chemical powder (kg)	Gaseous agent (kg)
3750 (2700)	750 (540)	5 (5)	2625	525	5	45	18

Notes:

- 1) Complementary agents should be capable of discharge at an effective rate delivered from one or two extinguishers.
- 2) Halon extinguishing agents are no longer prescribed for new installations. Gaseous agents, including CO₂ have replaced them. Gaseous extinguishers should be provided with a suitable applicator for use on engine fires.
- 3) Dry Chemical Powder should be a foam compatible type, capable of dealing with Class B fire (or liquid hydrocarbons).
- 4) Pre-mix foam systems should be fully automatic and be capable of activating instantaneously in the event of an impact of a helicopter on the helideck where fire results. The automatic system should dispense aspirated or non-aspirated foam in a jet or spray pattern.
- 5) The primary media levels specified for a higher intensity operation which is staffed for more than 50% of public transport helicopter movements, assumes a fire attack lasting approximately 5 minutes. It is acceptable, within the overall strategy, to employ at least one additional hand-controlled foam branch pipe for the delivery of aspirated foam, to any part on the landing area or its appendages, with a minimum discharge rate of 225 L/Min.
- 6) Where a Compressed Air Foam System (CAFS) meeting Performance Level B is selected in lieu of standard foam, the capacity and application rate may be accordingly reduced. The minimum requirements for CAFS are shown within the bracketed values in the above table.

7. Timescales for rectification action

NUIs projects that are classed as 'higher intensity' operations should be assigned the highest priority and any necessary upgrade of RFFS should be completed **within three years from the date of this letter**. For all other operations, with those classed as 'standard intensity' receiving priority over those classed as 'low intensity', rectification should be completed **within six years** with an absolute cut-off for compliance of **30 June 2017**.

8. Request to disseminate to industry asset duty holders

I would be grateful if you could disseminate this letter amongst your members. This letter is copied for information to the offshore helicopter operators, the Helideck Certification Agency and the Health and Safety Executive, Offshore Safety Division.

Yours sincerely,

Kevin P Payne
Flight Standards Officer
Flight Operations Inspectorate (Helicopters)

Appendix 1: Further explanatory guidance and background for definitions and interpretations disseminated in the main letter

1. Elements to be considered for the helicopter transport risk analysis

- 1) The number of planned helicopter movements and frequency of movements.
- 2) The number of passengers landing and taking off from the NUI – whether or not the particular NUI is the final planned outbound or inbound destination for passengers.
- 3) The types of helicopters utilised and specific hazards (e.g. construction, fuel load).

- 4) The characteristics of the helideck and platform general arrangement (e.g. helideck access).
- 5) The largest helicopter authorised to operate to the helideck.
- 6) The level of planned occupation of the NUI including the off-shift policy.
- 7) Whether the helideck is attended or unattended during helicopter movements.

2. Definitions for low, standard and higher intensity operations

Low intensity operations: Low intensity operations are regarded as those installations where the planned number of annual public transport helicopter movements does not exceed 10 and/or where the annual number of passengers landing on and taking off from the installation does not exceed 50. For an installation to qualify as a low intensity operation there should be no planned off-shift stays.

Standard intensity operations: Standard intensity operations are regarded as those where the planned number of annual public transport helicopter movements and/or the annual number of passengers landing on and taking off from the installation exceed the threshold levels prescribed for low intensity operations but where the planned number of movements are not expected to exceed 10 public transport helicopter movements per month and/or the number of passengers landing on and taking off from the installation is not expected to exceed 50 per month. Within this category, helicopters may be used to support regular visits to the installation provided that no off-shift stays are planned.

Higher intensity operations: Higher intensity operations should include any installations where off-shift stays are planned regardless of the frequency or duration of stays. In addition where helicopter operations are engaged to support frequent visits to an installation, but with no planned off-shift stays, these should also be included within the minimum requirements prescribed for higher intensity operations if the number of public transport helicopter movements exceeds 10 per month and/or the number of passengers landing on and taking off from the installation exceeds 50 per month.

Notes:

- 1) A movement is defined as one take-off or one landing. A helicopter landing or taking off with no passengers on board may be regarded as a non-public transport (positioning) flight.
- 2) Installations with planned off-shift stays should automatically consider at least the minimum requirements prescribed for higher intensity operations.
- 3) Passenger numbers should take account of all persons on board the helicopter, excluding aircrew, at the point of touchdown to land or on take-off from the installation.
- 4) With the acceptance of the helicopter operator figures for projected future helicopter movements and passenger numbers may be derived on the basis of data collected for an installation over the previous three year period provided there are no foreseeable changes in operating practices which might result in a significant increase in one or either assessment parameter determining threshold limits.
- 5) The helicopter operator should be consulted on any queries that may arise for an interpretation of frequency of visits.

3. Definitions and interpretations for re-defining Helicopter fire fighting categorisation

ICAO Annex 14 Volume II provides definitions for H1, H2 and H3 as follows:

- **Helicopter Category H1:** A helicopter with an overall length up to but not including 15m.
- **Helicopter Category H2:** A helicopter with an overall length from 15m up to but not including 24m.
- **Helicopter Category H3:** A helicopter with an overall length from 24m up to but not including 35m.

Note: H3 may be discounted on the basis there are no H3 helicopters operating to NUIs on the UKCS.

For the purpose of calculating the critical area for helicopter fire fighting category H1, H2 and H3 for a heliport, the ICAO Heliport Manual applies critical area calculations based on average fuselage dimensions for each category (to form a rectangular area of protection around a generic helicopter). For helicopter operations to NUIs, nearly all the helicopters being operated have fuselage dimensions that are appreciably

greater than the average fuselage dimensions assumed for each generic category. Therefore, to ensure the critical area calculation addresses the fuselage dimensions for a range of helicopters likely to operate to a NUI helideck, critical area assumptions have been determined using the 'worst case' helicopter type within a series of operating helicopters on the following basis:

- **Helicopter Category H1 Large:** includes all Dauphin AS 365 variants.
- **Helicopter Category H2 Medium:** includes all variants of the S76, **AW 139** and the EC 155.
- **Helicopter Category H2 Large:** includes EC 175, AS 332 L1 and L2, EC 225, **S92**, S61 and Bell 214.

For category H2 medium, the [bold] AW 139 is determined to be the worst case helicopter with the largest dimensional combination of fuselage length x width (plus 4m) and for category H2 Large, the [bold] S92 is assumed to be the worst case helicopter. Where NUIs adopt levels in accordance with these helicopter definitions it may be automatically assumed that any other helicopters listed in the same category, or in a lower category (where applicable), are also authorised to use the helideck from the perspective of the adequacy of RFFS. However, no account is taken of further additional types which might be introduced to service NUI operations in the future.

4. Rationale for minimum application rates assumptions

According to ICAO Annex 14 Volume II and the Heliport Manual (Doc. 9261) any foam concentrate used for heliport fire fighting should at least meet ICAO Performance Level B (i.e. Performance Level A foams are not permitted). For Performance Level B foam the standard application rate is 5.5 (L/min)/m² based on the assumed critical area (m²). This is the minimum application rate applied throughout this document for 'standard' Performance Level B foam (e.g. AFFF, FFFP). Advancements in foam technologies mean that the aviation sector is now making increasing use of Compressed Air Foam Systems (CAFS). Due to the superior fire suppression qualities of CAFS, it has been demonstrated through comparative test programmes that where a Performance Level B Compressed Air Foam System is utilised, the minimum application rate of the foam may be reduced

to no less than **4.0 (L/min)/m²**. In addition it is anticipated ICAO Annex 14 Volume I will in future sanction the use of Performance Level C foams for aircraft fire fighting. In a similar way that Performance Level B foam is more efficient than a Level A foam, which is reflected in a lower application rate requirement, so Level C foam is proven to be more effective than a comparative Level B foam. Consequently provision is made in the tables for the use of Performance Level C foam discharged with a minimum application rate of not less than **3.75 (L/min)/m²**. These developments effectively give offshore duty holders much more flexibility to select foam systems based on the performance of each type of foam on the understanding that the more effective the foam technology, the less overall foam solution will be required to achieve the same results. This flexibility is especially useful for platforms where additional topside weight and storage capability are most critical.

Note – ICAO Level C Foam: A new standard for fire fighting foam is currently proposed and proceeding through the International Civil Aviation Organisation (ICAO) to be published in Annex 14 (Volume I) to the Convention on International Civil Aviation. The expected date for applicability of this amendment is 15 November 2012. The standard will require an improvement in fire fighting performance and foam manufacturers will be working to develop foams to meet this new standard. As with any product with an environmental impact, a balance will need to be made between safety, cost and the effects on the environment.

5. Rationale for response time objective and discharge duration requirements

It is proposed that for an installation with RFFS which is unattended for at-least 50% of the time during public transport helicopter movements, a 2-minute minimum discharge capability is permitted. This assumes the automatic application of primary media at the required rate within 15 seconds of an accident occurring with the objective that any fire should be brought “under control” within 1-minute from commencing the discharge of primary foam media, thereby allowing the occupants of the helicopter, during a survivable accident, the opportunity to escape from the helicopter and clear the helideck environs, with the option for abandoning the platform if necessary.

For a platform to be classed as a higher intensity operation there is a good likelihood that the RFFS will be attended for more than 50% of public transport helicopter movements, such that there is a reasonable expectation that trained fire fighters will be present to tackle any fire scenario that might be expected to occur on the helideck including a helicopter crash with fire. In this case, having an additional 3 minutes of media discharge (5 minutes instead of 2 minutes), there is opportunity for a prolonged manual intervention to confront a fire situation and, having controlled the fire with the objective of saving lives, to ensure that the fire is completely extinguished, likely with media in hand to provide further post fire protection. In consideration of these additional objectives, where the discharge duration for the primary extinguishing agent for a higher intensity operation is increased from 2 to 5 minutes, it is acceptable that some of the additional media could be delivered from one or two hand-controlled foam branch pipes to allow delivery of foam to areas which might otherwise be inaccessible to fixed systems – see main letter and section entitled “Methods of foam delivery to the helideck”.

For platforms classed as Low Intensity Operations the provision for an automated means of foam delivery system may be waived providing the Platform Safety Case records and justifies the non-availability of an automated fire-fighting protection system in the event of an accident occurring, which results in a major fire ensuing during a landing or take-off when the platform is unattended. During times when the platform is attended trained fire and rescue crews should have at their disposal appropriate equipment including primary and secondary media for the purpose of saving life (in the event of an accident occurring) and/or for mopping up incidents involving minor fires (e.g. an engine fire). The level of media prescribed is not intended to provide for an extended and sustained attack on a major helicopter incident with fire.

6. Rescue equipment

Rescue equipment should be provided in accordance with CAP 437, Chapter 5, Section 7 and should be provided for all NUI assets regardless of their classification.

7. Personal Protective Equipment (PPE)

All responding RFF personnel should be provided with appropriate PPE to allow them to carry out their duties in an effective manner. Sufficient personnel to operate the RFF equipment effectively, when an installation is attended, should be dressed in suitable protective clothing.

For the selection of appropriate PPE, account should be taken of the HSE Personal Protective Equipment at Work Regulations (PPEWR) and the Provision and Use of Work Equipment Regulations (PUWER) which require equipment to be suitable and safe for intended use, maintained in a safe condition and, where appropriate, inspected to ensure it remains fit for purpose. In addition equipment should only be used by personnel who have received adequate information, instruction and training. PPE should be accompanied by suitable safety measures e.g. protective devices, markings and warnings. A responsible person should be appointed to ensure all PPE is installed, stored, checked and maintained in accordance with manufacturers' instruction.

Appropriate PPE should be determined through a process of risk assessment acceptable to the HCA and the offshore helicopter operators.

Appendix 2: Normally Unattended Installations – list of existing NUI assets on the UKCS by region, requiring a review of Rescue and Fire Fighting

Northern North Sea (10)	UK West Coast (10)	Southern North Sea (96)
Beatrice B	Calder	23E
Beatrice C	DP-3	49-30A (Davy)
Beryl SPM 2	DP-4	Amethyst A1D
Beryl SPM 3	DP-6	Amethyst A2D
BP Unity	DP-8	Amethyst B1D
Erskine	DPPA	Amethyst C1D
Franklin	Hamilton	Anglia A
Goldeneye	Hamilton North	Audrey WD
Jade	Lennox	Audrey XW
Mungo	Millorn West	Babbage

Barque PB	Kilmar	Shell BT
Barque PL	Lancelot	Shell C
Boulton BM	Leman 27B	Shell D
Caister	Leman 27C	Shell E
Carrack QA	Leman 27D	Shell F
Cavendish	Leman 27E	Shell Leman G
Chiswick	Leman 27F	South Valiant
Covette	Leman 27G	Tethys
Europa	Leman 27H	Trent
Excalibur	Leman 27J	Tyne
Galahad	Malory	Vampire
Galleon PG	Markham ST-1	Vanguard QD
Galleon PN	Mirnas	Victor JD
Ganymede	Minerva	Viking AR
Garrow	Munro	Viking CD
Grove	Neptune	Viking DD
Guinevere	North Valiant SP	Viking ED
Hewett 48/29B	Pickerill A	Viking GD
Hewett 48/29C	Pickerill B	Viking HD
Hewett 48/29Q	Ravenspurn North ST2	Viking KD
Hewett 52/5A	Ravenspurn North ST3	Viking LD
Hoton	Ravenspurn RA	Viscount
Hyde	Ravenspurn RB	Vulcan 2 UR
Inde 18A	Ravenspurn RC	Vulcan RD
Inde 18B	Saturn	Waveny
Inde 23C	Schooner	Wenlock
Inde 23D	Sean R	West Sole B
Kelvin	Shell B	West Sole C
Ketch		Windernere

Total No. NUIs = 116

+ 1 Camelot A (subsequently notified)

Appendix E

Additional guidance relating to the provision of meteorological information from offshore installations

Introduction

- E.1 This Appendix provides additional guidance on the provision of meteorological information from offshore installations, which is detailed in Chapter 6.
- E.2 The provision of meteorological information for the safety, efficiency and regulation of international air navigation is subject to international standards and recommended practices described in Annex 3 to the Chicago Convention published by ICAO. Requirements for observer training and observing accuracy are set out by the United Nation's World Meteorological Organization (WMO).
- E.3 [CAP 746 Meteorological Observations at Aerodromes](#) provides the policy and guidance related to the provision of meteorological information at aerodromes in the UK. To ensure compliance with these requirements, and to standardise the provision of meteorological information provided, where practicable CAP 746 applies. Specific exceptions are detailed below.

Contents and standardisation of the weather reports issued by each offshore installation

Wind

- E.4 To be reported as per CAP 746 (Chapter 4).

NOTE 1: The wind speed and direction reported should always be taken directly from the automated information supplied by the anemometer even where these may be sheltered.

NOTE 2: Gusts may be reported in pre-flight weather reports regardless of the difference between mean wind speed and gust speed but should always be reported if they exceed the mean wind speed as specified in CAP 746 (Chapter 4).

Visibility

E.5 To be reported in metres, as per CAP 746 (Chapter 4). The visibility reported is the minimum visibility. Visibilities greater than 10 km should be reported as 9999.

Lightning

E.6 When lightning is observed, it should be included in the report.

Present weather

E.7 Only the following weather phenomena are required to be reported:

Thunderstorm (no precipitation)	Freezing rain
Thunderstorm with rain	Heavy freezing rain
Thunderstorm with rain and snow	Freezing drizzle
Thunderstorm with snow	Heavy freezing drizzle
Thunderstorm with hail	Snow grains
Thunderstorm with heavy rain	Snow
Thunderstorm with heavy rain and snow	Heavy snow
Thunderstorm with heavy snow	Rain and snow
Thunderstorm with heavy hail	Heavy rain and snow
Thunderstorm in the vicinity	Ice pellets
Drizzle	Rain shower
Heavy drizzle	Heavy rain shower
Rain	Rain and snow shower
Heavy rain	Heavy rain and snow shower
Rain and drizzle	Snow shower
Heavy rain and drizzle	Heavy snow shower
	Hail shower

Heavy hail shower	Mist
Shower in the vicinity	Smoke
Fog	Dust
Freezing fog	Sea spray
Fog patches	Squall
Partial fog	Funnel cloud
Shallow fog	Volcanic ash
Fog in the vicinity	Blowing sand
Haze	Sandstorm

NOTE 1: Guidance on the reporting of these present weather phenomena is as per CAP 746 (Chapter 4).

NOTE 2: No coding is required since the report is to be written in plain language.

NOTE 3: If none of the above is observed then the entry for Present Weather will be Nil.

NOTE 4: Where appropriate up to three of the above phenomena may be reported.

Reporting of fog

E.8 If there is fog within a 1000m and the visibility is <1000m in one or more directions then Fog (or Freezing Fog) should be reported as the Present Weather. If there is fog within a 1000m and the visibility is <1000m in only some directions the Fog (or Freezing Fog) should be reported as Present Weather and an annotation should be made in the remarks box denoting the type of fog (i.e. Partial Fog (fog bank) or Fog Patches). Shallow Fog will be presented as the Present Weather if it is observed, whether patchy or as a continuous layer, within 1000m below helideck level (the visibility within the shallow fog will be 1000m or more). Where there is no fog within a 1000m, but fog can be seen within 8km, the Present Weather should be reported as Fog in the vicinity with a note in the remarks section indicating the presence of Shallow Fog, Partial Fog (fog bank) or Fog Patches. Additionally the remarks section could also include a direction in which the fog is seen, e.g. Partial Fog to East.

Cloud

E.9 Cloud amount is reported as:

- Few (FEW);
- Scattered (SCT);
- Broken (BKN); and
- Overcast (OVC);

as per CAP 746 (Chapter 4). Sky Obscured (VV///) and No Significant Cloud (NSC) should also be reported.

E.10 Cumulonimbus (CB) or Towering Cumulus (TCU) should be added to the report when present.

E.11 Cloud heights are to be reported in plain language in feet AMSL, rounded down to the nearest 100 ft. There is no requirement to report cloud above 5,000 ft unless CB or TCU is present.

E.12 A maximum of four cloud groups can be reported.

CAVOK (Cloud and Visibility OK)

E.13 To be reported as per CAP 746 (Chapter 4). When appropriate to do so, CAVOK should be reported as Present Weather.

Air temperature and dew point

E.14 To be reported as per CAP 746 (Chapter 4).

QNH and QFE (atmospheric pressure)

E.15 To be reported as per CAP 746 (Chapter 4).

Significant wave height

E.16 Where sensors are deployed for the measurement of Significant Wave Height the information should be included in the report. The Wave Height should be reported to one decimal place, e.g. 7.6 m.

NOTE: Only wave height information from sensors deployed at the installation concerned should be reported.

Pitch, roll, helideck inclination and significant heave rate

E.17 Current good practice is provided in CAP 437, Chapter 6.

Remarks

E.18 This part of the form can be used to report additional Meteorological-related information that may assist the helicopter crew, e.g. Lightning seen at 12.30, Fog bank to SW, or Heavy Rain shower at 16.20. When a sensor is unavailable and an estimate has been made of the conditions, a note should be recorded in the Remarks section including the original date that the sensor became unserviceable.

Missing or unavailable information

E.19 Exceptionally, when a sensor is unserviceable and the contingency device is not able to be accessed, or is also unserviceable, the report should be annotated with N/A indicating that the information is not available and the original date that the primary sensor became unserviceable should be recorded in the Remarks section.

Example offshore report

E.20 A pre-flight weather report form template is given below that should be used to supply the relevant information. An example report is also provided (see Figure 2).

Figure 1: Offshore weather report form - Template

Location	<input type="text"/>	Vessel Heading	<input type="text"/> degrees
Lat	<input type="text"/> <input type="text"/> <input type="text"/> <input type="text"/>	Long	<input type="text"/> <input type="text"/> <input type="text"/> <input type="text"/>
Date	<input type="text"/>	Time	<input type="text"/> UTC
Wind	<input type="text"/> degrees	Speed	<input type="text"/> knots
		Gust	<input type="text"/> knots
Visibility	<input type="text"/> metres	Lightning Present	<input type="text"/> Yes / No
Present Weather	<input type="text"/>		
Cloud amount	<input type="text"/>	Cloud Height	<input type="text"/> feet
Cloud amount	<input type="text"/>	Cloud Height	<input type="text"/> feet
Cloud amount	<input type="text"/>	Cloud Height	<input type="text"/> feet
Cloud amount	<input type="text"/>	Cloud Height	<input type="text"/> feet
Air Temperature	<input type="text"/> °C	Dew Point	<input type="text"/> °C
Pressure QNH	<input type="text"/> hPa	QFE	<input type="text"/> hPa
Significant Wave Height	<input type="text"/> metres	Significant Heave Rate	<input type="text"/> metres/sec
Pitch	<input type="text"/> degrees up degrees down	Roll	<input type="text"/> degrees left degrees right
		Helideck Inclination	<input type="text"/> degrees
Remarks	<input type="text"/>		

Figure 2: Offshore weather report - Example

Location	METOCEAN1			Vessel Heading	319 degrees				
Lat	N	57	01	56	Long	E	01	57	18
Date	16/04/2012			Time	12:50 UTC				
Wind	230 200V270 degrees			Speed	18 knots		Gust	32 knots	
Visibility	2000 metres			Lightning Present	Yes				
Present Weather	Rain Shower / Thunderstorms in the Vicinity								
Cloud amount	FEW			Cloud Height	800 feet				
Cloud amount	SCT			Cloud Height	1200 feet				
Cloud amount	BKN			Cloud Height	3000 feet				
Cloud amount	BKN CB			Cloud Height	6000 feet				
Air Temperature	18 °C			Dew Point	12 °C				
Pressure QNH	1009 hPa			QFE	1004 hPa				
Significant Wave Height	3.6 metres			Significant Heave Rate	1.1 metres/sec				
Pitch	2.1 degrees up 1.3 degrees down		Roll	1.2 degrees left 1.3 degrees right		Helideck Inclination	2.8 degrees		
Remarks	Hail Shower at 12:30.								

Definition of an offshore meteorological observer

E.21 **Offshore Meteorological Observer:** any competent person who makes a weather observation or who updates a weather observation which is provided either as a Pre-Flight Weather Report or as a Radio Message to a helicopter en route to a fixed or floating offshore facility. Such personnel should be trained and qualified as a Meteorological Observer for Offshore Helicopter Operations.

NOTE 1: Platform operators should allocate sufficient time resources to the meteorological observing staff to enable them to carry out observing duties.

NOTE 2: Meteorological Observers should be located in a position that enables them to assess the weather from an outside observing position, whenever possible, in order to validate that observations are representative of the installation and its vicinity.

E.22 Master Mariners who have been issued with a Marine Coastguard Agency (MCA) Certificate Officer of the Watch (OOW) or equivalent qualification and are regularly providing WMO-compliant ship meteorological observations may be considered competent to provide weather observations for offshore helicopter operations. However, Master Mariners are recommended to become certificated Offshore Met Observers in order to ensure that the information being provided specifically to helicopter operators is to the standards required since there are a number of important differences compared to WMO ship observations.

Applicability of meteorological equipment to helideck categories

E.23 The following categories of helideck should meet the requirements for Meteorological instrumentation given in CAP 437:

- fixed installations (HLL Code A);

- semi-submersible, e.g. semi-submersible crane and lay barges, purpose-built monohull Floating Storage Units (FSUs) and production vessels (HLL Code 1); and
- large ships, e.g. drill ships, Floating Production Storage and Offloading units (FPSOs) whether purpose-built or converted oil tankers, non-semi-submersible and lay barges and self-elevating rigs on the move (HLL Code 1).

NOTE: Due to less frequent helicopter operations, the weather reports for smaller ships, e.g. Diving Support Vessels (DSVs), support and seismic vessels and tankers (HLL Codes 2 and 3), are required to contain only wind, pressure, air temperature and dew point temperature information. For the purposes of this note, 'less frequent helicopter operations' may be interpreted to mean 'not exceeding 12 landings per year'. Similarly, where weather information is being provided by NUIs, the weather report should include (as a minimum) wind, pressure, air temperature and dew point temperature information. Following notification to the Southern Aviation Safety Forum (SASF), only specific NUIs in the southern North Sea are required to provide the information noted above.

Design, siting and back-up requirements for meteorological equipment installed in offshore installations

Wind speed and direction

E.24 See CAP 746, Chapter 7.

Performance

- E.25 The wind measuring equipment should provide an accurate and representative measurement of wind speed and direction.
- E.26 Wind direction data should be oriented with respect to True North.
- E.27 The wind speed measurement should be to an accuracy of within ± 1 kt, or $\pm 10\%$ for wind speeds in excess of 10 kt, of the actual wind speed (whichever is the greater), over the following ranges:

Table 1: Tolerance values of sensors and equipment - Wind speed

Variable	In-tolerance operating range	Recoverable range
Wind speed	0 to 100 kt	0 to 130 kt

- E.28 With wind speeds in excess of 2 kt, the wind direction system should be capable of producing an overall accuracy better than $\pm 10^\circ$. The sensor should be sampled at a minimum rate of four times every second. Where wind systems measure the gust, the equipment should calculate the three-second gust as a rolling average of the wind speed samples.
- E.29 The equipment should be capable of producing two- and ten-minute rolling averages of the wind speed and direction. The algorithms used for the production of such averages should be defined. The average direction displayed should take regard of the numerical discontinuity at North.

Back-up

- E.30 Alternative anemometry meeting the siting requirements specified below and in Chapter 6 should be provided.

NOTE: It is recommended that a hand-held anemometer is used as a back-up in case of the failure or unavailability of the automated sensors; any readings that are taken should be taken from the centre of the helideck. The pilot should be advised that a hand-held anemometer has been used to estimate the wind speed and a remark should be added to the offshore weather report form.

Siting

- E.31 This is detailed in Chapter 6, paragraph 6.13, Assessment of Wind Speed and Direction.
- E.32 The aim is to site the wind sensor in such a position to capture the undisturbed flow. It is recommended that the wind sensor be mounted at the highest practical point, e.g. on the drilling derrick or the telecommunications mast. However, it should be noted that regular servicing is required and for that reason the flare stack should not be used. If no suitable mast is available then a specific wind sensor mast

should be erected; however, this should not interfere with helicopter operations. If the location is obstructed then a second anemometer should be fitted to cover any compass point that may be obstructed from the primary wind sensor. The height AMSL for each anemometer should be recorded. Ultrasonic sensors should not be fitted in close proximity to electromagnetic sources such as radar transmitters.

Temperature

E.33 See CAP 746, Chapter 7.

Performance

E.34 The equipment should be capable of measurement to an accuracy better than $\pm 1.0^{\circ}\text{C}$ for air temperature and dew point, over the following range:

Table 2: Tolerance values of sensors and equipment - Temperature and humidity

Variable	In-tolerance operating range	Recoverable range
Temperature	-25°C to +50°C	-30°C to +70°C
Humidity	5 to 100% Relative Humidity condensing	0 to 100% Relative Humidity condensing

NOTE: Dew point should be displayed for temperatures below zero; frost point should not be displayed.

Temperature and dew point measurements should be measured to a resolution of 0.1°C . Electronic sensors should be sampled at a minimum rate of once per minute.

Back-up

E.35 Alternative sensors should be provided with an accuracy better than $\pm 1.0^{\circ}\text{C}$ for air temperature and dew point measurement. These sensors should be able to be easily read by the observer in the event of a failure of the main sensor.

Siting

- E.36 Temperature and humidity sensors should be exposed in an instrument housing (e.g. Stevenson Screen), which provides protection from atmospheric radiation and water droplets as either precipitation or fog. The sensors should be located in an area that is representative of the air around the landing area and away from exhausts of building heating and equipment cooling systems. For this reason it is recommended that the sensors are located as close to the helideck as possible. The most common area is directly below the helideck, since this provides mechanical protection to the Screen itself. The site should be free of obstructions and away from areas where air may be stagnant, e.g. near blast walls or close to the superstructure of the platform.

Pressure

- E.37 See CAP 746, Chapter 7.

Performance

- E.38 No observing system that determines pressure automatically should be dependent upon a single sensor for pressure measurement. A minimum of two co-located sensors should be used. The pressure sensors should be accurate to within 0.5 hectoPascals of each other.

NOTE: In the event of failure of one or more individual pressure sensors, or where pressure sensors are not accurate to within 0.5 hectoPascals of each other, the system should not provide any pressure reading to the user.

- E.39 Automatic sensors should be sampled at a minimum rate of once per minute in order to detect significant changes.
- E.40 The measurement system should provide a pressure reading to an accuracy of ± 0.5 hectoPascals or better over the following range:

Table 3: Tolerance values of sensors and equipment - Pressure

Variable	In-tolerance operating range	Recoverable range
Pressure	900 to 1050 hPa	850 to 1200 hPa

E.41 The sensor should provide an output with a minimum system resolution of 0.1 hPa.

Back-up

E.42 Suitable back-up instrumentation includes:

- precision aneroid barometers; and
- digital precision pressure indicators.

E.43 Where the pressure is not being determined automatically the observer should ensure that the appropriate height and temperature corrections are applied.

E.44 Manual atmospheric pressure measuring equipment (as noted above) should be checked daily for signs of sensor drift by comparison with other pressure instrumentation located on the offshore installation. CAP 746, Appendix D, Daily Atmospheric Pressure Equipment QNH Check, provides an example of the type of form that may be used to assist in the monitoring process.

Siting

E.45 Pressure readings are of critical importance to aviation safety and operations. Great care should be taken to ensure that pressure sensor siting is suitable and provides accurate data.

E.46 Pressure sensors can accurately measure atmospheric pressure and will provide representative data for the weather report provided the sensors are correctly located and maintained.

E.47 The equipment should be installed so that the sensor measurements are suitable for the operational purpose and free of external influences.

- E.48 If the equipment is not installed at the same level as the notified helideck elevation, it should be given a correction factor in order to produce values with respect to the reference point. For QNH this is the height above sea level and for QFE the height of helideck above sea level.
- E.49 Where required, the manufacturer's recommended venting method should be employed to isolate the sensor from the internal environment. The pressure sensor should be installed in a safe area, typically the Telecommunications Room, and in close proximity to the Meteorological processing system. In most cases, internal venting of the pressure sensors will be satisfactory. However, if it is determined that internal venting may affect the altimeter setting value to the extent that it is no longer within the accuracy limits given below, outside venting should be used. When the pressure sensor is vented to the outside a vent header (water trap) should be used. The venting interface is designed to avoid and dampen pressure variations and oscillations due to 'pumping' or 'breathing' of the pressure sensor venting equipment.
- E.50 The sensors should also be located in an area free of jarring, vibration and rapid temperature fluctuations (i.e. avoid locations exposed to direct sunlight, draughts from open windows, and locations in the direct path of air currents from heating or cooling systems). Regular inspections of the vent header should be carried out to ensure that the header does not become obstructed by dust etc.

Visibility

- E.51 See CAP 746, Chapter 7.

Performance

- E.52 The performance of the measuring system is limited by the range and field of view of the sensor. The equipment should be capable of measurement to the following accuracy limits to a range of 15 km:

Table 4: Performance of the visibility measuring system

Range	Accuracy
Up to and including 550 m	Visibility ± 50 m
Between 600 m and 1,500 m	Visibility $\pm 10\%$
Between 1,5000 m and 15 km	Visibility $\pm 20\%$

E.53 The visibility measuring system should measure to a resolution of 50 m.

E.54 The sensor(s) should be sampled at a minimum rate of once per minute. An averaging period of 10 minutes for weather reports should be used; however, where a marked discontinuity occurs only those values after the discontinuity should be used for obtaining mean values.

NOTE: A marked discontinuity occurs when there is an abrupt and sustained change in visibility, lasting at least two minutes, which reaches or passes through the following ranges:

10 km or more
5,000 m to 9 km
3,000 m to 4,900 m
2,000 m to 2,900 m
1,500 m to 1,900 m
800 m to 1,400 ,
740 m or less

Back-up

E.55 The accredited observer should assess the visibility by eye. Where possible, visibility reference points should be provided. Structures illuminated at night should be indicated. When the visibility has been assessed by eye a remark should be included in the weather report form.

Siting

E.56 The sensor should be positioned in accordance with the manufacturer's specifications and is normally mounted on a mast. The visibility sensor transmits an infrared beam that measures the refraction caused by suspended particles that obstruct visibility, i.e. mist, fog, haze, dust and smoke. For this reason it is important to avoid any interference such as flares, smoke vents, etc. Areas of the installation that are used for wash-down or are susceptible to sea spray should be avoided. The sensor should be located as far away as practicable from other light sources that might affect the measurement, including direct sunlight or spotlights etc., as these will cause interference. These sensors are only suitable for safe areas. These sensors require routine maintenance, calibration and cleaning; hence they should be positioned in a location that is easily accessible.

Present weather sensor

E.57 See CAP 746, Chapter 7.

Performance

E.58 The sensor should be capable of detecting a precipitation rate greater than or equal to 0.05 mm per hour, within 10 minutes of the precipitation commencing.

E.59 Where intensity is measured, the sensor should be capable of measuring the range of intensity from 0.00 mm per hour to 100 mm per hour and resolve this to the following resolutions:

Range	Resolution
0 to 10 mm per hour	0.1 mm
10.5 to 50 mm per hour	0.5 mm
51 to 100 mm per hour	1.0 mm

- E.60 The sensor should be accurate to within $\pm 30\%$ in the range 0.5 to 20 mm per hour.
- E.61 Where the sensor is capable of doing so, it should discriminate between liquid precipitation and frozen precipitation.

Back-up

- E.62 The accredited observer should assess the present weather manually, assisted by reference material as appropriate. When the present weather has been assessed manually a remark should be included in the offshore weather report form.

Siting

- E.63 The sensor should be positioned in accordance with the manufacturer's specifications. The sensor should be located as far away as practicable from the shielding effects of obstacles and structures.

Cloud

- E.64 See CAP 746, Chapter 7.

Performance

- E.65 The performance of the cloud base recorder is limited by the view of the sensor. The equipment should be capable of measurement to the following accuracy limits, from the surface up to 5,000 ft above ground level:

Range	Accuracy
Up to and including 300 ft	Cloud height ± 30 ft
Above 300 ft	Cloud height $\pm 10\%$

- E.66 The cloud base recorder should measure to a resolution of 100 ft.
- E.67 The sensor(s) should be sampled at a minimum rate of once per minute.

- E.68 Where appropriate software is utilised, cloud base detection systems may also provide an indication of the cloud amount. A cloud cover algorithm unit calculates the cloud amounts and the heights of different cloud layers, in order to construct an approximation of the entire sky. Such an approximation is limited by the detection system's coverage of the sky and should not be used in the weather report unless validated by the accredited observer.

Back-up

- E.69 The accredited observer should assess the cloud by eye and estimate the height, assisted by reference material where appropriate. It should be noted that human estimates of cloud height without reference to any form of measuring equipment (particularly at night) may not meet the accuracy requirements stated above, so it is essential that when the cloud height has been assessed manually a remark is included in the offshore weather report form.

Siting

- E.70 The sensor should be positioned in accordance with the manufacturer's specifications and is normally mounted on a platform or pedestal. The sensor should be located as far away as practicable from other light sources or reflections that might affect the measurement. Most ceilometers are fitted with blowers that prevent precipitation from settling on the lens; however, it is recommended that the sensor is installed in an area free of sea spray and away from any areas that are used routinely for wash-down. The sensor should have a clear view of the sky, uninterrupted by cranes or other structures that may obscure the sensor's view. The height of the sensor above sea level should be noted to ensure that the necessary correction is applied to all readings. These types of sensors are only suitable for installation in safe areas and should not be installed near to radars or other radio transmitters.

Calibration, maintenance and servicing periods

- E.71 All primary and back-up sensors should be serviced by an engineer on at least an annual basis. Calibration should take place according to the instrument manufacturer's recommendation. Cleaning and routine maintenance should take place according to the instrument manufacturer's guidance; however, due to the harsh offshore environment, cleaning routines may have to be increased in certain conditions.
- E.72 Unserviceable sensors should be repaired as soon as possible in order to ensure that accurate, timely and complete meteorological observations are provided in support of safe and efficient helicopter operations.

Appendix F

Procedure for authorising offshore helicopter landing areas – letter to offshore helicopter operators, October 2011

Safety Regulation Group
Flight Ops Inspectorate (Helicopters)

October 2011

Dear Sirs

PROCEDURE FOR AUTHORISING OFFSHORE HELICOPTER LANDING AREAS

This letter updates the legal requirements and related industry procedure for the authorisation of offshore helicopter landing areas on installations and vessels for the worldwide use by helicopters registered in the United Kingdom.

Article 96 of the Air Navigation Order (ANO) 2009 requires a public transport helicopter operator to reasonably satisfy himself that every place he intends to take off or land is suitable for purpose.

A UK registered helicopter, therefore, shall not operate to an offshore helicopter landing area unless the operator has satisfied itself that the helicopter landing area is suitable for purpose and that it is properly described in the helicopter operator's Operations Manual.

CAP 437 gives guidance on standards for the arrangements that the CAA expects an operator to have in place in order to discharge this responsibility under article 96. The Helideck Certification Agency (HCA) procedure is established through a memorandum of understanding to withdraw helicopter landing area certification on behalf of the four offshore helicopter operators - Bristow Helicopters Ltd, Bond Offshore, CHC Scotia and British International Helicopters - to enable each to discharge its responsibilities under the ANO.

Article 12 of the ANO 2009 provides that to hold an Air Operator's Certificate (AOC) an operator must satisfy the CAA that amongst other things its equipment, organisation and other arrangements are such that it is able to secure the safe operation of aircraft.

When looking at a particular operator, the CAA will therefore have regard to its 'other arrangements'. These arrangements include the manner in which the operator discharges its duty under article 96, and the CAA for the grant or ongoing assessment of an AOC will audit the helicopter operators' application of the process on which the operator relies. As part of such an audit the CAA will periodically audit the processes and procedures of the HCA, in acting in the role of a sub-contractor to the helicopter operators providing their services to AOC holders for the purpose of authorising offshore helicopter landing areas. As part of such an audit, the CAA will review the HCA procedures and processes and may accompany an operator when the operator undertakes an audit of the HCA procedures or inspects an offshore helicopter landing area.

The legal acceptance for the safety of landing sites rests with the helicopter operator.

Yours faithfully

Captain C Armstrong
Manager Flight Operations Inspectorate (Helicopters)

Appendix G

Guidance for helideck floodlighting systems

Introduction

- G.1 Chapter 4 sets out the best practice requirements for helideck lighting systems consisting of green perimeter lighting, a lit TD/PM Circle and a lit heliport identification 'H' marking. The statement is made within this paragraph that reliance on helideck floodlighting as a provision of primary visual cueing is no longer supported. However, the CAA has no objection to systems conforming to the good practice guidance contained in this Appendix being retained as a back-up for the Circle and 'H' lighting. Where required, floodlights may also be used for lighting the installation name on the helideck.
- G.2 In addition, floodlights may be used for the purpose of providing a source of illumination for on-deck operations, such as refuelling and passenger handling. Any floodlighting provided for on-deck operations should be turned off for the approach, landing and take-off.

General considerations for helideck floodlighting

- G.3 The whole of the landing area should be adequately illuminated if intended for night use. Experience has shown that floodlighting systems, even when properly aligned, can adversely affect the visual cueing environment by reducing the conspicuity of helideck perimeter lights during the approach, and by causing glare and loss of pilots' night vision during the hover and landing. Furthermore, floodlighting systems often fail to provide adequate illumination of the centre of the landing area leading to the so called 'black-hole effect'. It is essential, therefore, that any floodlighting arrangements take full account of these problems. Further good practice guidance on suitable arrangements is provided (below) in

paragraph 3 'Improved Floodlighting System', extracted from a further interim guidance letter issued by the CAA on 9 March 2006 and updated for this Appendix.

- G.4 Although the modified floodlighting schemes described will provide useful illumination of the landing area without significantly affecting the conspicuity of the perimeter lighting and will minimise glare, trials have demonstrated that neither they nor any other floodlighting system is capable of providing the quality of visual cueing available by illuminating the TD/PM and 'H' (see Chapter 4, paragraph 4.22). These modified floodlighting solutions should therefore be regarded as **temporary arrangements only**. It is essential that any such floodlighting systems are considered in collaboration with the helicopter operator who may wish to fly a non-revenue approach to a helideck at night before confirming the acceptability of the scheme.
- G.5 The floodlighting should be arranged so as not to dazzle the pilot and, if elevated and located off the landing area clear of the LOS, the system should not present an obstacle to helicopters landing and taking off from the helideck. All floodlights should be capable of being switched on and off at the pilot's request. Setting up of lights should be undertaken with care to ensure that the issues of adequate illumination and glare are properly addressed and regularly checked. For some decks it may be beneficial to improve depth perception by floodlighting the main structure or 'legs' of the platform.

NOTE: It is important to confine the helideck lighting to the landing area, since any light overspill may cause reflections from the sea. The floodlighting controls should be accessible to, and controlled by, the HLO or Radio Operator.

Improved floodlighting system

A modified extract from the CAA's letter to industry dated 9 March 2006

- G.6 For helidecks located on platforms with a sufficiently high level of illumination from cultural lighting, the need for an improved floodlighting system may be reviewed with the helicopter operator(s), i.e. in such circumstances it may be sufficient just to delete or disable the existing deck level floodlighting. This concession assumes that the level of illumination from cultural lighting is also sufficiently high to facilitate deck operations such as movement of passengers and refuelling (where applicable). It is a condition that, prior to the removal of floodlights, extended trials of the 'no-floodlight' configuration are conducted and their subsequent removal will be subject to satisfactory reports from air crews to indicate the acceptability of operating to the helideck with the re-configured lighting.
- G.7 In the absence of sufficient cultural lighting, the CAA recommends that installation owners consider a deck level floodlighting system consisting of four deck-level xenon floodlights (or alternative lights having the same photometric specification) equally spaced around the perimeter of the helideck. In considering this solution, installation owners should ensure that the deck-level xenon units do not present a source of glare or loss of pilots' night vision on the helideck, and do not affect the ability of the pilots to determine the location of the helideck on the installation. It is therefore essential that all lights are maintained in correct alignment. It is also desirable to position the lights such that no light is pointing directly away from the prevailing wind. Floodlights located on the upwind (for the prevailing wind direction) side of the deck should ideally be mounted so that the centreline of the floodlight beam is at an angle of 45° to the reciprocal of the prevailing wind direction. This will minimise any glare or disruption to the pattern formed by the green perimeter lights for the

majority of approaches. An example of an acceptable floodlighting arrangement is shown at Figure 1.

NOTE: For some larger helidecks it may be necessary to consider fitting more than four deck-level xenon floodlights (or alternative lights having the same photometric specification), but this should be carefully considered in conjunction with the helicopter operator giving due regard to the issues of glare and loss of definition of the helideck perimeter before further deck-level units are procured. The CAA does not recommend more than six units even on the largest helidecks. The height of any floodlighting when installed around the helideck should not exceed 25 cm above deck level or (for a helideck where the D-value is 16.00 m or less) be more than 5 cm above deck level.

Figure 3: Typical floodlighting arrangement

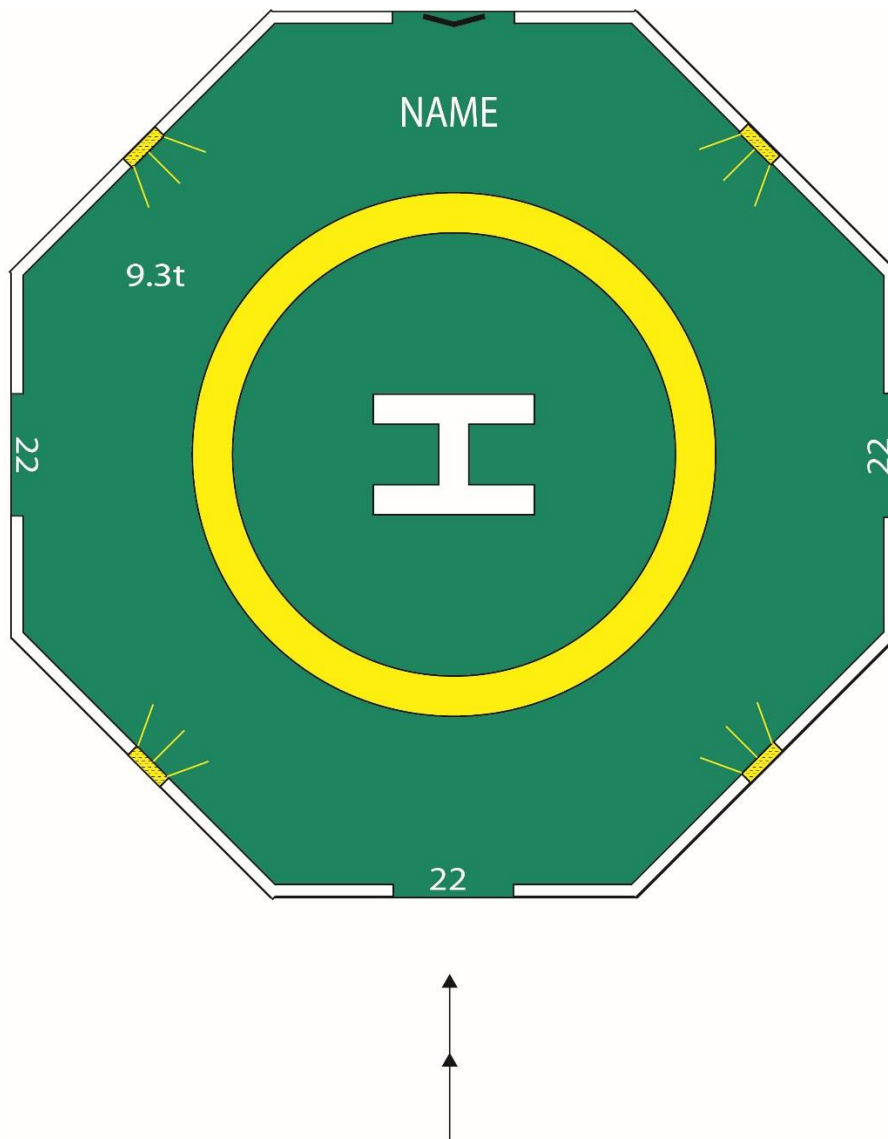

Appendix H

Risk assessment for helicopter operations to helidecks in the UKCS which are sub-1D

H.1 The following table should form the basis of an aeronautical study (risk assessment) conducted by, or on behalf of, an offshore helicopter operator when intending to service helidecks using helicopters with an overall length (D) greater than the design D of the helideck (referred to in this document as a sub-1D operation). The assumption is made that sub-1D operations will only be considered in the following circumstances and/or conditions:

- 1) Applicable only for multi-engine helicopters operating to performance class 1 or class 1 equivalent, or to performance class 2 when taking into account drop down and deck edge miss during the take-off and landing phase.
- 2) For a helideck that provides a load bearing surface (represented by the Touchdown and lift-off area - the TLOF) of between 0.83D and 1D, it should be ensured that a minimum 1D circle (representing the Final approach and take-off area – the FATO) is assured for the containment of the helicopter. From the periphery of the FATO (not the TLOF) the LOS extends; the non load-bearing area between the TLOF perimeter and the FATO perimeter should be entirely free of 'non-permitted' obstacles while ensuring that any objects essential for the operation located on or around the TLOF (load bearing) perimeter should not exceed the revised obstruction height criteria set out in paragraph 5 below.
- 3) This assessment may be considered for any helideck on a fixed offshore installation whether a PMI or NUI. An installation or vessel that is subject to dynamic motions exceeding HCA stable deck criteria in pitch, roll and heave, should not be considered for alleviation from the CAP 437 1D Standard.

- 4) This assessment when applied to helidecks completed on or before 1 January 2012, may take advantage of an ICAO alleviation permitting the outboard edge of the (approximately) 1.5m helideck perimeter netting to extend above the level of the landing area by no more than 25 cm (i.e. no structural modification of deck edge netting supports is mandated by Annex 14 where the 25 cm height limitation is not exceeded for older installations). However, for installations completed on or after 1 January 2012 it is expected that the 4th Edition Annex 14 Volume II Standard (3.3.15) be met - this requires that the height of the helideck safety net be no greater than the adjacent helideck load-bearing surface.
- 5) For helidecks that are minimum size (0.83D), ICAO Annex 14 Volume II prescribes the height limit for permitted objects around the edge of the TLOF, and in the 1st segment of the LOS, to be 5 cm. For helidecks which are $\geq 1D$ (and also have a D-value $>16.00m$) a 25 cm limitation is currently applied. This risk assessment is content to permit for existing helidecks with a TLOF between the 0.83D minimum and the 1D (standard) a rising scale for the treatment of essential objects around of the TLOF perimeter and for the 1st segment of the LOS. "Essential objects" permitted around the edge of the TLOF are notified in CAP 437, Chapter 3, paragraph 3.23 and include helideck guttering and raised kerb, helideck lighting, foam monitors (or ring-main system) where provided and, helideck perimeter netting for helidecks completed on or before 1 January 2012. For sub-1D operations the following limits may apply between the TLOF and FATO boundary and in the LOS 1st segment: For a TLOF: $>0.83D = 5$ cm ADL, $>0.92D = 15$ cm ADL, $1D > =$ not more than 25 cm ADL. For helidecks completed after 14 November 2013 where the TLOF is 16.00m or less all essential objects around the TLOF should be limited to 5 cm. Figure 1 illustrates a 0.83D minimum size TLOF. The inner circle bounded by the octagonal-shaped helideck represents the sub-1D TLOF (in the illustration a 0.83D load bearing surface). The outer circle illustrates the 1D FATO

which provides containment of the helicopter and from which is derived the origin of the LOS. The chevron denoting the origin should be physically marked at the periphery of the FATO. The diameter of the TLOF is the declared D, marked at the chevron.

- 6) Operations to sub-1D fixed helidecks should not be considered below 0.83D. Operations to moving helidecks should not be considered below 1D.
- 7) The size of the landing area should not be less than minimum dimensions prescribed in the approved Rotorcraft Flight Manual Supplement.

Table 5: Non-compliance with ICAO standards/considerations/mitigations to account for compromise

1	<p>Potential for a reduction in the distance from helideck (TLOF) centre to the limited obstacle sector (LOS) (denoting the origin of the 1st and 2nd segments).</p> <p>Annex 14 Volume II (4th Edition), Section 4.2.16 and Figure 4-9</p>	<p>It is essential that clearance from obstacles in the LOS is maintained; for this reason, the sub-1D load bearing (landing) surface (the TLOF) should be surrounded by a 1D circle (the FATO) that is (with the exception of permitted objects) free of any obstacles. This will reflect the obstacle clearances provided for a 1D helideck (but see also the provision of 6a). To ensure that obstacle clearances are maintained for the helicopter, the touchdown and positioning marking circle should be 0.5 of the notional 1D FATO (not of the landing surface (the TLOF)), and located at the centre of the TLOF; and never offset (Annex 14, Volume II, 5.2.10.4 and CAP 437 Glossary of Terms for TD/PM circle refer). E.g.: For an AW 139 (a D=16.63m helicopter) operating to a 16.00m diameter load bearing TLOF, the inner diameter of the TD/PM circle, located on helideck (TLOF) centre, should be $16.63 \times 0.5 = 8.315\text{m}$. The FATO minimum diameter should be 16.63m.</p>
2	<p>Reduction in suitable and sufficient visual references required for the pilot during all flight phases.</p>	<p>Adequate visual cues provided for aircrew are essential for the conduct of safe operations to helidecks. On a sub-1D helideck it is likely these will to some extent be compromised. An aeronautical study should ensure that visual cues, within their field of view are adequate for aircrew to perform the following visual tasks:</p>

	ICAO Heliport Manual, Chapter 5	<ul style="list-style-type: none"> ▪ Identification of helideck location early on in the approach ▪ Visual cues to help maintain the sight picture during approach ▪ Visual cues on final approach to hover position ▪ Visual cues for landing ▪ Visual references on lift-off and hover <p>It is important that the helideck visual cues (in the form of effective markings and lighting) are in accordance with CAP 437, Chapter 4 and that markings and deck mounted lighting remain uncontaminated at all times (e.g. deposits of guano on the surface of a helideck may compromise markings and/or deck-mounted lighting). A wind sock should be provided to facilitate an accurate indication of wind direction and strength over the helideck. For night operations lighting systems should include effective obstruction lighting in addition to helideck lighting (consisting of perimeter lights and "H" and circle lighting) and an illuminated windsock.</p>
3	<p>Reduction in the space available for passengers and crew to safely alight and embark the helicopter and to transit to and from the operating area safely.</p> <p>ICAO Heliport Manual, Section 2.3.1.3</p>	<p>The reduction in available load-bearing surface (area) means that clearances between passengers/crew moving around the helideck and the rotor systems of the helicopter are reduced. It is essential that this is fully considered on a helicopter type specific basis. It should be ensured that sufficient access points are available to avoid the situation of passengers and crew having to pass close to helicopter 'no-go' areas (e.g. in relation to main and tail rotor systems). Where, to avoid these issues, personnel are required to transit close to the deck edge, an operating (wind) limit may need to be considered to assure the safe movement of passengers. Additional lighting may be required to ensure safe movements are maintained at night.</p>
4	Reduction in the space available for securing helicopters,	<p>The surface area available should be able to comfortably accommodate a sufficient tie-down pattern arrangement to allow the most critical helicopter(s) to be tied-down (as</p>

	<p>for the conduct of safe and efficient refuelling operations (where provided) and for post-crash teams to provide effective fire and rescue intervention in the event of an incident or accident occurring.</p> <p>ICAO Heliport Manual, Section 2.3.1.3 and Section 6.8.1</p>	<p>required). Where refuelling operations are conducted the space available around the helicopter should allow this to occur safely and efficiently at all times. Sufficient access points should be provided to allow fire and rescue teams to move to the scene of a helideck incident or accident from an upwind location and to allow passengers to escape downwind to safety.</p>
5	<p>Elements of the helicopter will be over permitted obstacles at the edge of the load bearing landing surface.</p> <p>ICAO Annex 14 Volume II, Section 3.3.4, 3.3.12 and 3.3.13</p>	<p>Commencing at the 3rd Edition of Annex 14 Volume II, the permitted height for essential objects located around the TLOF in the 210° obstacle free sector and in the 1st segment of the 150° limited obstacle sector reduced from 25 cm (10') for a 1D helideck to 5 cm (2') for a TLOF which is less than 1D and/or 16.00m or less. For new builds this is regarded as adequate mitigation for the reduction in the dimension of the load bearing area to address the presence of objects which because of their function are required to be located immediately around the TLOF. For existing installations where a TLOF is provided which is larger than the minimum (0.83D), but $\leq 1D$, the maximum height of essential objects around the perimeter may be relaxed [on an ascending scale] in accordance with H.1 Condition 5.</p>
6	<p>Reduction in the margin built-in to allow for touchdown/positioning inaccuracies during landing.</p>	<p>It should be assumed that even amongst experienced, well trained aircrew there will inevitably be some degree of variability in the actual point of touchdown within the landing area. The touchdown/positioning marking circle provides an effective visual reference to guide the handling pilot to the point of touchdown (See CAP 437 Glossary of Terms, including Note, for the TD/PM circle) but scatter has potential</p>

	ICAO Annex 14 Volume II, Section 5.2.10.1 and 5.2.10.2	to occur, particularly where external factors beyond a pilot's control come into play. This may include the influences of prevailing meteorological conditions at the time of landing (e.g. wind, precipitation etc.), and/or any helideck environmental effects encountered (e.g. turbulence, thermal effects). There is also the unplanned incidence of a sudden partial power loss (an engine malfunction) to consider at a critical stage of the approach to land or take-off. Chapter 3 of CAP 437 addresses environmental effects in detail and where these cannot be fully 'designed out', it may be necessary to apply operating restrictions to ensure flights only occur in acceptable conditions. To mitigate for touchdown /positioning inaccuracies in challenging Meteorological conditions it may be necessary to impose additional restrictions e.g. limits applied for a combination of wind speed and direction. It is essential that a good visual means of assessing wind strength and direction is always provided for the pilot by day and by night. Markings should be kept free of contamination which may reduce a pilot's ability to touchdown accurately. The TD/PM circle and "H" should be lit for night operations.
7	Reduction in 'helpful ground cushion' effect from rotor downwash. Annex 14 Volume II, Section 3.3.9	It is a condition of Annex 14 Volume II, Section 3.3.9 that the TLOF shall provide ground effect. The reduction in the load bearing area (TLOF) for sub-1D operations means that the beneficial effect of ground cushion will likely suffer some reduction. The reduction in helpful ground cushion needs to be considered for each helicopter on a case-by-case basis, particularly when operating to a sub-1D helideck with a perforated surface i.e. some modern helideck designs incorporate a passive fire-retarding feature which allows unburned fuel to drain away through specially manufactured holes consisting in a drain-hole pattern over the surface of the load bearing area.

Glossary of terms and abbreviations	
FATO	Final approach and take-off area – A defined area over which the final phase of an approach manoeuvre to hover or landing is completed and from which the take-off manoeuvre is commenced.
TLOF	Touchdown and lift-off area – A dynamic load bearing area on which a helicopter may touchdown and lift-off.
FATO/TLOF	For helidecks of $\geq 1D$, the FATO and TLOF are always coincidental and therefore occupy the same space and have the same load bearing characteristics. For helidecks which are $< 1D$, but no less than $0.83D$, it is the TLOF only that is permitted to reduce, the FATO remains as $1D$. In this case the TLOF and the FATO are assumed to be collocated.
Essential objects permitted	Includes, but may not be limited to a) around the TLOF: perimeter and floodlights, guttering and raised kerb, foam monitors or ring main system, handrails and associated signage, status lights, b) on the TLOF: helideck net and helideck touchdown marking (“H” and “circle”) lighting, c) in the area between the TLOF perimeter and the FATO perimeter, helideck safety netting is present (for installations completed on or before 1 January 2012 this is permitted to exceed above the TLOF surface. For helidecks completed after 1 January 2012 the outboard edge of netting should be flush level with the load bearing [landing] area).

Figure 1: Obstacle limitation surface and sectors for a 0.83D TLOF

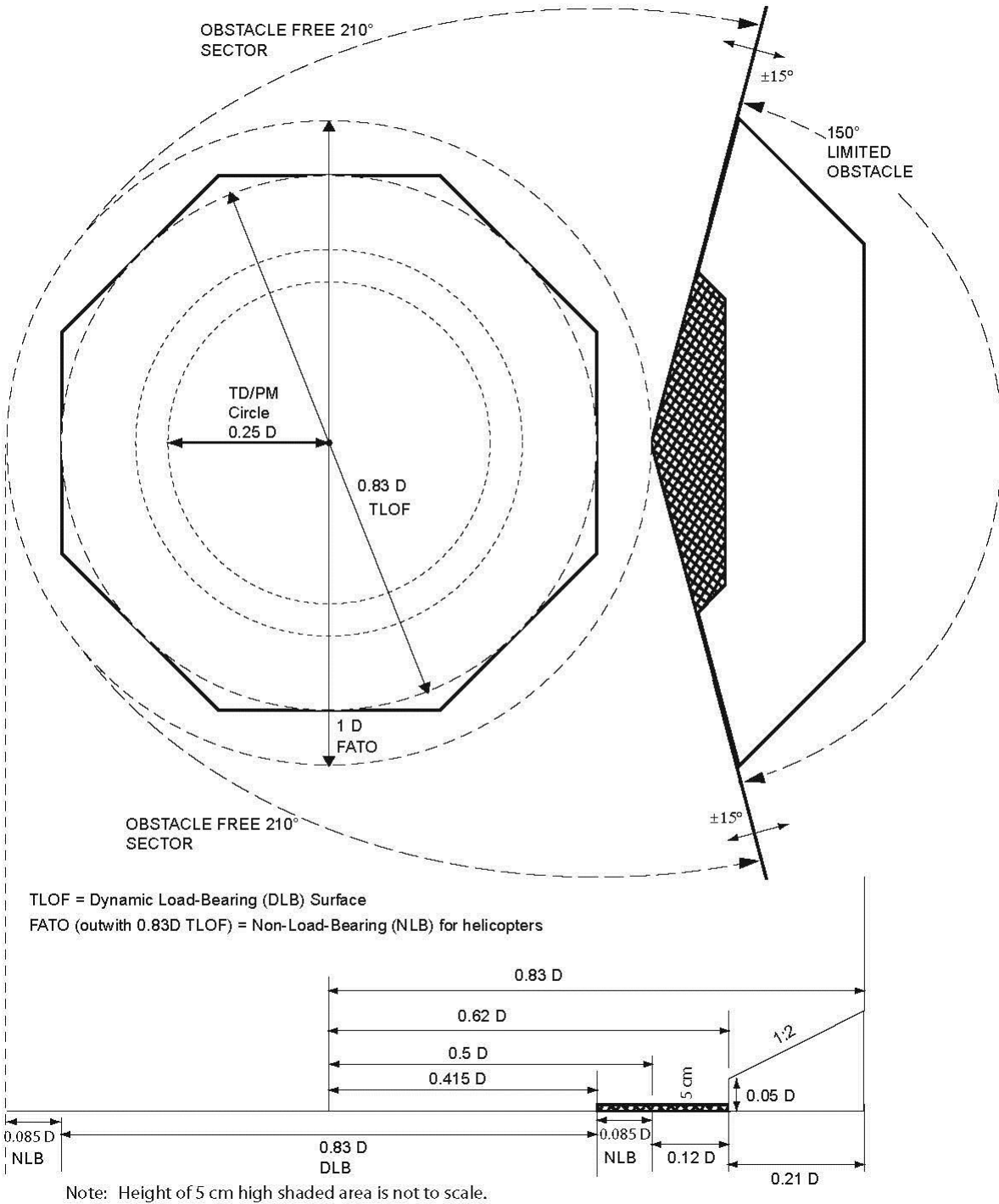

Appendix I

CAA protocol for operations against operating status lights or black decks

Platform:

Name of offshore installation manager responsible:

.....

Dispensation is requested to permit a Helicopter landing on subject platform's helideck, with NUI status lights flashing/non-functional. A Duty-Holder's case-specific risk assessment is attached to this dispensation request. Please provide as much information as possible in column B.

Platform status is detailed below. Key permissive criteria are detailed on Page 2.

Installation status details

Helideck status		
Column A		Column B
1	Are or have the NUI status lights been activated?	
2	Are NUI status lights disabled or de-powered?	
3	Are NUI status lights reset and remain functional?	
4	Are helideck perimeter/circle lights functional?	
5	Are helideck floodlights functional?	
6	Does the helideck have automated fire-fighting?	

7	Is the automated fire-fighting system functional?	
8	Is there anything else the pilot/operator should be made aware of?	
Installation status		
9	Are comms live and showing installation status?	
10	Is the installation in ESD status/has the system taken executive action?	
11	Is the platform running under a normal power supply?	
12	Is the platform running under a UPS?	
13	Have you been able to confirm the well and pipeline valves confirmed shut?	
14	Does the installation have automatic venting/blowdown?	
15	Have you been able to confirm the blowdown valve(s) (if fitted) have opened?	
16	If so, have the topsides been vented and confirmed diminished to an expected and safe level?	
17	Is power generation or back-up power online?	
18	Is the detected event 'Gas', 'Fire' or 'Other'?	
19	What was the initiating event?	
Gas detection causal event (delete if not applicable)		
20	Is detection of a confirmed or unconfirmed nature?	

21	If confirmed – how many points have activated?	
22	How many zones have seen detection?	
23	Have any detectors activated since initial event?	
24	Does the F&G system remain functional?	
25	Is detected event within an enclosed module?	
26	When do you expect the F&G system to go offline?	
Fire detection causal event (delete if not applicable)		
27	Is detection of a confirmed or unconfirmed nature?	
28	If confirmed – how many points have activated?	
29	How many zones have seen detection?	
30	Have any detectors activated since initial event?	
31	Does the F&G system remain functional?	
32	Is detected event within an enclosed module?	
33	Is detected event heat, smoke or flame?	
34	When do you expect the F&G system to go offline?	

Visual status (from standby vessel)	
35	Has a standby vessel carried out a close inspection?
36	Are there any signs of noise, smoke, fire or gas?
37	Is there any sign of hydrocarbon spillage to sea?
38	Were any other anomalies/impediments noted?

Key permissive criteria	
<p>If the answer to any of these questions is other than 'Yes' further consultation between Duty-Holder and Helicopter Operator is required. This may result in more in-depth risk assessment, further data gathering and/or a further period of status monitoring to establish and confirm safe landing conditions. In such cases the Helicopter Operator should contact FOI(H).</p>	
	Yes/No
1	Does a <i>communications/telemetry</i> system remain functional or was telemetry available for a suitable period, showing the plant status and fire and gas/ESD system status?
2	Has the installation reacted in accordance with the approved design <i>cause and effects</i> matrix?
3	Do <i>pressures</i> and (where applicable) levels remain constant across the process plant, and at the expected in design and safe levels?
4a*	If the installation has an <i>auto-vent/blowdown capability</i> – which should have been activated – has this been confirmed as complete wither by vent valve position indication and vent duration, or topsides pressure indication?
4b*	If the installation has a <i>manual vent capability</i> is the residual pressure within design limits and stable?

5	Can you confirm that the activated detection is limited to a single <i>F&G zone</i> ?	
6	Can you confirm that <i>no other detectors</i> on the installation have been activated since the initial event?	

* Either 4a or 4b.

As Offshore Installation Manager for the subject platform, I confirm that the information detailed above is true and correct.

	Name	Signed	Date	Time
OIM for platform				
Field OIM				
For helicopter operator				

Operations, if deemed safe, are subject to the following:

- Flight by day under VFR conditions only
- Only essential personnel shall be carried
- No bus stopping
- Platform has MEL entry re status light
- Operator to log incidents and provide returns to HCA and CAA

Appendix J

Specification for a helicopter hoist status light

Application

- J.1 With reference to paragraph 10.30 in Chapter 10 of CAP 437 – Standards for Offshore Helicopter Landing Areas, wind turbine platforms are required to be provided with a means of indicating that the blades and nacelle are safely secured prior to commencing helicopter hoist operations.
- J.2 A single green light is recommended for this purpose which is capable of displaying both a steady and flashing green signal. A steady green signal is displayed to indicate to the pilot that the turbine blades and nacelle are secure and it is safe to operate. A flashing green signal is displayed to indicate that the turbine is in a state of preparation to accept hoist operations or, when displayed during hoist operations, that parameters are moving out of limits. When the light is extinguished this indicates that it is not safe to conduct helicopter hoist operations.

Operational requirements

Location

- J.3 The light should be located on the winching area platform of the wind turbine such that it remains within the field of view of the pilot during the approach to the wind turbine and throughout the winching operation, i.e. the coverage should be 360 deg. in azimuth. (The preferred location of the light is on top of the Safety Zone railing as shown in CAP 437, Chapter 10 and in Figure 3 below).

NOTE: Obscuration of the light when installed due to the wind turbine blades may be ignored.

Performance

- J.4 The light should be conspicuous at a range of at least 500m and detectable at a range of at least 700m in a meteorological visibility of 3km in daylight ($E_t = 10^{-3.5}$) and, if required, at night ($E_t = 10^{-6.1}$).
- J.5 The light should not present a source of glare or dazzle the pilot. The critical case in this respect is when the helicopter is closest to the light during the winching operation itself; at this point the lowest elevation of the helicopter relative to the light is assumed to be 15 degrees, i.e. at least 3m above the light and laterally displaced by no more than 10m. Note that lights with small apertures (e.g. lights using LED sources) will result in higher luminance and will be more likely to cause glare; care should be taken in designing the light to avoid excessive luminance.

Day/Night operation

- J.6 Winching operations are presently conducted in daylight (VMC) conditions, but may be permitted to take place at night in the future. Light intensities for both day time and night operations are therefore specified. In the event that night time operations are being conducted, the light unit intensity should be controlled by a photocell as operation of the light at the daylight setting at night is very likely to dazzle the pilot. This photocell needs to be shielded from direct sunlight in order to correctly measure ambient light, particularly during sunset and sunrise when the sun is low in the sky.
- J.7 The light should transition from the daylight setting to the night time setting when the ambient illuminance falls below 500 lux and should switch before it reaches 50 lux. The light should transition from the night time setting to the daylight setting when the ambient illuminance rises above 50 lux and before it reaches 500 lux. The transition from one setting to another should be accomplished smoothly (linear transition to within $\pm 10\%$) without any noticeable step changes.

Characteristics

J.8 The following characteristics should apply for both steady burning and flashing modes of the helicopter hoist status light. All intensities should be measured in accordance with the test procedures for helideck status lights contained in Appendix B of CAA Paper 2008/01. The modified-Allard method (see Appendix C of CAA Paper 2008/01) should be used for calculation of the effective intensity.

- The effective intensity as a function of elevation should be as detailed in Table 1 and illustrated in Figures 1 and 2.
- The effective intensity specified in Table 1 should apply to all angles of azimuth.
- The colour of the helicopter hoist status light should be green as defined in ICAO Annex 14 Vol.1 Appendix 1, para. 2.1.1(c), whose chromaticity lies within the following boundaries:
 - Yellow boundary $x = 0.360 - 0.080y$
 - White boundary $x = 0.650y$
 - Blue boundary $y = 0.390 - 0.171x$
- In flashing mode, the light should flash at a rate of 120 flashes per minute (2 Hz), $\pm 10\%$. The maximum duty cycle should be no greater than 50%.
- The system should be designed so that it fails safe, i.e. any failure in the helicopter hoist status light system should result in the light being extinguished.
- The system and its constituent components should comply with all regulations relevant to the installation.
- The light should be tested by an independent test house. The optical department of the test house should be accredited to ISO/IEC 17025.

Table 1: Vertical beam characteristics for helicopter hoist status light

	Min. intensity		Max. intensity	
	2° to 10°	>10° to 90°	0° to 15°	>15° to 90°
Day	410cd	16cd	750cd	120cd
Night	16cd	3cd	60cd	60cd

Figure 1: Vertical beam characteristics for helicopter hoist status light for day time operations

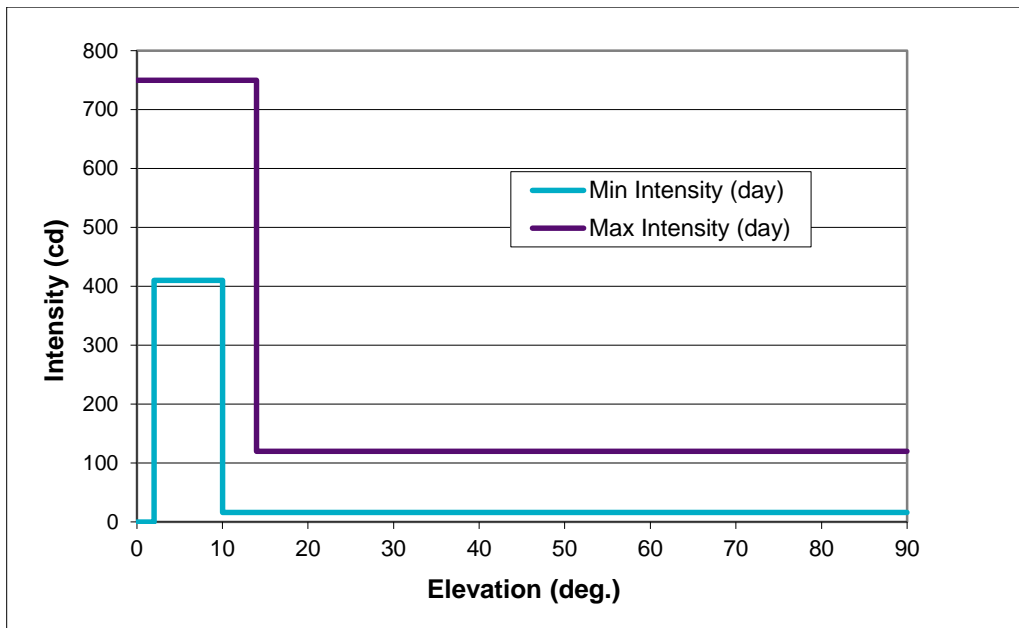

Figure 2: Vertical beam characteristics for helicopter hoist status light for night time operations

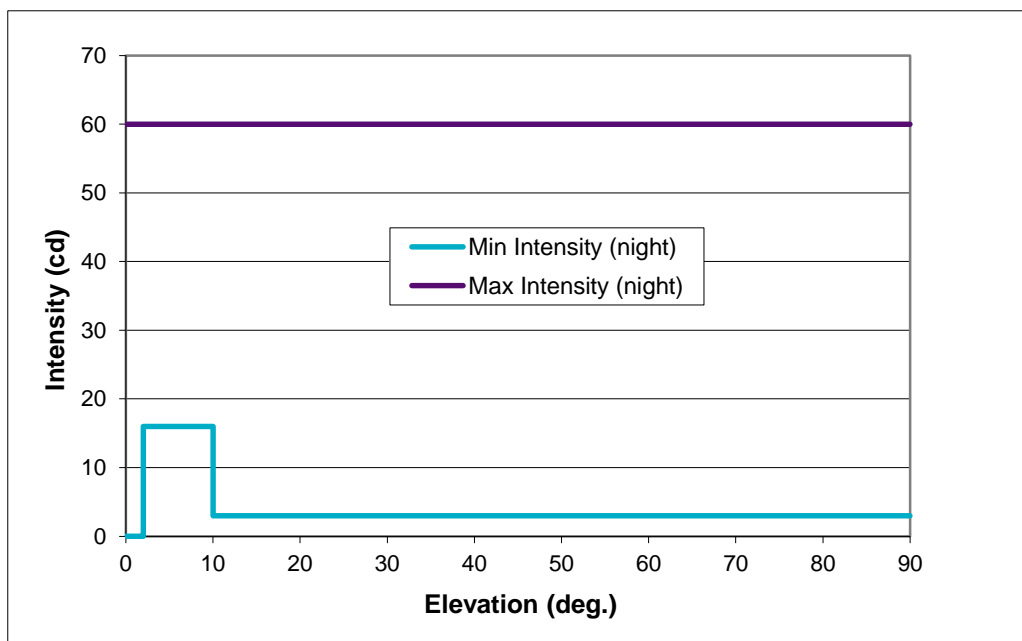
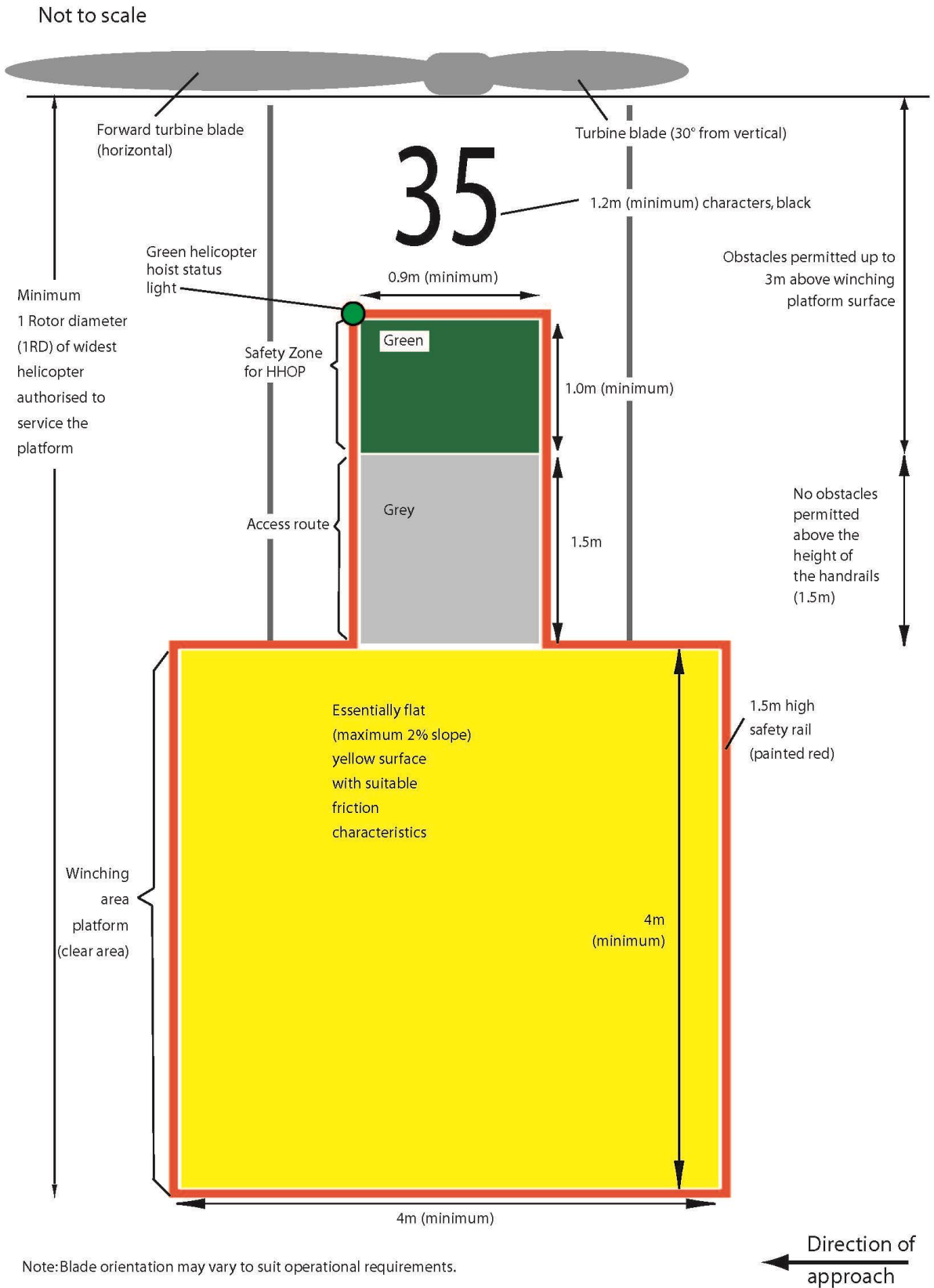

Figure 3: Preferred location of the helicopter hoist status light (located on top of the safety railing)



Appendix K

Helideck friction survey protocol

Introduction

K.1 The protocol contained in this document represents a test method acceptable to the CAA for the conduct of helideck friction surveys in compliance with paragraph 3.39 of Chapter 3 of CAP 437, 8th edition, Standards for Offshore Helicopter Landing Areas.

Friction measuring equipment

K.2 The exercise of measuring helideck friction involves a number of factors, all of which have to be taken into consideration:

- The limiting friction values cited in CAP 437 are related to the threshold at which a helicopter would be expected to slide on a helideck. The test method should therefore result in friction values that are representative of the 'real' situation of a helicopter on a helideck. For example, this suggests the use of a wheeled tester employing a tyre made of the same material as helicopter tyres.
- Within certain limits, a helicopter could land almost anywhere on a helideck and an adequate level of friction should exist wherever the helicopter wheels touchdown. This favours devices employing a continuous measurement technique and surveys that cover the entire surface of the helideck.
- Human error and the influence of commercial pressure commonly arise as factors in accidents, hence a measurement method that is less reliant on human input would be expected to deliver greater integrity. Devices that provide automatic electronic data collection, storage and analysis are therefore to be preferred. In addition, this also favours devices employing a continuous measurement

technique and surveys that cover the entire surface of the helideck which, together, reduce the opportunity for missing 'poor' areas of a deck during testing.

- K.3 In view of the above, the CAA considers that continuous friction measuring equipment (CFME) testers providing automated data collection, storage and processing facilities should be used for measuring helideck friction. They enable the key variable of surface wetness to be consistently controlled, measure the surface friction in a representative manner, and enable the entire helideck area to easily be surveyed in a reasonable time.
- K.4 Accordingly, the following protocol is applicable only to the use of CFME.

Survey procedure

General

- Deck needs to be dry.
- Resolution of 1m² minimum.

Preparation

- Calibration of tester iaw manufacturer's instructions.
- Remove landing net if fitted.
- Inspect sit for debris etc., rectify as required.
- Mark out site ready for survey.

Survey

- Entire landing area to be covered by parallel runs at no greater than 1m centres, repeated with orthogonal runs as shown below.

Figure 1: Helideck friction survey procedure using CFME testers

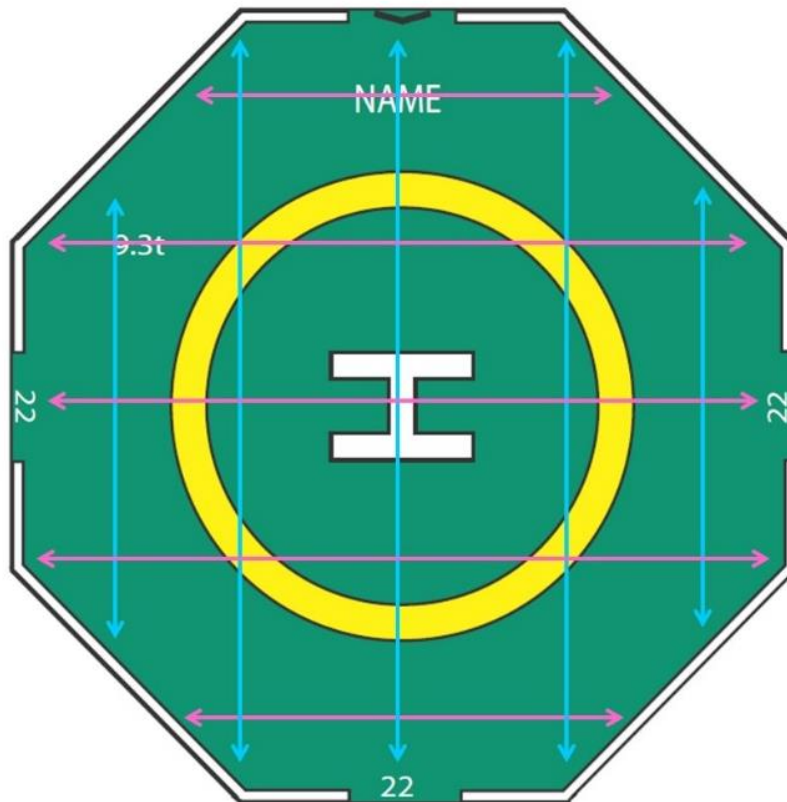

Presentation of results

- For entire landing area, a matrix of readings for each 1 m square.
- Average values for:
 - area inside TD/PM circle,
 - area outside TD/PM circle,
 - paint markings (where TD/PM circle and H lighting not installed).